



CPT67

Commercial Series Pizza Prep Table



CPT67
12/19/17
Item # 13315

W x D x H
67" x 32.25" x 43.5"*
*with 6" casters

CPT67



Dimensions / Capacity

	Two Section CPT67
Interior Storage Capacity (CF) (AHAM)	19.9ft ³
Overall Width x Depth	67" x 32.25"
Height (including 6" casters)	43.5"
Depth with Cutting Board Installed (including 1" bumper)	36"
Door Opening Width x Height	22.5" x 23"
Depth with Door Fully Open (including 1" bumper)	57.75"
Adjustable Shelves	4
Shelf Dimensions (W x D)	24.75" x 25.5"
Pan Capacity (# of 1/3rd size x 4" deep)	9
Maximum Pan Depth	6"
Crated Weight	420 lbs.
Crated Width x Depth x Height	69" x 34" x 44"

Electrical / Refrigeration

	Two Section CPT67
Voltage	115/60/1
HACR Breaker	15.0 Amps
Electrical Connection (NEMA)	5-15P Ⓢ
Voltage Range	104-126
Ambient Temp. Range	45° to 100°F
Control Setpoint Range	14° to 45°F
Amperage	5.5
Energy Consumption (kWh/day) @NSF	5.0
Heat Rejection (BTU/Hr.) @NSF	706
Approx. Nominal Compres. BTU/HR (HP)	2607(1/3HP)
Refrigerant / Charge Amount (oz)	R-134a (8.8 oz)

Options

- 6" Legs
- Additional epoxy shelves
- Divider bars

Warranty

* 3 Year - parts and Labor on entire machine.
5 Year - Parts on Compressor
Valid in United States, Canada, Puerto Rico and U.S. Territories. Contact factory for warranty in other countries.

Item #: _____

Project: _____

Qty: _____

AIA#: _____

Features

- ▶ Engineered to maintain NSF-7 temperatures in 100°F ambient. (Certified to NSF-7 temperatures in 86°F ambient.)
- ▶ Rail utilizes an adjustable ducted air distribution system to distribute air evenly and maintain product temperature
- ▶ Stainless steel interior
- Stainless steel exterior front, sides and top
- Solid state digital controller with temperature alarms and LED display (Fahrenheit or Celsius)
- Exclusive "stepped" door design to protect door gasket
- Spring assisted self-closing doors with stay open feature
- Extruded aluminum flush mount door handle
- Field reversible doors
- Front breathing air flow design
- Provided with a full complement of polycarbonate plastic 1/3rd size pans, 4" deep and adapter bars
- 67" x 19" x 1/2" thick white polyethylene cutting board is standard
- Evaporator coils are epoxy electrocoated (E-Coat) to help fight corrosion
- One epoxy coated shelf per section is standard
- Anodized aluminum shelf supports adjustable in 1/2" increments
- Standard with 6" casters (two with brakes)
- Three year parts and labor warranty
- Five year compressor warranty
- 8 ft. cord and plug



CPT67

Commercial Series Pizza Prep Table



CPT67
12/19/17
Item # 13315

FRONT VIEW

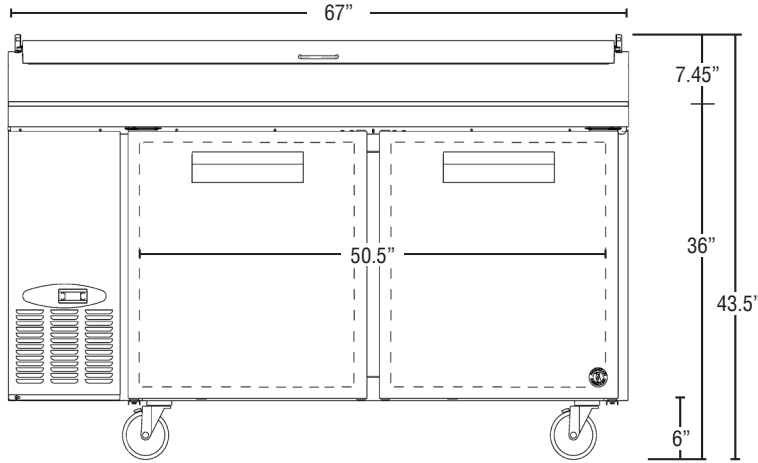

CPT67

SIDE VIEW

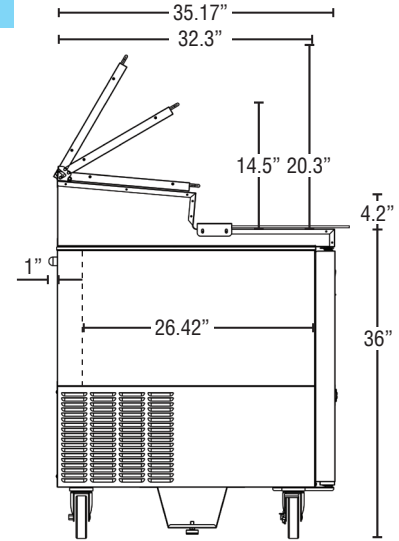

CPT67

PLAN VIEW

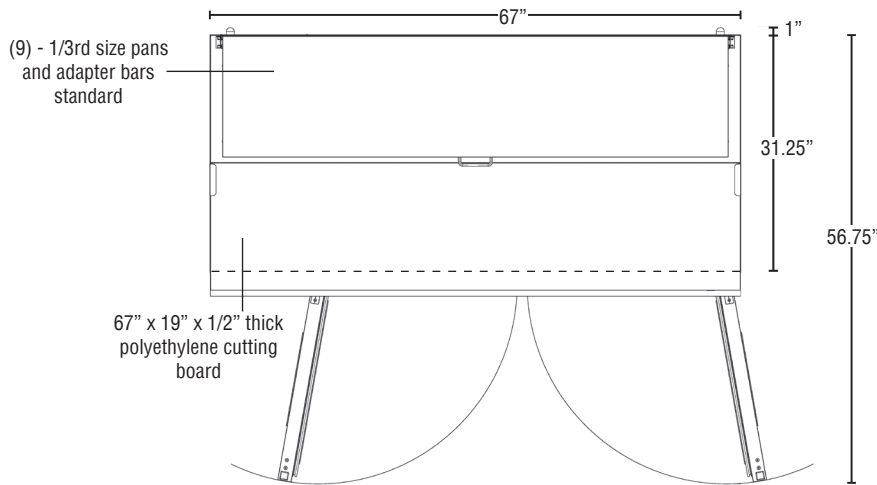

CPT67

Cabinet Construction

The exterior cabinet top, front, and sides, are constructed of high quality stainless steel. The exterior back and bottom are constructed of coated steel. The cabinet interior back and sides are stainless steel with an ABS ceiling and stainless steel floor. One heavy duty epoxy coated shelf per section is standard. Mounted on anodized aluminum pilasters the shelves are adjustable in 1/2" increments. Cabinet walls and doors are insulated with 2" of foamed in place polyurethane. 6" polyolefin stem casters (two with brakes) are standard. The raised refrigerated rail is constructed of stainless steel interior and exterior (except back is galvanized steel). The rail is air cooled and utilizes a unique ducted air distribution system to distribute air evenly and maintain product temperature at safe levels. The rail will accommodate 1/6th, 1/3rd, 1/2 and full size pans 6" deep. Pans are located 1.5" below the front of the rail to assist in access to food product. An insulated, stainless steel, one piece hinged, lid is standard. Pizza preparation table is supplied with a 67" x 19" x 1/2" thick N.S.F. approved white polyethylene cutting board.

Door Construction

Door is constructed of high grade stainless steel exterior with an ABS interior liner. Hoshizaki's exclusive "stepped" design protects the recessed gasket while product is removed from the cabinet. Door is provided with a one piece, extruded aluminum, flush mount handle. Spring assisted self-closing door is equipped with a stay open feature past 90 degrees. Snap-in magnetic door gaskets are durable and easily removed for cleaning. Field reversible door hinging is standard.

Refrigeration System

Front breathing refrigeration system allows unit to be built in to any enclosure with zero clearance at the side or rear. The high efficiency refrigeration system is self-contained with an epoxy electrocoated (E-Coat) evaporator coil for extended life. Condensate removal is accomplished with an energy efficient non-electric evaporation system. A capillary tube controls the flow of environmentally friendly R-134A refrigerant through the evaporator. Refrigeration system utilizes a heated defrost element to eliminate any ice on the evaporator coil. An innovative ducted air distribution system distributes air evenly around food product in the rail. Engineered to maintain NSF-7 temperatures in 100°F ambient. (Certified to NSF-7 temperatures in 86°F ambient.) Pizza preparation tables are supplied with a full complement of N.S.F. approved polycarbonate plastic, 1/3rd size pans, 4" deep and stainless steel adapter bars. 115 volt units are equipped with an eight foot cord and NEMA rated plug (20.0 amps or less).

Printed in the U.S.A.