



CPT93-D6

Commercial Series Pizza Prep Table with Drawers



CPT93-D6
04/07/17
Item # 13361

W x D x H
93" x 32.25" x 43.5"*
*with 6" casters

CPT93-D6



Dimensions / Capacity

	Three Section CPT93-D6
Interior Storage Capacity (CF) (AHAM)	30.1ft ³
Overall Width x Depth	93" x 32.25"
Height (including 6" casters)	43.5"
Depth with Cutting Board Installed	36"
Door Opening Width x Height	22.5" x 23"
Depth with Drawer Fully Open (including 1" bumper)	57.5"
Pan Capacity (# of 1/3rd size x 4" deep)	12
Maximum Pan Depth	6"
Crated Weight	625 lbs.
Crated Width x Depth x Height	95" x 33.75" x 44.25"

Electrical / Refrigeration

	Three Section CPT93-D6
Voltage	115/60/1
HACR Breaker	15.0 Amps
Electrical Connection (NEMA)	5-15P (Ⓢ)
Voltage Range	104-126
Ambient Temp. Range	45° to 100°F
Control Setpoint Range	14° to 45°F
Amperage	5.5
Energy Consumption (kWh/day) @NSF	5.7
Heat Rejection (BTU/Hr.) @NSF	803.5
Approx. Nominal Compress. BTU/HR (HP)	2607(1/3HP)
Refrigerant / Charge Amount (oz)	R-134a (8.8 oz)

Options

- Rail adapter bars
- Divider bars

Warranty

- * 3 Year - parts and Labor on entire machine.
 - 5 Year - Parts on Compressor
- Valid in United States, Canada, Puerto Rico and U.S. Territories. Contact factory for warranty in other countries.

Item #: _____

Project: _____

Qty: _____

AIA#: _____

Features

- ▶ Engineered to maintain NSF-7 temperatures in 100°F ambient. (Certified to NSF-7 temperatures in 86°F ambient.)
- ▶ Rail utilizes an adjustable ducted air distribution system to distribute air evenly and maintain product temperature
- ▶ Stainless steel interior
- Stainless steel exterior front, sides and top
- Solid state digital controller with temperature alarms and LED display (Fahrenheit or Celsius)
- Cabinet and drawers are insulated with 2" of CFC free, foamed in place polyurethane
- Drawer slides are constructed of 14 gauge stainless steel with acetal rollers
- Drawer frames are constructed of 14 gauge stainless steel and securely fastened to cabinet
- Drawers have a 250 lb. dynamic load rating
- Drawers will accommodate (2) 12" x 20" x 6" deep pans (pans by others)
- Provided with a full complement of polycarbonate plastic 1/3rd size pans, 4" deep and adapter bars
- Front breating air flow design
- Extruded aluminum flush mount drawer handle
- Magnetic drawer gasket is easily removable for cleaning
- 93" x 19" x 1/2" thick white polyethylene cutting board is standard
- Evaporator coils are epoxy electrocoated (E-Coat) to help fight corrosion
- Standard with 6" casters (two with brakes)
- Three year parts and labor warranty
- Five year compressor warranty
- 8 ft. cord and plug



CPT93-D6

Commercial Series Pizza Prep Table with Drawers



CPT93-D6
04/07/17
Item # 13361

FRONT VIEW

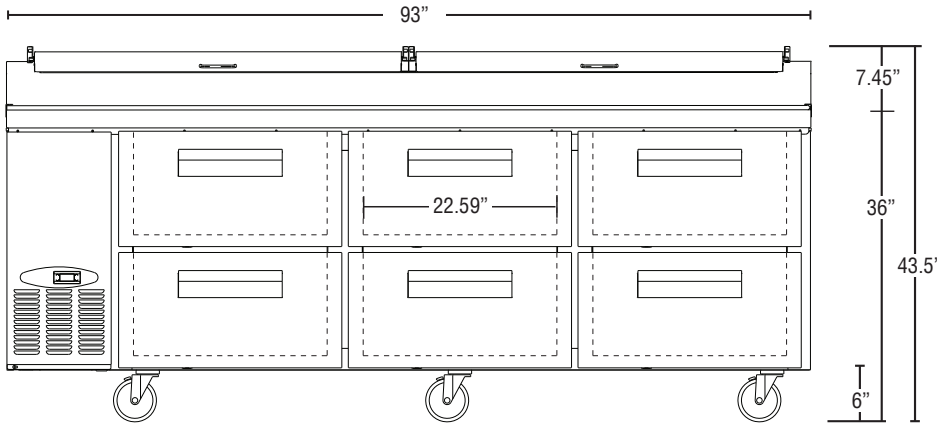

CPT93-D6

SIDE VIEW

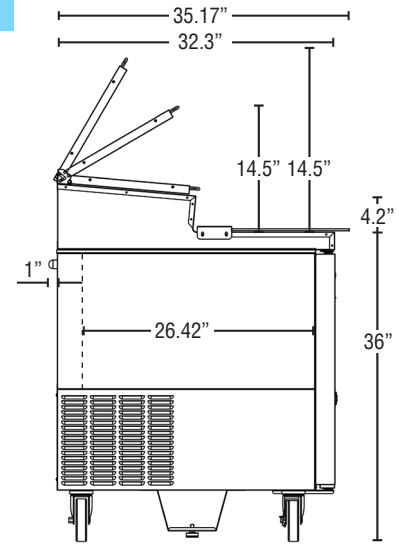

CPT93-D6

PLAN VIEW

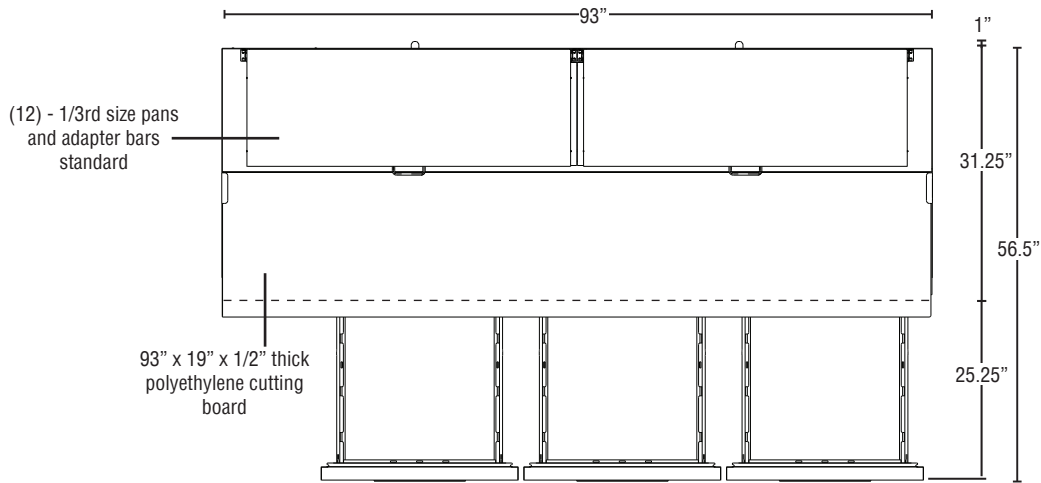

CPT93-D6

Cabinet Construction

The exterior cabinet top, front, and sides, are constructed of high quality stainless steel. The exterior back and bottom are constructed of coated steel. The cabinet interior back and sides are stainless steel with an ABS ceiling and stainless steel floor. Cabinet walls and drawers are insulated with 2" of environmentally friendly, CFC free, foamed in place polyurethane. 6" polyolefin stem casters (three with brakes) are standard. The raised rail is constructed of stainless steel interior and exterior (except back is galvanized steel). The rail is air cooled and utilizes a unique patent pending ducted air distribution system to distribute air evenly and maintain product temperature at safe levels. The rail will accommodate 1/6th, 1/3, 1/2 and full size pans 6" deep. Pans are located 1.5" below the front of the rail to assist in access to food product. Two insulated stainless steel hinged lids are standard. Pizza preparation table is supplied with a 93" x 19" x 1/2" thick N.S.F. approved polyethylene cutting board.

Drawer Construction

Drawer fronts are constructed of high grade stainless steel with stainless steel interior and are insulated with R-134a CFC free, foamed in place polyurethane. Each drawer accommodates (2) 12" x 20" x 6" deep pans (pans by others). Drawer frames are formed of 14 gauge stainless steel all welded construction and securely fastened in the cabinet. The drawer slides are constructed of heavy duty 14 gauge stainless steel and durable acetal rollers with stainless steel ball bearings to prevent metal to metal contact. The drawer slides have a dynamic load capacity of 250 lbs. and have been life tested (fully loaded) three hundred thousand cycles without showing significant wear. The flush mount handles are constructed of extruded aluminum. Snap-in magnetic drawer gaskets are durable and easily removed for cleaning.

Refrigeration System

Front breathing refrigeration system allows unit to be built into any enclosure with zero clearance at the side or rear. The high efficiency refrigeration system is self-contained with an epoxy electrocoated (E-Coat) evaporator coil for extended life. Condensate removal is accomplished with an energy efficient non-electric evaporation system. A capillary tube controls the flow of environmentally friendly R-134a refrigerant through the evaporator. Refrigeration system utilizes a heated defrost to eliminate any ice on the evaporator coil. An innovative patent pending ducted air distribution system distributes air evenly around food product in the rail. Engineered to maintain NSF-7 temperatures in 100°F ambient. (Certified to NSF-7 temperatures in 86°F ambient.) Pizza preparation tables are supplied with a full complement of N.S.F. approved plastic 1/3 size pans 4" deep and stainless steel adapter bars. 115 volt units are equipped with an eight foot cord and plug (20.0 amps or less).

Printed in the U.S.A.