



CR3S-FGE

Commercial Series Glass Door Refrigerators



CR3S-FGE
04/03/17
Item # 13392

Item #: _____
 Project: _____
 Qty: _____
 AIA#: _____

W x D x H
83" x 34.75" x 79.75"*
*4" casters

CR3S-FGE



Dimensions / Capacity

Three Section CR3S-FGE

Interior Storage Capacity (CF)	74.3 ft ³
Interior Storage Capacity (CF) (AHAM)	68.1 ft ³ Total; 47.2 ft ³ (Left) 20.9 ft ³ (Right)
Overall Width x Depth	83" x 34.75"
Height (including 4" casters)	79.75"
Door Opening Width x Height	22 x 59.5"
Depth with Door Open at 90°	57.25"
Adjustable Shelves	9 Total; (6 Left) (3 Right)
Shelf Dimensions (W x D)	24 x 24.75"(Left) 21.25" x 26" (Right)
Crated Shipping Weight	895 lbs
Crated Width x Depth x Height	86" x 36.5" x 83"

Electrical / Refrigeration

Three Section CR3S-FGE

Voltage	115/60/1
HACR Breaker	20.0 Amps
Electrical Connection (NEMA)	5-20P
Voltage Range	104-126
Ambient Temp. Range	45° to 100°F
Control Setpoint Range	31° to 52°F
Amperage	12
Energy Consumption (kWh/day) @ASHRAE	4.85 (Left) 2.56 (Right)
Heat Rejection (BTU/Hr.) @NSF	928 (Left) 570 (Right)
Approx. Nominal Compres. BTU/HR (HP)	2373 (1/4HP) (Left) 1625 (1/5HP) (Right)
Refrigerant / Charge Amount (oz)	R-134a/(13.7 oz)(Left) R-134a/(11oz)(Right)

Options

Warranty

- Door reversal kit
- Air filter
- Additional epoxy shelves
- Wire tray pan slides
- Stainless steel shelves
- (HS-5092, HS-5093)

* 3 Year - parts and Labor on entire machine.
 5 Year - Parts on Compressor
 Valid in United States, Canada, Puerto Rico and U.S. Territories. Contact factory for warranty in other countries.

Features

- ▶ **Energy efficient vertical LED lights provide up to 8 times brighter light**
- ▶ **Stainless steel interior with stainless steel exterior front and sides**
- ▶ **Unique "ducted" air distribution system**
 - Refrigerant flow is controlled with a thermostatic expansion valve (TXV)
 - Solid state digital controller with temperature alarms and LED display (Fahrenheit or Celsius)
 - Cabinet is insulated with 2-3/8" of CFC free, foamed in place polyurethane
 - Glass doors are energy efficient Multi Pane, Argon filled with locks
 - Spring assisted self-closing doors with stay open feature
 - Sturdy 8 gauge stainless steel hinge plate with welded hinge pin
 - One piece, full length, chrome handle
 - Field reversible doors (with optional kit)
 - Evaporator coils are epoxy electrocoated (E-Coat) to help fight corrosion
 - Energy efficient automatic hot gas condensate evaporator
 - Stainless steel shelf supports
 - (3) epoxy coated wire shelves per section are standard
 - Standard with 4" casters (two with brakes)
 - Stackable (two units high) to conserve warehouse floor space
 - Three years parts and labor warranty
 - Five year compressor warranty
 - 8 ft. cord and plug
 - Meets DOE 2017 requirements for energy conservation



CR3S-FGE

Commercial Series Glass Door Refrigerators



CR3S-FGE
04/03/17
Item # 13392

FRONT VIEW

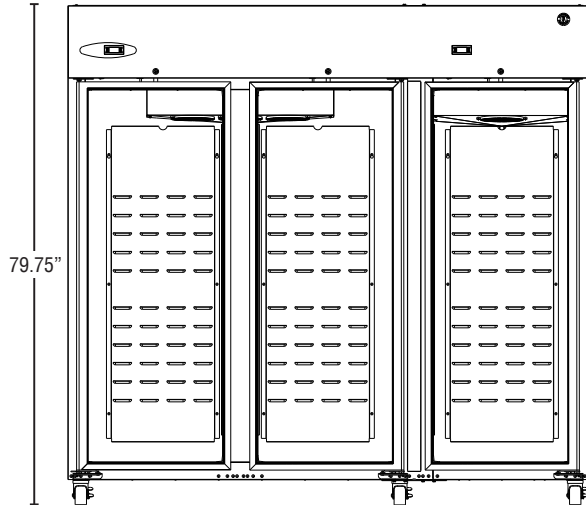

CR3S-FGE

SIDE VIEW

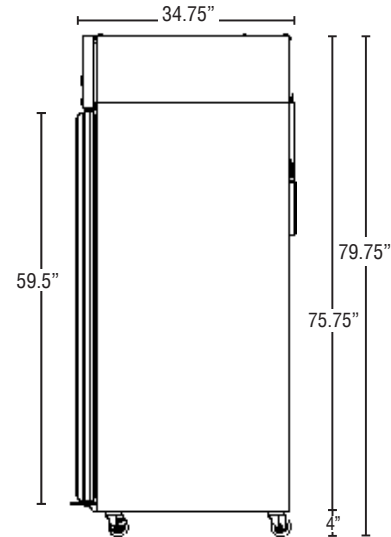

CR3S-FGE

PLAN VIEW

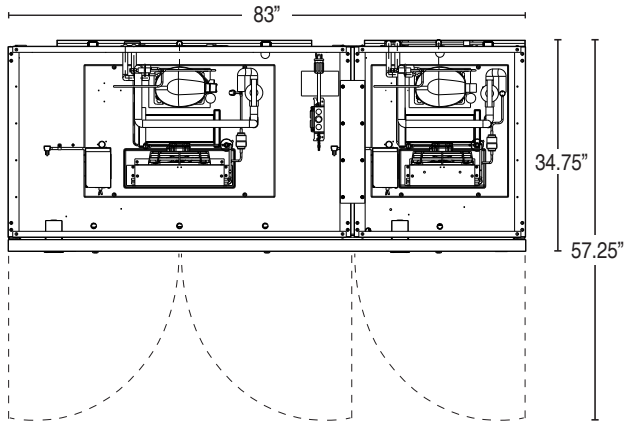

CR3S-FGE
(Showing Door Swings)

Cabinet Construction

The exterior cabinet front, and sides, are constructed of high quality stainless steel. The exterior top, back, and bottom are constructed of coated steel. The cabinet interior is constructed of stainless steel with a unique "ducted" air flow system. Three (3) heavy duty epoxy coated shelves per section are standard. Mounted on stainless steel pilasters shelves are adjustable in 1" increments. Cabinet walls and doors are insulated with 2-3/8" of environmentally friendly, CFC free, foamed in place polyurethane. Five LED light strips mounted vertically provide up to 8 times brighter light than fluorescent bulbs and last up to 42,500 hours longer. 4" factory installed polyolefin casters (two with brakes) are standard.

Door Construction

Glass doors are constructed of high grade silver anodized aluminum with a full length chrome handle. Door glass is energy efficient multi pane, argon filled with locks. The door hinges are all metal and include an adjustable torsion spring closure that will not wear out like traditional cam-lift hinges. Hinge plates are constructed of heavy duty stainless steel. Doors stay open at 90° and are self-closing at 75°. Snap-in magnetic door gaskets are durable and easily removed for cleaning. Door hinging is field reversible (with an optional door reversal hinge kit).

Refrigeration System

The high efficiency refrigeration system is self-contained with an epoxy electrocoated (E-Coat) evaporator for extended life. Top mounted refrigeration system is easily accessible for service. The refrigeration system components are assembled on a high density expanded polypropylene platform that is removable from the main unit. A unique ducted air flow system achieves uniform air distribution within the cabinet to eliminate hot spots. Condensate removal is accomplished with an energy efficient non-electric evaporation system. A thermostatic expansion valve (TXV) controls the flow of environmentally friendly R-134a refrigerant through the evaporator. Solid state digital controls monitor the operation and performance of the refrigeration system. The controls also provide visual high and low temperature and high and low voltage alarms. A LED display shows the cabinet temperature and is adjustable to Fahrenheit or Celsius. 115 volt units are equipped with an eight foot cord and plug (20.0 amps or less).

Printed in the U.S.A.