



CRMR27(-8 / -12M)

Commercial Series Sandwich Top and Mega Top Refrigerators

CRMR27(-8 / -12M)
12/14
Item #13297



Hoshizaki America, Inc. reserves the right to change specifications without notice.



Item #

Project:

Qty:

*AutoCad available on KCL

CRMR Dimensions W x D x H

I Section - 27" x 30" x 45.2"*

*with 6" casters

Electrical/Refrigeration

Voltage 115/60/1

HACR Breaker

I Section - 15.0

Electrical Connection (NEMA)

I Section - 5-15P

Voltage Range 104-126

Ambient Temp. Range 45° to 86°F

Temperature Range 32° to 52°F

*Refrigerant R-134a

Warranty

Valid in United States, Canada, Puerto Rico, and U.S. Territories. Contact factory for warranty in other countries.

- **Three Year** - Parts & Labor on entire machine.
- **Five Year** - Parts on: Compressor.

Options

- 2" Casters
- 4" Casters
- 6" Legs
- Additional epoxy shelves
- Flat lift off stainless steel cover
- Stainless steel back
- Large pan adapter bars



Intertek Intertek

- Stainless steel exterior front, sides and top
- Anodized Aluminum interior sides and back with stainless steel interior floor
- Stainless steel exterior door with ABS interior liner
- Cabinet and doors are insulated with 2" of CFC free, foamed in place polyurethane
- Exclusive "stepped" door design to protect door gasket
- Spring assisted self-closing doors with stay open feature
- Extruded aluminum flush mount door handle
- Field reversible doors
- Magnetic door gasket is easily removable for cleaning
- Front breathing air flow design
- Innovative air distribution system distributes air evenly to maintain product temperature
- Provided with a full complement of polycarbonate plastic 1/6th size pans, 4" deep
- 27"x10"x1/2" thick white polyethylene cutting board is standard
- Enamel coated evaporator coil
- One epoxy coated wire shelf is standard
- Anodized aluminum shelf supports adjustable in 1/2" increments
- Standard with 6" casters (two with brakes)
- Three years parts and labor warranty
- Five year compressor warranty
- 8 ft. cord and plug

Dimensions / Capacity

Model #	One Section CRMR27-8	One Section CRMR27-12M
Interior Storage Capacity (CF)	7.2 ft ³	
Overall Width x Depth	27" x 30"	
Height (including 6" casters)	45.2"	
Depth with Cutting Board Installed	30.7"	37.3"
Door Opening Width x Height	22.6" x 22.9"	
Depth with Door open at 90°	54.5"	
Adjustable Shelves	1	
Shelf Dimensions (W x D)	22.0" x 16.0"	
Pan Capacity (# of 1/6 size x 4" deep)	8	12
Maximum Pan Depth	6"	
Crated Shipping Weight	185 lbs	
Crated Height x Width x Depth	45.1" x 31.5" x 34"	

Electrical / Refrigeration Data

Model #	One Section CRMR27-8	One Section CRMR27-12M
Amperage	2.6	
Energy Consumption (kwh/day) NSF	3.8	
Heat Rejection (BTU/Hr.) @NSF	540	
Approx. Nominal Compres. BTU/HR(HP)	1029(1/6HP)	



© HOSHIZAKI AMERICA, INC.

618 Hwy. 74 S., Peachtree City, GA 30269
TEL 800-438-6087
FAX 800-345-1325
www.hoshizaki.com



CRMR27(-8 / -12M)

Commercial Series Sandwich Top and Mega Top Refrigerators

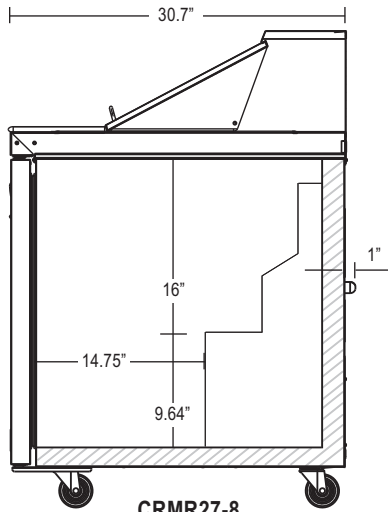

**CRMR27-8
SIDE
(Cross Section)**

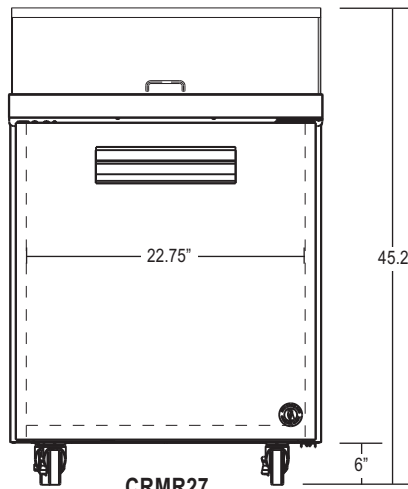

**CRMR27
FRONT**

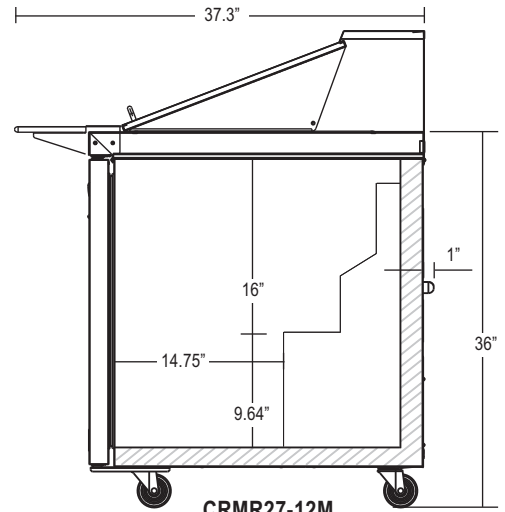

**CRMR27-12M
SIDE
(Cross Section)**

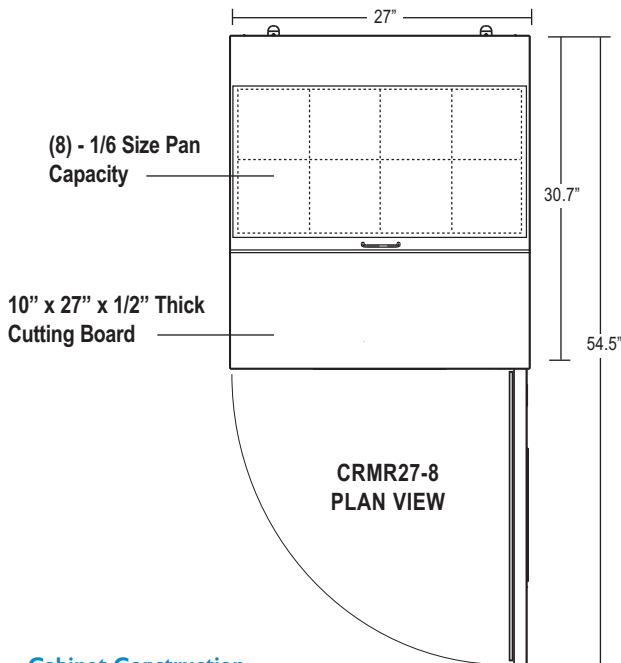

**CRMR27-8
PLAN VIEW**

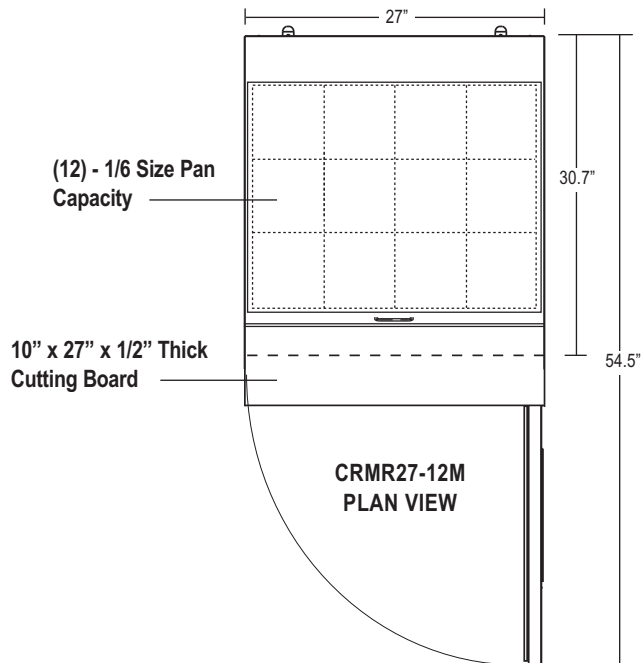

**CRMR27-12M
PLAN VIEW**

Cabinet Construction

The exterior cabinet top, front, and sides, are constructed of high quality stainless steel. Cabinet is provided with a stainless steel top enclosure and an easily removable insulated lift-up cover. The exterior back and bottom are constructed of coated steel. The cabinet interior back and sides are anodized aluminum with an ABS ceiling and stainless steel floor. One heavy duty epoxy coated shelf per section is standard. Mounted on anodized aluminum pilasters the shelf is adjustable in 1/2" increments. Cabinet walls and doors are insulated with 2" of environmentally friendly, CFC free, foamed in place polyurethane. 6" polyolefin, stem casters (two with brakes) are standard. Preparation tables are supplied with a 27" x 10" x 1/2" thick N.S.F. approved white polyethylene cutting board.

Door Construction

Doors are constructed of high grade stainless steel exterior with an ABS interior liner. Hoshizaki's exclusive "stepped" design protects the gasket while product is removed from the cabinet. Doors are provided with a one piece, extruded aluminum, flush mount handle. Spring assisted self-closing doors are equipped with a stay open feature past 90 degrees. Snap-in magnetic door gaskets are durable and easily removed for cleaning. Field reversible door hinging is standard.

Refrigeration System

Front breathing refrigeration system allows unit to be built into any enclosure with zero side and rear clearance. The high efficiency refrigeration system is self-contained with an enamel coated evaporator for extended life. Condensate removal is accomplished with an energy efficient non-electric evaporation system. A capillary tube controls the flow of environmentally friendly R-134A refrigerant through the evaporator. Refrigeration system utilizes an electric time-initiated defrost to eliminate any ice on the evaporator coil. An innovative air distribution system distributes air evenly from beneath the pans. Product temperatures are maintained between 33°F and 41°F at 86° ambient room temperature to comply with N.S.F.7. Preparation tables are supplied with a full complement of N.S.F. approved polycarbonate plastic 1/6" size pans, 4" deep and stainless steel adapter bars. Units will accommodate 6" deep pans. Pans are located 1.5" below the top to keep food product within easy reach. 115 volt units are equipped with an eight foot cord and NEMA rated plug (20.0 amps or less).

© HOSHIZAKI AMERICA, INC.

