



CRMR48/60-D2

Commercial Series Undercounter Refrigerator with Two Drawers and One Door



CRMR48/60-D2
04/17/17
Item # 13420

W x D x H
48" x 30" x 33.63"*
*with 4" casters

W x D x H
60" x 30" x 33.63"*
*with 4" casters

CRMR48-D2



CRMR60-D2



Dimensions / Capacity

	Two Section	
	CRMR48-D2	CRMR60-D2
Interior Storage Capacity (CF)	13.66 ft ³	17.55 ft ³
Interior Storage Capacity (CF) (AHAM)	11.95 ft ³	16.6 ft ³
Overall Width x Depth (including 1" bumper)	48" x 31"	60" x 31"
Height (including 4" casters)	33.63"	33.63"
Door Opening Width x Height	19.5" x 23"	25.5" x 23"
Dept with Drawer Fully Open (including 1" bumper)	50.25"	50.25"
Depth with Door Open at 90° (including 1" bumper)	52.5"	58.5"
Adjustable Shelves / Shelf Dimensions (WxD)	1	1
Shelf Dimensions (W x D)	21.25" x 16"	27.25" x 16"
Crated Weight	241 lbs.	288 lbs.
Crated Width x Depth x Height	52.5" x 34" x 36.5"	62" x 34" x 36.5"

Electrical / Refrigeration

	Two Section	
	CRMR48-D2	CRMR60-D2
Voltage	115/60/1	115/60/1
HACR Breaker	15.0 Amps	15.0 Amps
Electrical Connection (NEMA)	5-15P Ⓢ	5-15P Ⓢ
Voltage Range	104-126	104-126
Ambient Temp. Range	45° to 100°F	45° to 100°F
Control Setpoint Range	32° to 52°F	32° to 52°F
Amperage	2.6	4.2
Energy Consumption (kWh/day) @NSF	2.3	3.3
Heat Rejection (BTU/Hr.) @NSF	327	473.5
Approx. Nominal Compres. BTU/HR (HP)	1029(1/6HP)	1386(1/5HP)
Refrigerant / Charge Amount (oz)	R-134a (6.5 oz)	R-134a (8 oz)

Options

- 2.25" Casters
- Additional epoxy shelves
- 6" Casters
- Overshelves

Warranty

* 3 Year - parts and Labor on entire machine.
5 Year - Parts on Compressor
Valid in United States, Canada, Puerto Rico and U.S. Territories. Contact factory for warranty in other countries.

Item #: _____

Project: _____

Qty: _____

AIA#: _____

Features

- ▶ Engineered to maintain NSF-7 temperatures in 100°F ambient. (Certified to NSF-7 temperatures in 86°F ambient.)
- ▶ Stainless steel exterior front, sides, and top with stainless steel interior sides, back, and floor
- ▶ Front breathing air flow design
 - Cabinet, doors and drawers are insulated with 2" CFC free, foamed in place polyurethane
 - Exclusive "stepped" door design to protect door gasket
 - Extruded aluminum flush mount door handle
 - Field reversible doors
 - Spring assisted self-closing doors with stay open feature
 - Drawer slides are constructed of 16 gauge stainless steel with acetal rollers
 - CRMR48-D2: Drawers will accommodate (1) 1/2 and (1) 1/3 size pans, 6" deep (pan by others)
 - CRMR60-D2: Drawers will accommodate (1) full size pan, 6" deep (pan by others)
 - Magnetic door/drawer gasket is easily removable for cleaning
 - Enamel coated evaporator coil
 - One epoxy coated shelf per door section is standard
 - Anodized aluminum shelf supports adjustable in 1/2" increments
 - Standard with 4" casters (two with brakes)
 - Three year parts and labor warranty
 - Five year compressor warranty
 - 8 ft. cord and plug



CRMR48/60-D2

Commercial Series Undercounter Refrigerator with Two Drawers and One Door



CRMR48/60-D2
04/17/17
Item # 13420

FRONT VIEW

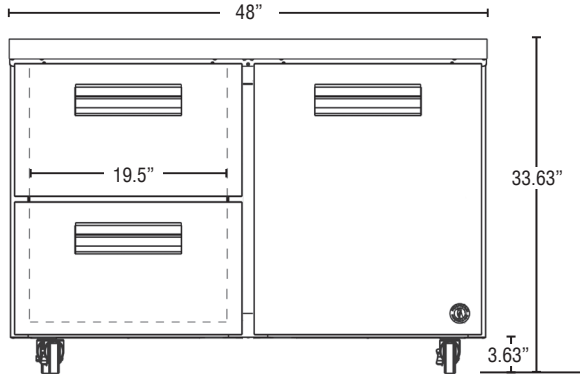

CRMR48-D2

SIDE VIEW

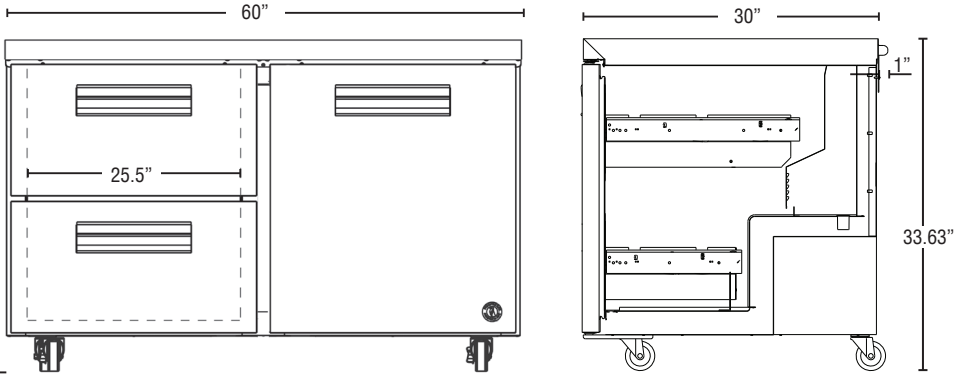

CRMR60-D2

CRMR48/60-D2

PLAN VIEW

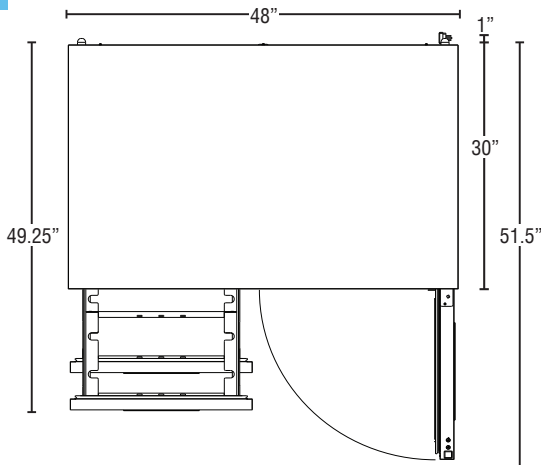

CRMR48-D2

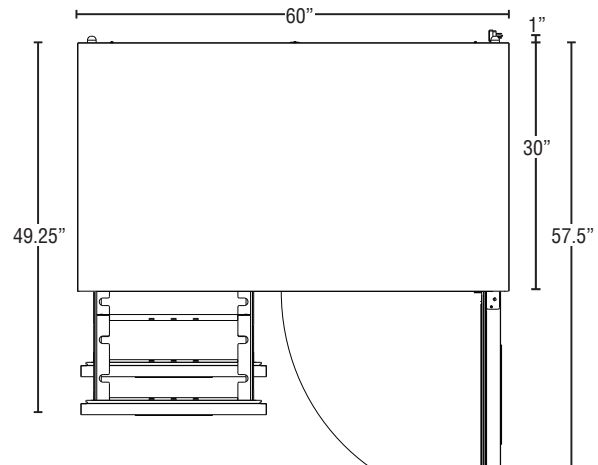

CRMR60-D2

Cabinet Construction

The exterior cabinet top, front, and sides, are constructed of high quality stainless steel. The exterior back and bottom are constructed of coated steel. The cabinet interior features stainless steel back, sides, and floor with an ABS top. One heavy duty epoxy coated shelf per section is standard. Mounted on anodized aluminum pilasters the shelves are adjustable in 1/2" increments. Cabinet walls and doors are insulated with 2" of environmentally friendly, CFC free, foamed in place polyurethane. 4" polyolefin, stem casters (two with brakes) are standard.

Drawer Construction

Drawer fronts are constructed of high grade stainless steel inside and out and are insulated with R-134a CFC free foamed in place polyurethane. CRMR48-D2 drawers will accommodate (1) 1/2 size and (1) 1/3 size pan per drawer, 6" deep (pans by others). CRMR60-D2 drawers will accommodate (1) full size pan, 6" deep (pans by others). Drawer frames are formed of 14 gauge stainless steel and securely fastened in the cabinet. The drawer slides are 16 gauge stainless steel with acetal rollers to prevent metal to metal contact between the drawer slides and reduce wear. The drawer slides have a dynamic load capacity of 175 lbs. and have been life tested (fully loaded) three hundred thousand openings and closings without showing significant wear. The flush mount handles are constructed of extruded aluminum. Snap-in magnetic drawer gaskets are durable and easily removed for cleaning.

Door Construction

Doors are constructed of high grade stainless steel exterior with an ABS interior liner. Hoshizaki's exclusive "stepped" design protects the gasket while product is removed from the cabinet. Doors are provided with a one piece, extruded aluminum, flush mount handle. Spring assisted self-closing doors are equipped with a stay open feature past 90 degrees. Snap-in magnetic door gaskets are durable and easily removed for cleaning. Field reversible door hinging is standard and does not require a kit.

Refrigeration System

The high efficiency refrigeration system is self-contained with an enamel coated evaporator for extended life. Condensate removal is accomplished with an energy efficient non-electric evaporation system. A capillary tube controls the flow of environmentally friendly R-134a refrigerant through the evaporator. Refrigeration system utilizes an "off cycle" defrost to eliminate any ice on the evaporator coil. 115 volt units are equipped with an eight foot cord and plug (20.0 amps or less).

Printed in the U.S.A.