



CRMR48-GLP01

Commercial Series Undercounter Glass Door Refrigerator



CRMR48-GLP01
03/12/18
Item # 13189

W x D x H
48" x 31" x 31.9"*
*with 2.25" casters

CRMR48-GLP01



Dimensions / Capacity

	One Section CRMR48-GLP01
Interior Storage Capacity (CF)	13.66 ft ³
Interior Storage Capacity (CF) (AHAM)	11.95 ft ³
Overall Width x Depth (including 1" bumper & handle)	48" x 32"
Height (including 2.25" casters)	31.9"
Door Opening Width x Height	19.5" x 23"
Depth with Door Open at 90° (including 1" bumper)	55.5"
Adjustable Shelves	2
Shelf Dimensions (W x D)	21.38" x 16.0"
Crated Shipping Weight	264 lbs.
Crated Width x Depth x Height	52.5" x 34" x 36.5"

Electrical / Refrigeration

	One Section CRMR48-GLP01
Voltage	115/60/1
HACR Breaker	15.0 Amps
Electrical Connection (NEMA)	5-15P ⓘ
Voltage Range	104-126
Ambient Temp. Range	45° to 100°F
Control Setpoint Range	32° to 52°F
Amperage	2.9
Energy Consumption (kWh/day) @ASHRAE	1.87
Heat Rejection (BTU/Hr.) @NSF	393.8
Approx. Nominal Compres. BTU/HR (HP)	1029(1/6HP)
Refrigerant / Charge Amount (oz)	R-134a (5.6 oz)

Options

- Additional epoxy shelves
- Door reversal kit
- Stainless steel shelves
- 4" casters
- 6" casters
- Overshelves

Warranty

- * 3 Year - parts and Labor on entire machine.
 - 5 Year - Parts on Compressor
- Valid in United States, Canada, Puerto Rico and U.S. Territories. Contact factory for warranty in other countries.

Item #: _____

Project: _____

Qty: _____

AIA#: _____

Features

- ▶ Engineered to maintain NSF-7 temperature in 100°F ambient.
 - ▶ Energy efficient LED interior lights with on/off switch
 - ▶ Meets ADA requirements
 - Stainless steel interior and exterior sides and top
 - Cabinet is insulated with 2" of CFC free, foamed in place polyurethane
 - Glass doors with locks are energy efficient multi-pane, argon filled
 - Field reversible glass door (with optional kit)
 - Innovative air distribution system distributes air evenly to maintain product temperature
 - Spring assisted self-closing door with stay open feature
 - One piece, full length chrome handle
 - Front breathing air flow design
 - Magnetic door gasket is easily removable for cleaning
 - Enamel coated evaporator coil
 - Anodized aluminum shelf supports adjustable in 1/2" increments
 - Standard with 2.25" casters (two with brakes)
 - Three year parts and labor warranty
 - Five year compressor warranty
 - 8 ft. cord and plug
- Note: Made to order. Allow 4-6 weeks.



CRMR48-GLP01

Commercial Series Undercounter Glass Door Refrigerator



CRMR48-GLP01
03/12/18
Item # 13189

FRONT VIEW

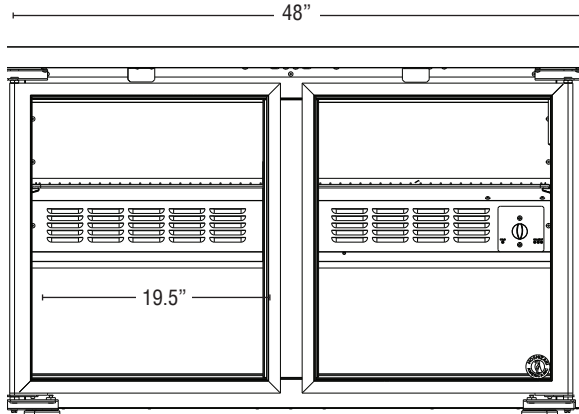

CRMR48-GLP01

SIDE VIEW

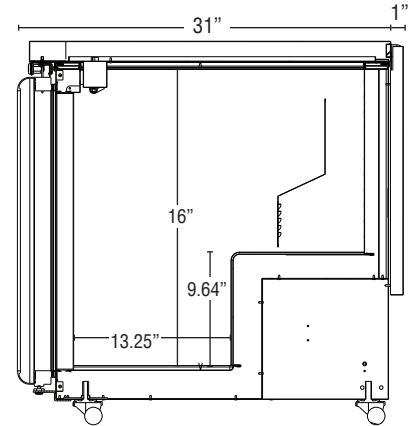

CRMR48-GLP01

PLAN VIEW

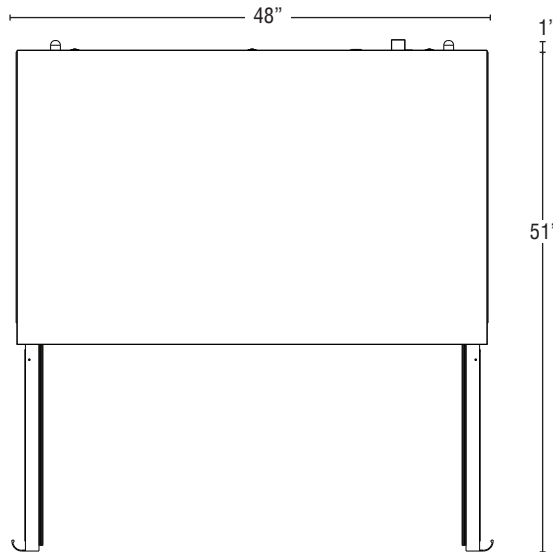

CRMR48-GLP01

Cabinet Construction

The exterior cabinet top, front, and sides, are constructed of high quality stainless steel. The exterior back and bottom are constructed of coated steel. The cabinet interior features stainless steel back, sides, floor and ceiling. One heavy duty epoxy coated shelf per section is standard. Mounted on anodized aluminum pilasters the shelf is adjustable in 1/2" increments. Cabinet walls and doors are insulated with 2" of environmentally friendly, CFC free, foamed in place polyurethane. 2.25" polyolefin, stem casters (two with brakes) are standard.

Door Construction

Glass doors are constructed of high grade silver anodized aluminum with a full length chrome handle. Door glass is energy efficient multi pane, argon filled with locks. The door hinges are all metal and include an adjustable torsion spring closure that will not wear out like traditional cam-lift hinges. Hinge plates are constructed of heavy duty stainless steel. Doors stay open at 90° and are self-closing at 75°. Snap-in magnetic door gaskets are durable and easily removed for cleaning. Door hinging is field reversible (with an optional door reversal hinge kit).

Refrigeration System

The high efficiency refrigeration system is self-contained with an enamel coated evaporator for extended life. Condensate removal is accomplished with an energy efficient non-electric evaporation system. A capillary tube controls the flow of environmentally friendly R-134A refrigerant through the evaporator. Refrigeration system utilizes an "off cycle" defrost to eliminate any ice on the evaporator coil. 115 volt units are equipped with an eight foot cord and plug (20.0 amps or less).

Printed in the U.S.A.