

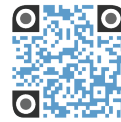

CRMR60-24MD4

Commercial Series Mega Top Refrigerator with Drawers



CRMR60-24MD4
11/03/17
Item # 13355

W x D x H
60" x 30" x 44.25"*
*with 6" casters

CRMR60-24MD4



Dimensions / Capacity

Two Section CRMR60-24MD4

Interior Storage Capacity (CF)	17.55 ft ³
Interior Storage Capacity (CF) (AHAM)	16.6 ft ³
Overall Width x Depth (including 1" bumper)	60" x 31"
Height (including 6" casters)	44.25"
Depth with Cutting Board Installed	37.3"
Drawer Opening Width x Height	25.5" x 22.9"
Depth with Drawer Fully Open (including 1" bumper)	50.25"
Pan Capacity (# of 1/6 size x 4" deep)	24
Maximum Pan Depth	6"
Crated Weight	343 lbs.
Crated Width x Depth x Height	64.5" x 34" x 45.75"

Electrical / Refrigeration

Two Section CRMR60-24MD4

Voltage	115/60/1
HACR Breaker	15.0 Amps
Electrical Connection (NEMA)	5-15P
Voltage Range	104-126
Ambient Temp. Range	45° to 100°F
Control Setpoint Range	32° to 52°F
Amperage	6
Energy Consumption (kWh/day) @NSF	3.9
Heat Rejection (BTU/Hr.) @NSF	556
Approx. Nominal Compress. BTU/HR (HP)	2607(1/3HP)
Refrigerant / Charge Amount (oz)	R-134a (10.3 oz)

Options

- Stainless steel back
- Drawer divider bars
- Rail adapter bars
- Stainless steel lift off covers
- Composite cutting board (HS-5268)
- 2.25" Casters
- 4" Casters
- 6" legs
- Overshelves

Warranty

* 3 Year - parts and Labor on entire machine.
5 Year - Parts on Compressor
Valid in United States, Canada, Puerto Rico and U.S. Territories. Contact factory for warranty in other countries.

Item #: _____
Project: _____
Qty: _____
AIA#: _____

Features

- ▶ Engineered to maintain NSF-7 temperatures in 100°F ambient. (Certified to NSF-7 temperatures in 86°F ambient.)
- ▶ Stainless steel exterior front, sides and top
- ▶ Stainless steel interior sides and back with stainless steel interior floor
 - Cabinet and doors are insulated with 2" CFC free, foamed in place polyurethane
 - Front breathing air flow design
 - Innovative air distribution system distributes air evenly to maintain product temperature
 - Provided with a full complement of polycarbonate plastic 1/6th size pans, 4" deep and adapter bars
 - Rails will also accept 6" deep pans for 50% more pan volume
 - 60" x 10" x 1/2" thick white polyethylene cutting board is standard
 - Drawer slides are constructed of 16 gauge stainless steel with acetal rollers
 - Drawer frames are formed of 14 gauge stainless steel and securely fastened in the cabinet
 - Drawers will accommodate (1) 12" x 20" x 6" deep pan (pans by others)
 - Extruded aluminum flush mount drawer handle
 - Magnetic door gasket is easily removable for cleaning
 - Enamel coated evaporator coil
 - Standard with 6" stem casters (two with brakes)
 - Three year parts and labor warranty
 - Five year compressor warranty
 - 8 ft. cord and plug



CRMR60-24MD4

Commercial Series Mega Top Refrigerator with Drawers

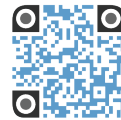

CRMR60-24MD4
11/03/17
Item # 13355

FRONT VIEW

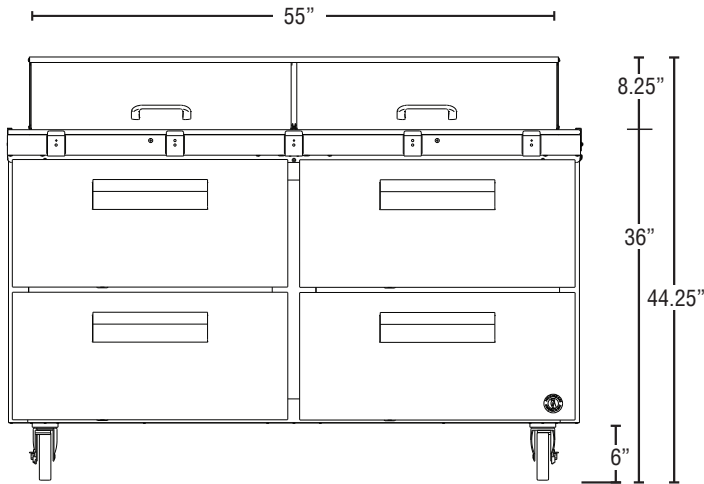

CRMR60-24MD4

SIDE VIEW

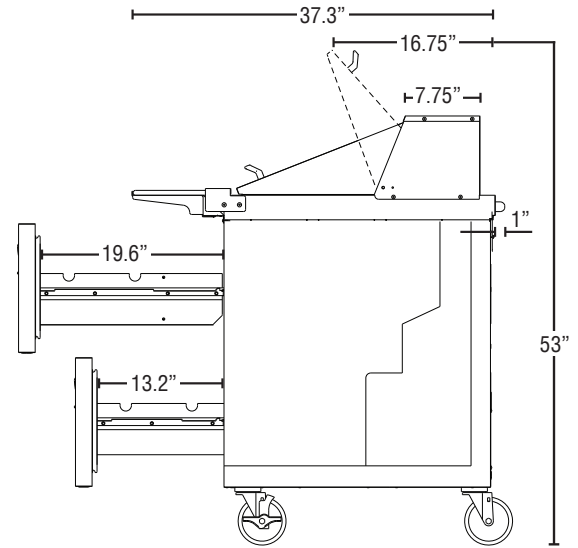

CRMR60-24MD4

PLAN VIEW

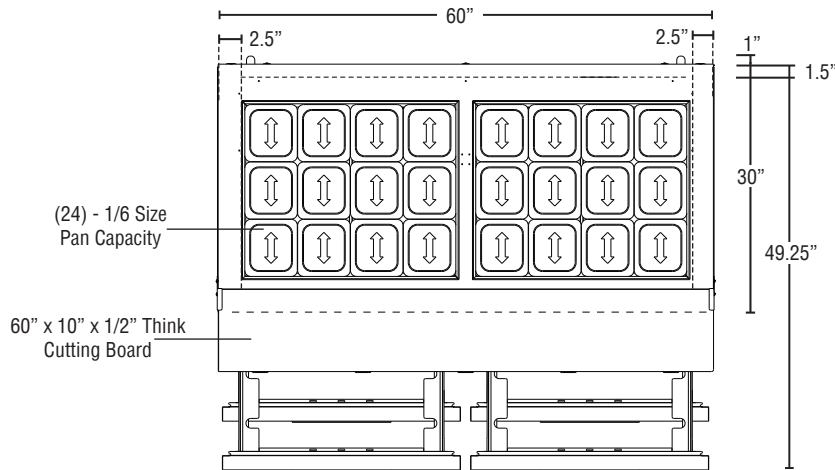

CRMR60-24MD4

Cabinet Construction

The exterior cabinet top, front, and sides, are constructed of high quality stainless steel. Cabinet is provided with a stainless steel top enclosure and an easily removable stainless steel insulated lift-up cover. The exterior back and bottom are constructed of coated steel. The cabinet interior back and sides are stainless steel with an ABS ceiling and stainless steel floor. Cabinet walls and drawers are insulated with 2" of environmentally friendly, CFC free, foamed in place polyurethane. 6" polyolefin, stem casters (two with brakes) are standard. Preparation tables are supplied with a 60" x 10" x 1/2" thick N.S.F. approved white polyethylene cutting board.

Drawer Construction

Drawer fronts are constructed of high grade stainless steel inside with stainless steel interior liners and are insulated with R-134a CFC free foamed in place polyurethane. Each drawer accommodates (1) full size pan per drawer, 6" deep (pans by others). Drawer frames are formed of 14 gauge stainless steel and securely fastened in the cabinet. The drawer slides are constructed of heavy duty 16 gauge stainless steel and durable acetal rollers with stainless steel ball bearings to prevent metal to metal contact. The drawer slides have a dynamic load capacity of 175 lbs. and have been life tested (fully loaded) three hundred thousand openings and closings without showing significant wear. The flush mount handles are constructed of extruded aluminum. Snap-in magnetic drawer gaskets are durable and easily removed for cleaning.

Refrigeration System

Front breathing refrigeration system allows unit to be built in to any enclosure with zero side or rear clearance. The high efficiency refrigeration system is self-contained with an enamel coated evaporator for extended life. Condensate removal is accomplished with an energy efficient non-electric evaporation system. A capillary tube controls the flow of environmentally friendly R-134a refrigerant through the evaporator. Refrigeration system utilizes a heated defrost to eliminate any ice on the evaporator coil. An innovative air distribution system distributes air evenly around the pans. Engineered to maintain NSF-7 temperatures in 100°F ambient. (Certified to NSF-7 temperatures in 86°F ambient.) Preparation tables are supplied with a full complement of N.S.F. approved plastic 1/6 size pans, 4" deep and stainless steel adapter bars. Units will also accommodate 6" deep pans. Pans are located 1.5" below the top to keep food product within easy reach. 115 volt units are equipped with an eight foot cord and NEMA rated plug (20.0 amps or less).

Printed in the U.S.A.