



CRMR72-D6

Commercial Series Worktop Refrigerators with Drawers



CRMR72-D6
4/13/17
Item # 13357

W x D x H
72" x 30" x 33.63"*
*with 4" casters

CRMR72-D6



Dimensions / Capacity

Three Section CRMR72-D6

Interior Storage Capacity (CF)	21.25 ft ³
Interior Storage Capacity (CF) (AHAM)	19.7 ft ³
Overall Width x Depth (including 1" bumper)	72" x 31"
Height (including 6" casters)	33.63"
Door Opening Width x Height	19.5" x 22.9"
Depth with Drawer Fully Open (including 1" bumper)	50.25"
Pan Capacity (pans by others)	(1) 1/2 size pan and (1) 1/3 size pan
Crated Weight	372 lbs.
Crated Width x Depth x Height	74" x 34" x 36.5"

Electrical / Refrigeration

Three Section CRMR72-D6

Voltage	115/60/1
HACR Breaker	15.0 Amps
Electrical Connection (NEMA)	5-15P Ⓢ
Voltage Range	104-126
Ambient Temp. Range	45° to 100°F
Control Setpoint Range	32° to 52°F
Amperage	4.2
Energy Consumption (kWh/day) @NSF	4.5
Heat Rejection (BTU/Hr.) @NSF	647
Approx. Nominal Compres. BTU/HR (HP)	1386(1/5HP)
Refrigerant / Charge Amount (oz)	R-134a (8 oz)

Options

Warranty

- 2.25" Casters
- 4" Casters
- 6" Legs
- Overshelves
- Drawer divider bars

* 3 Year - parts and Labor on entire machine.
5 Year - Parts on Compressor
Valid in United States, Canada, Puerto Rico and U.S. Territories. Contact factory for warranty in other countries.

Item #: _____
Project: _____
Qty: _____
AIA#: _____

Features

- ▶ Engineered to maintain NSF-7 temperatures in 100°F ambient. (Certified to NSF-7 temperatures in 86°F ambient.)
- ▶ Stainless steel exterior front, sides, and top with stainless steel interior sides, back, and floor
- ▶ Front breathing air flow design
 - Cabinet and drawers are insulated with 2" CFC free, foamed in place polyurethane
 - Drawer slides are constructed of 16 gauge stainless steel with acetal rollers
 - Drawers will accommodate (1) 1/2 size pan and (1) 1/3 size pan (pan by others)
 - Extruded aluminum flush mount drawer handle
 - Magnetic drawer gasket is easily removable for cleaning
 - Enamel coated evaporator coil
 - Standard with 6" casters (two with brakes)
 - Three year parts and labor warranty
 - Five year compressor warranty
 - 8 ft. cord and plug



CRMR72-D6

Commercial Series Worktop Refrigerators with Drawers



CRMR72-D6
4/13/17
Item # 13357

FRONT VIEW

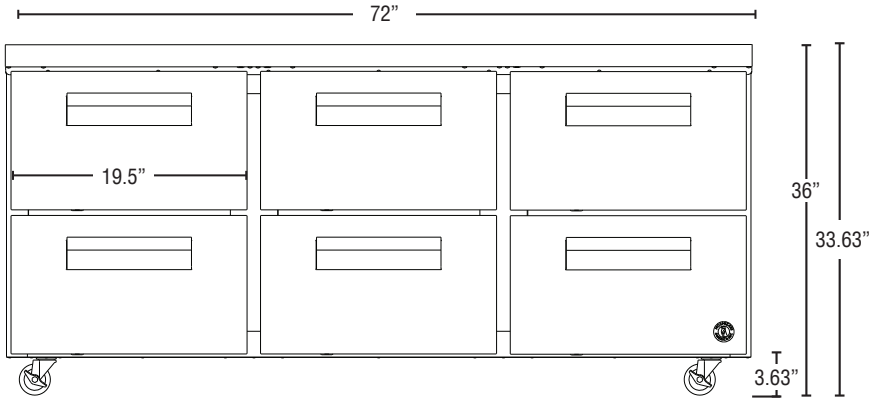

CRMR72-D6

SIDE VIEW

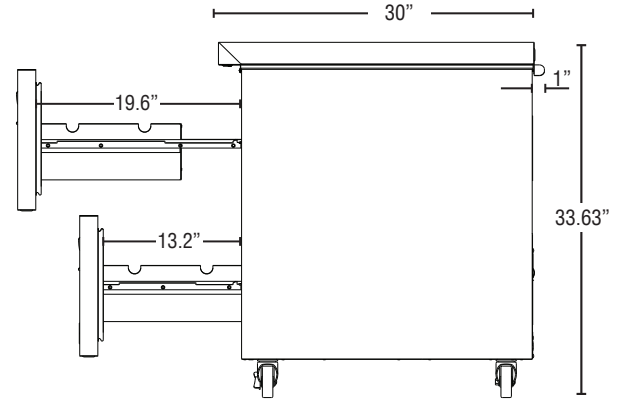

CRMR72-D6

PLAN VIEW

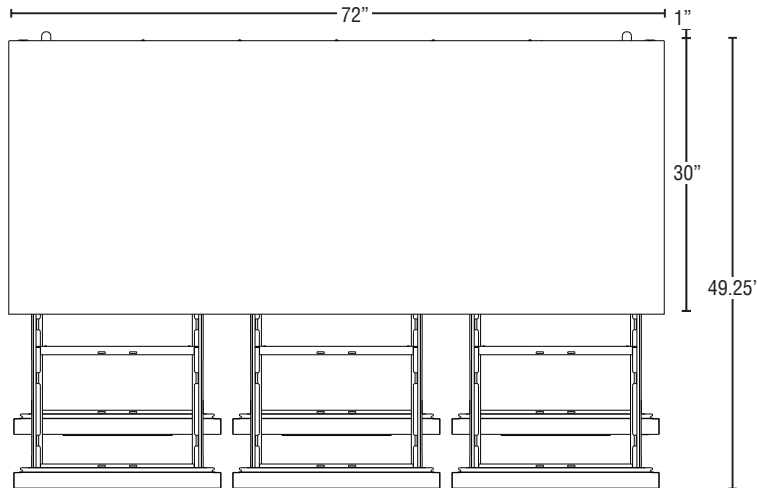

CRMR72-D6

Cabinet Construction

The exterior cabinet top, front, and sides, are constructed of high quality stainless steel. The exterior back and bottom are constructed of coated steel. The cabinet interior features stainless steel back, sides, and floor with an ABS top. Cabinet walls and drawers are insulated with 2" of environmentally friendly, CFC free, foamed in place polyurethane. 4" polyolefin, stem casters (two with brakes) are standard.

Drawer Construction

Drawer fronts are constructed of high grade stainless steel inside and out and are insulated with R-134a CFC free foamed in place polyurethane. Each drawer accommodates (1) 1/2 size pan and (1) 1/3 size pan (pans by others). Drawer frames are formed of 14 gauge stainless steel and securely fastened in the cabinet. The drawer slides are constructed of heavy duty 16 gauge stainless steel with durable acetal rollers with stainless steel bearings to prevent metal to metal contact. The drawer slides have a dynamic load capacity of 175 lbs. and have been life tested (fully loaded) three hundred thousand cycles without significant wear. The flush mount handles are constructed of extruded aluminum. Snap-in magnetic drawer gaskets are durable and easily removed for cleaning.

Refrigeration System

The high efficiency refrigeration system is self-contained with an enamel coated evaporator for extended life. Condensate removal is accomplished with an energy efficient non-electric evaporation system. A capillary tube controls the flow of environmentally friendly R-134A refrigerant through the evaporator. Refrigeration system utilizes a heated defrost to eliminate any ice on the evaporator coil. 115 volt units are equipped with an eight foot cord and plug (20.0 amps or less).

Printed in the U.S.A.