



FS-1500MLJ-C

SERENITY SERIES CUBELET ICE MACHINE



FS-1500MLJ-C
05/06/19
Item # 13461

Item #: _____
Project: _____
Qty: _____
AIA#: _____

Modular Head Unit
W x D x H
30" x 16 1/2" x 33"

Remote Unit Dimension
SRC-14J
35 3/4" x 23 1/2" x 22"

Installation Dimension*
SRC-14J
38" x 29" x 37"

*Dimensions include legs



FS-1500MLJ-C
Remote Air-Cooled
Shown on Lancer Sensation
30" Dispenser

Features

- ▶ Durable stainless steel exterior
- ▶ Advanced CleanCycle24™ design 
- ▶ Stainless steel auger with greaseless bearing

- Up to 1386 lbs. of ice production per 24 hours
- Durable stainless steel exterior
- EverCheck™ alert system
- Less heat in the kitchen
- Minimized noise
- 2-second flush cycle every hour
- Flush cycle removes sediment for cleaner ice
- Slim depth - easier to clean dispenser
- Front and back serviceability
- 10 ft. power cord with NEMA 5-15P plug
- R-404A Refrigerant

Warranty:

3 Year Parts & Labor on entire machine. 5 Year Parts on Compressor; air-cooled condenser coil. Valid in United States, Canada, Puerto Rico and U.S. Territories. Contact factory for warranty in other countries.

Shipping: (LxWxH) 35" x 23.25" X 39.5" Volume: 12.25ft³



Condenser	Model	ICE PRODUCTION		WATER USAGE		ELECTRICAL					Refrigerant Charge Amount	Net / Ship Weight (lbs.)
		Air / Water Temp Lbs. per 24 hours 70°/ 50°F	90°/ 70°F	Potable Gal. per 100 lbs.	Condenser Gal. per 100 lbs.	kWh Used per 100 lbs.	Min. Circuit Amp - Max. Fuse/Breaker	Amperage	Voltage	Circuit Wires (including ground)		
Remote	FS-1500MLJ-C	1386	1125	12.0	N/A	4.75	15A	3.6A	115V/60/1 *	3	3.5 oz.	182/222

Condenser	Model	LINE SETS - Brazing Required			TEMP RANGE	ELECTRICAL							
		25' Length	35' Length	55' Length	Ambient (Outdoor Use)	Voltage Range	Min. Circuit Amp - Max. Fuse/Breaker	Amperage	Voltage	Circuit Wires (including ground)	Heat Rejection BTU/hr.	Refrigerant Charge Amount	Net / Ship Weight (lbs.)
Remote	SRC-14J	HS-5323†	HS-5324†	HS-5325†	-4° - 122°	187-253VAC	20A	10.1A	208-230V/60/1	4	15,300	10 lb. 12.8 oz.	190 /235

* Line sets require refrigerant. Refer to instruction manual for installation and electrical requirements. See instruction manual for wiring diagram.

10ft. power cord included.

Cubelet Cube Dimensions*

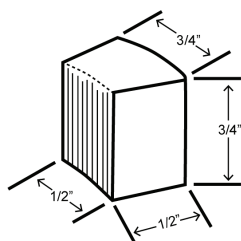

* approximate size in inches, image not to scale

Operating Limits FS-1500MLJ-C

- Ambient Temp Range 45 - 100°F
- Water Temp Range 45 - 90°F
- Water Pressure 10 - 113 PSIG
- Voltage Range 104-127V*

Service FS-1500MLJ-C

- Allow 6" (15 cm) clearance at rear, sides, and top for proper air circulation and ease of maintenance/service.
- Allow 24" (61 cm) clearance on left side for removal of cube guides
- Panels easily removed and all components accessible for service.

Plumbing FS-1500MLJ-C

- Icemaker Water Supply Line: Minimum 1/4" Nominal ID Copper Water Tubing or Equivalent
- Icemaker Drain Line: Minimum 3/4" Nominal ID Hard Pipe or Equivalent

Service- SRC-14J

- Allow 24" (61 cm) clearance in both front and rear for proper air circulation and ease of maintenance/service.
- For best performance the Remote Condenser should not be more than 33 feet above the icemaker or no more than 10 feet below it. These distances are measure from fitting to fitting.

Hoshizaki reserves the right to change specifications without notice.



FS-1500MLJ-C

SERENITY SERIES CUBELET ICE MACHINE



FS-1500MLJ-C
05/06/19
Item # 13461

FRONT VIEW

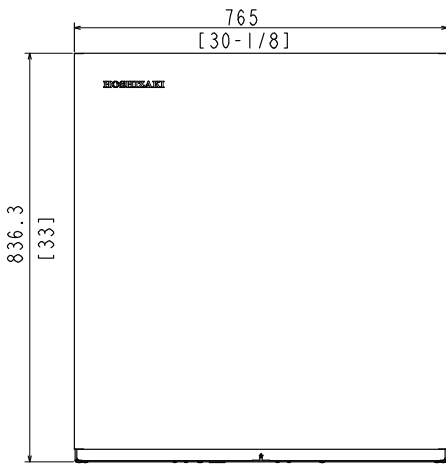

FS-1500MLJ-C

SIDE VIEW

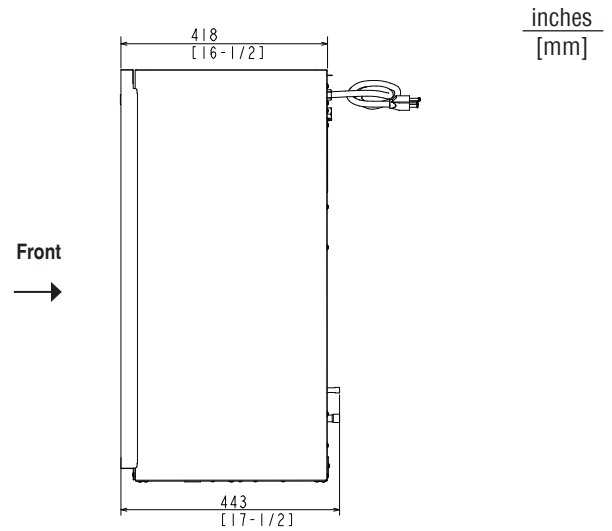

REAR VIEW

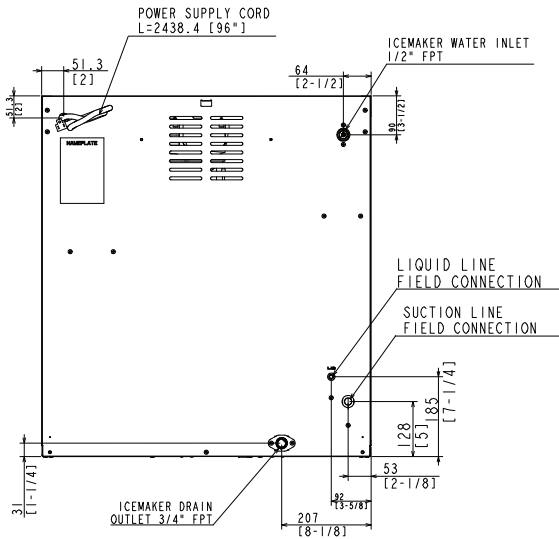

FS-1500MLJ-C

FRONT VIEW

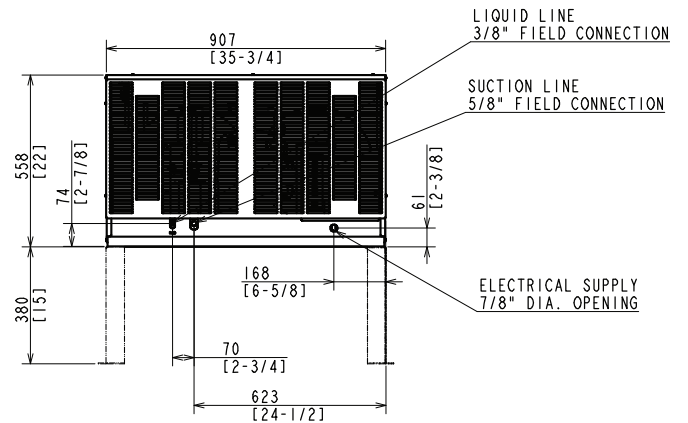

SRK-14J REMOTE CONDENSER

BOTTOM VIEW

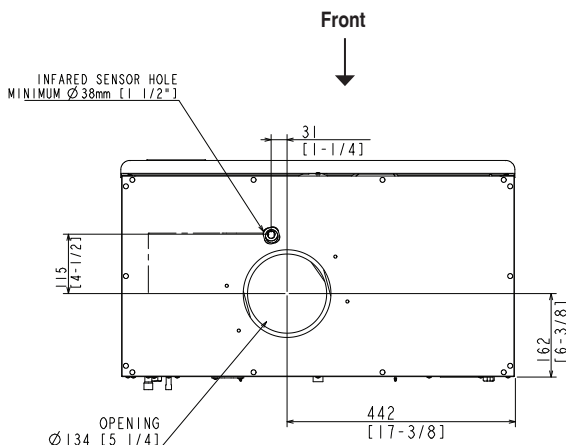

FS-1500MLJ-C



Braided Line Sets (Sold Separately)
25' HS-5323
35' HS-5324
55' HS-5325

Voltage supply for ice maker and condensing unit are separate.

SRC-14J Remote Condenser (Sold Separately)
(W x D x H) 37 3/4 x 26 5/8 x 37 (including legs)
For Use with FS-1500MLJ-C

