



KM-901MAH50

MODULAR CRESCENT CUBER



KM-901MAH50
10/30/17
Item # 13268

W x D x H
76.2 x 69.5 x 95.1 cm

Shipping Dimensions
88.5 x 83.8 x 109.2 cm

KM-901MAH50
Air-Cooled



Shown on optional bin B-900



Item #: _____
Project: _____
Qty: _____
AIA#: _____

Features

- ▶ Individual crescent cube
- ▶ Stainless steel evaporator
- ▶ CycleSaver™ design 

- Up to 398 kg. of ice production per 24 hours
- Durable stainless steel exterior
- Protected by H-GUARD Plus  Antimicrobial Agent
- EverCheck™ alert system 
- Removable air filters
- R-404A Refrigerant

Available on Bins:

B-250PF B-700PF/SF B-900PF/SF B-1300SS B-1650SS*
B-500PF/SF B-800PF/SF B-1150SS B-1500SS*

Top kit may be required. See Bin Spec Sheets. *Two unit application only.

Warranty:

Call factory for warranty information.



Condenser	Model	ICE PRODUCTION		WATER USAGE		ELECTRICAL *					Heat Rejection BTU/hr.	Charge Amount	Net / Ship Weight (kg.)
		Air / Water Temp kg per 24 hours 21° / 10°C 32° / 21°C		Potable Liters per 45 kg 32° / 21°C	Condenser Liters per 45 kg 32° / 21°C	kWh Used per 45 kg 32° / 21°C	Max. Fuse Size or HACR Circuit Breaker	Amperage	Voltage	Circuit Wires (including ground)			
Air	KM-901MAH50	398	320	60	N/A	2.31	20A	9.0A	208-230V/50/1	3	15,600	1320g	89 / 116 kg

*If neutral is not available transformer kit (HS-5030) is required. Refer to instruction manual for installation and electrical requirements.

KM Cube Dimensions*

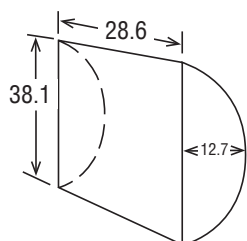

* approximate size in millimeters, image not to scale

Operating Limits

- Ambient Temp Range 7 - 38°C
- Water Temp Range 7 - 32°C
- Water Pressure 0.7 - 8 kg/cm²
- Voltage Range 198 - 254V

Service

- Panels easily removed and all components accessible for service.
- Allow 15 cm clearance at rear, sides, and top for proper air circulation and ease of maintenance/service.
- Removable/cleanable air filters under front panel (Air-cooled model only)

Plumbing

- Icemaker Water Supply Line: Min. 6 mm Nominal OD Copper Water Tubing or Equivalent
- Icemaker Drain Line: Min. 18 mm Nominal OD Hard Pipe or Equivalent

Water Filter

Please refer to water filter spec sheet for recommended configurations.



KM-901MAH50

MODULAR CRESCENT CUBER



KM-901MAH50
10/30/17
Item # 13268

FRONT VIEW

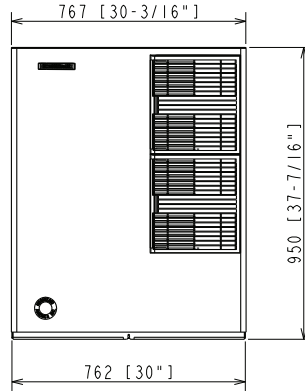

AIR-COOLED

SIDE VIEW

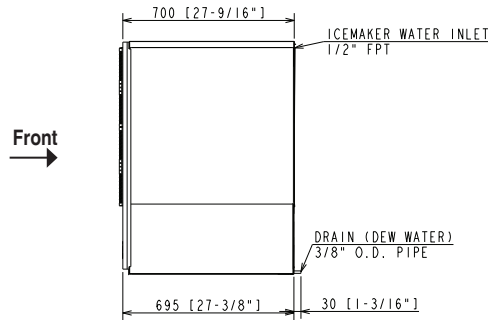

AIR-COOLED

REAR VIEW

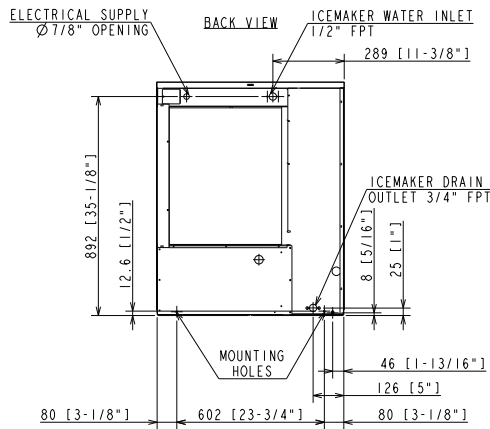

AIR-COOLED

BOTTOM VIEW

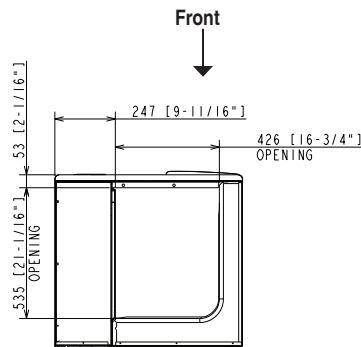

AIR-COOLED