



# RM-10

## Glass Door Merchandiser with Swing Door



RM-10  
04/04/18  
Item # 13410

**W x D x H**  
25.5" x 22.75" x 55.5"

**RM-10**



### Dimensions / Capacity

	One Section RM-10
Interior Storage Capacity (CF)	10 ft <sup>3</sup>
Overall Width x Depth	25.5" x 23"
Height	55.5"
Depth with Door Open	46.7"
Adjustable Shelves	3
Shelf Dimensions (W x D)	21.25" x 17.5"
Crated Shipping Weight	206 lbs.
Crated Width x Depth x Height	30" x 28" x 60"

### Electrical / Refrigeration

	One Section RM-10
Voltage	115/60/1
HACR Breaker	15.0 Amps
Electrical Connection (NEMA)	5-15P (Ⓜ)
Voltage Range	104-126
Ambient Temp. Range	60° to 86°F
Control Setpoint Range	34° to 40°F
Amperage	3.7
Energy Consumption (kWh/day) @ASHRAE	1.24
Approx. Nominal Compress. BTU/HR (HP)	705 (1/5HP)
Refrigerant / Charge Amount (oz)	R-134a / 3.5oz.

### Options

- Organizer shelf (HS-5289)
- Price tag holder (HS-5290)
- Epoxy Shelf (HS-5316)
- 4" Casters (HS-5288)
- 2.25" Casters (HS-5037)

### Warranty

\* 3 Year - Parts and Labor on entire machine.  
5 Year - Parts on Compressor  
Valid in United States, Canada, Puerto Rico and U.S. Territories. Contact factory for warranty in other countries.

Item #: \_\_\_\_\_  
Project: \_\_\_\_\_  
Qty: \_\_\_\_\_  
AIA#: \_\_\_\_\_

## Features

- ▶ **Curved vertical corners with silver aluminum exterior provide enhanced product display**
- ▶ **Electronic controller with visual and audio high and low temperature alarms**
- ▶ **Forced air evaporator for quick temperature pull down**
  - Listed under NSF/ANSI Standard 7 for the storage and/or display of packaged or bottled products.
  - Large glass door is energy efficient Low-E multi pane glass
  - Door is mounted on heavy duty hinges with self-closing mechanism
  - Automatic energy saving hot gas loop on front edge of refrigeration compartment helps prevent condensation particularly in hot humid environments
  - Energy efficient vertical LED interior lights illuminate products on display
  - Silver painted aluminum exterior with NSF approved white steel interior and stainless steel floor
  - Electronic controller with energy saving mode will save approximately 40% energy consumption during non-peak hours
  - Environmentally friendly CFC-Free Polyurethane insulation with cyclopentane blowing agent.
  - (3) white epoxy coated shelves per section with product stops are standard
  - Stackable (two units high) to conserve warehouse floor space
  - Stainless steel shelf clips adjustable in 1/2" increments on anodized aluminum supports
  - Refrigerant flow is controlled with a capillary tube
  - 8 Foot cord and plug
  - 2 inch leveling legs standard
  - Three years parts and labor warranty
  - Five-year compressor warranty

Capacity:  
20 oz. bottles: 126  
12 oz. bottles: 288



# RM-10

## Refrigerated Merchandiser - 10 cu.ft.



RM-10  
04/04/18  
Item # 13410

### FRONT VIEW

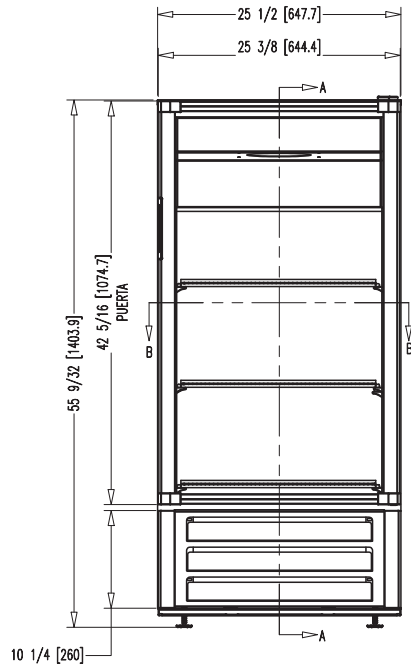

### SIDE VIEW

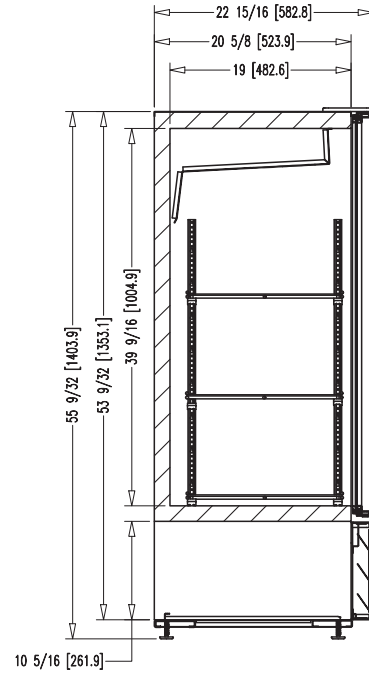

### PLAN VIEW

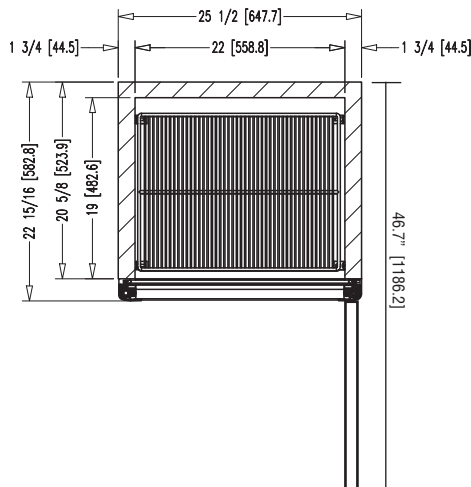

### HEADER DIMS

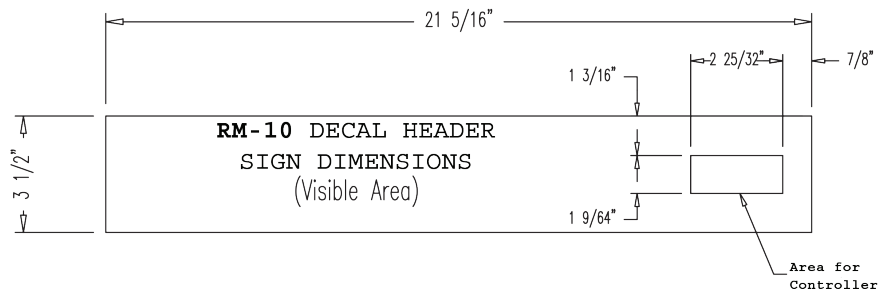

#### Graphic Requirements:

- 360 dpi resolution. Scale 1=1
- Colors for CMYK process
- Image with 1/4" of excess by side
- Graphics must be saved in photoshop (with layers)
  - (or your sign company file type requirements)
- Include a full color print out

#### Material Requirements:

- 3M exterior grade UV resistant vinyl adhesive

Note: Texts and important parts of the image should be within the visible area.  
The visible area is illustrated by dotted lines when it applies.