



# HOSHIZAKI

## Parts List

Commercial Series  
Refrigerated Kitchen Equipment

### Models

CPT46(-D)

CPT67(-D2)(-D4)

CPT93(-D2)(-D4)(-D6)



[hoshizakiamerica.com](http://hoshizakiamerica.com)

Number: 71352  
Issued: 4-24-2014  
Revised: 9-19-2019

# CONTENTS

Auxiliary Codes.....	3
Note About Ordering Parts .....	4
A. Main Assembly .....	5
CPT46(-D) .....	5
CPT67(-D2)(-D4).....	7
CPT93(-D2)(-D4)(-D6).....	9
B. Refrigeration Circuit.....	11
CPT46(-D) .....	11
CPT67(-D2)(-D4).....	13
CPT93(-D2)(-D4)(-D6).....	15
C. Door-Right Hinged.....	17
D. Door-Left Hinged .....	19
E. Drawer Assembly .....	21
F. Accessories & Labels.....	22

## Auxiliary Codes

### CPT46

D-5 March 2014  
D-6 July 2014  
E-5 March 2015  
E-6 August 2015  
F-5 February 2016  
F-6 June 2016  
G-5 March 2017  
G-6 May 2017  
G-7 November 2017  
H-5 January 2018  
H-6 July 2018

### CPT46-D

D-5 April 2014  
D-6 July 2014  
F-5 April 2016  
F-6 June 2016  
G-5 February 2017  
G-6 May 2017  
H-5 January 2018  
H-6 July 2018  
H-7 October 2018

### CPT67

C-5 September 2013  
D-5 January 2014  
D-6 March 2014  
D-7 August 2014  
E-5 January 2015  
E-6 August 2015  
F-5 January 2016  
F-6 June 2016  
F-7 November 2016  
G-5 January 2017  
G-6 May 2017  
G-7 November 2017  
G-8 December 2017  
H-5 January 2018  
H-6 July 2018

### CPT67-D2

G-5 February 2017  
G-6 May 2017  
G-7 November 2017  
G-8 December 2017  
H-5 February 2018  
H-6 July 2018  
H-7 October 2018

### CPT67-D4

D-6 March 2014  
D-7 September 2014  
E-6 March 2015  
E-7 August 2015  
F-5 March 2016  
F-6 June 2016  
F-7 November 2016  
G-5 January 2017  
G-6 May 2017  
G-7 November 2017  
G-8 December 2017  
H-5 January 2018  
H-6 July 2018  
H-7 October 2018

### CPT93

D-5 February 2014  
D-6 March 2014  
D-7 August 2014  
E-5 January 2015  
E-6 September 2015  
F-5 January 2016  
F-6 June 2016  
F-7 December 2016  
G-5 January 2017  
G-6 May 2017  
G-7 November 2017  
G-8 December 2017  
H-5 January 2018  
H-6 July 2018

### CPT93-D2

G-5 February 2017  
G-6 May 2017  
H-5 January 2018  
H-6 July 2018  
H-7 October 2018

### CPT93-D4

G-5 February 2017  
G-6 May 2017  
H-5 January 2018  
H-6 August 2018  
H-7 October 2018

### CPT93-D6

D-6 March 2014  
E-6 March 2015  
F-5 May 2016  
F-6 August 2016  
F-7 December 2016  
G-5 January 2017  
G-6 May 2017  
G-7 November 2017  
G-8 December 2017  
H-5 February 2018  
H-6 July 2018  
H-7 October 2018

## **Auxiliary Code Breakdown**

The auxiliary code is the first two characters in the serial number. The first character indicates the year. Years progress or regress in alphabetical order. The series runs from "A" through "V" and the letters "I" and "O" are skipped. The second character indicates significant part changes within a year. Base is "5" and this number advances for each change. In cases where there is a letter in parentheses, this designates the month. This is the last character in the serial number. The series runs from "(A)" through "(M)" and the letter "(I)" is skipped. This designation is only included when identifying a parts change within an auxiliary code.

## **Note About Ordering Parts**

Most assemblies cannot be ordered as complete units; parts in the assemblies generally must be ordered separately.

**A. Main Assembly**  
**CPT46(-D)**  
 D-5 to H-7

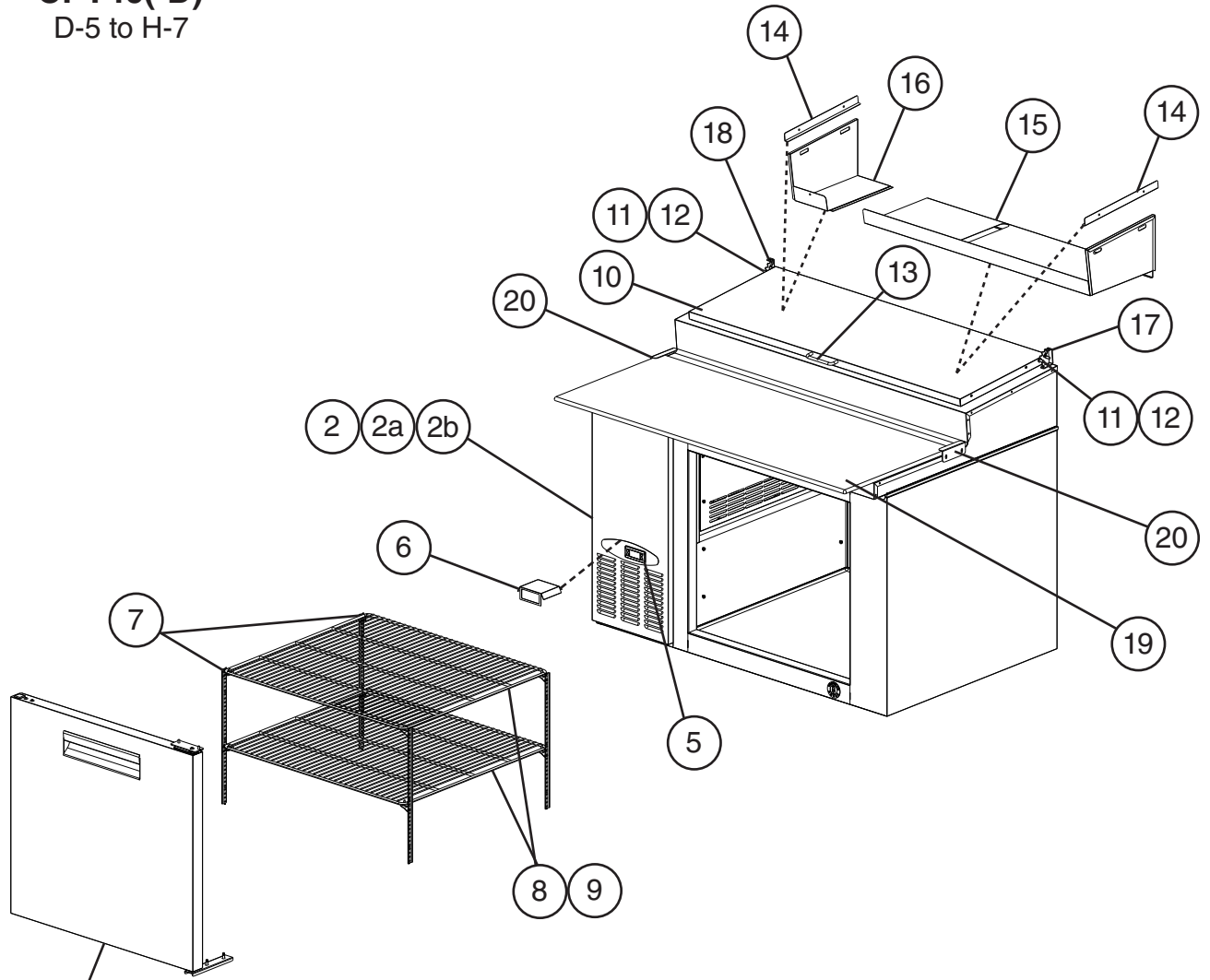

For Door, see Section "C"

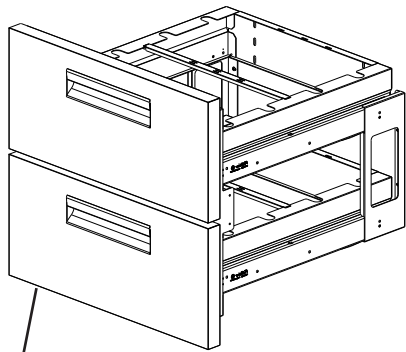

For Drawers, see Section "E"

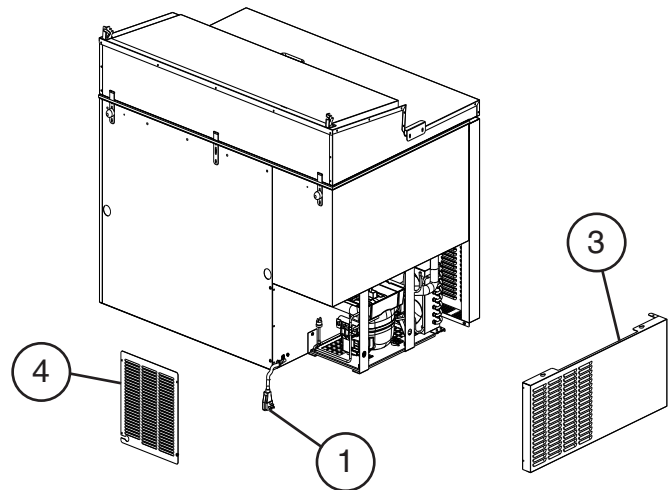

**Title: A. Main Assembly    Models: CPT46(-D)**

Index No.	Description	Material or Model Number	Part Number	Required Number																	
				D-5 to E-5	E-6 to F-5	F-6	G-5 to G-6	G-7 to H-5	H-6 to H-7												
1	Power Cord		4A2860-01	1	1	1	1	1	1												
2	Front Panel		2A8533-01	1	-	Auxiliary Code E-5 and earlier must also order SP-5168															
					1	1	1	1	1												
2a	Front Panel Latch		4A0508-03	4	2	2	2	2	2												
2b	Front Panel Striker		4A0515-01	4	2	2	2	2	2												
3	Left Side Panel		2A7066-01	1	-																
			2A7902-01		1	1	1	1	1												
4	Rear Louver Panel		3A7482-01	1	1	1	1	1	1												
5	Control Module		SP-5212	1	1	-															
			4A5914G01			1	1	1	1												
6	Deflector		3A9649-01					1	1												
7	Pilaster	<b>CPT46</b>	4A5583-01	4	4	4	4	4	4												
8	Shelf	<b>CPT46</b>	3A2830-13	2	2	2	2	2	2												
9	Shelf Clip	<b>CPT46</b>	4A5418-01	8	8	8	8	8	8												
10	Rail Cover (includes items 11, 12, and 13)		2A7212A01	1	1	1	-														
			2A8332A01				1	1	1												
11	Pivot Pin		4A4768-01	4	4	4	4	4	4												
12	Pivot Bolt		4A4769-01	4	4	4	4	4	4												
13	Handle		4A4518-01	1	1	1	1	1	1												
14	Pan Support Bracket		3A7687-02	2	2	2	2	2	2												
15	Right Upper Air Duct		1A3188-01	1	1	-															
			1A4252-01			1	1	1	-												
			1A5295-01							1											
16	Left Upper Air Duct		1A3141-01	1	1	1	1	1	-												
			2A8907-01								1										
17	Right Rail Cover Bracket		4A5596-01	1	1	1	-														
			3A9236-01				1	1	1												
18	Left Rail Cover Bracket		4A5596-02	1	1	1	-														
			3A9236-02				1	1	1												
19	Cutting Board		3A4894-18	1	1	1	1	1	1												
20	Cutting Board Bracket		3A4890-01	2	2	2	2	2	2												

**A. Main Assembly**  
**CPT67(-D2)(-D4)**  
 C-5 to H-7

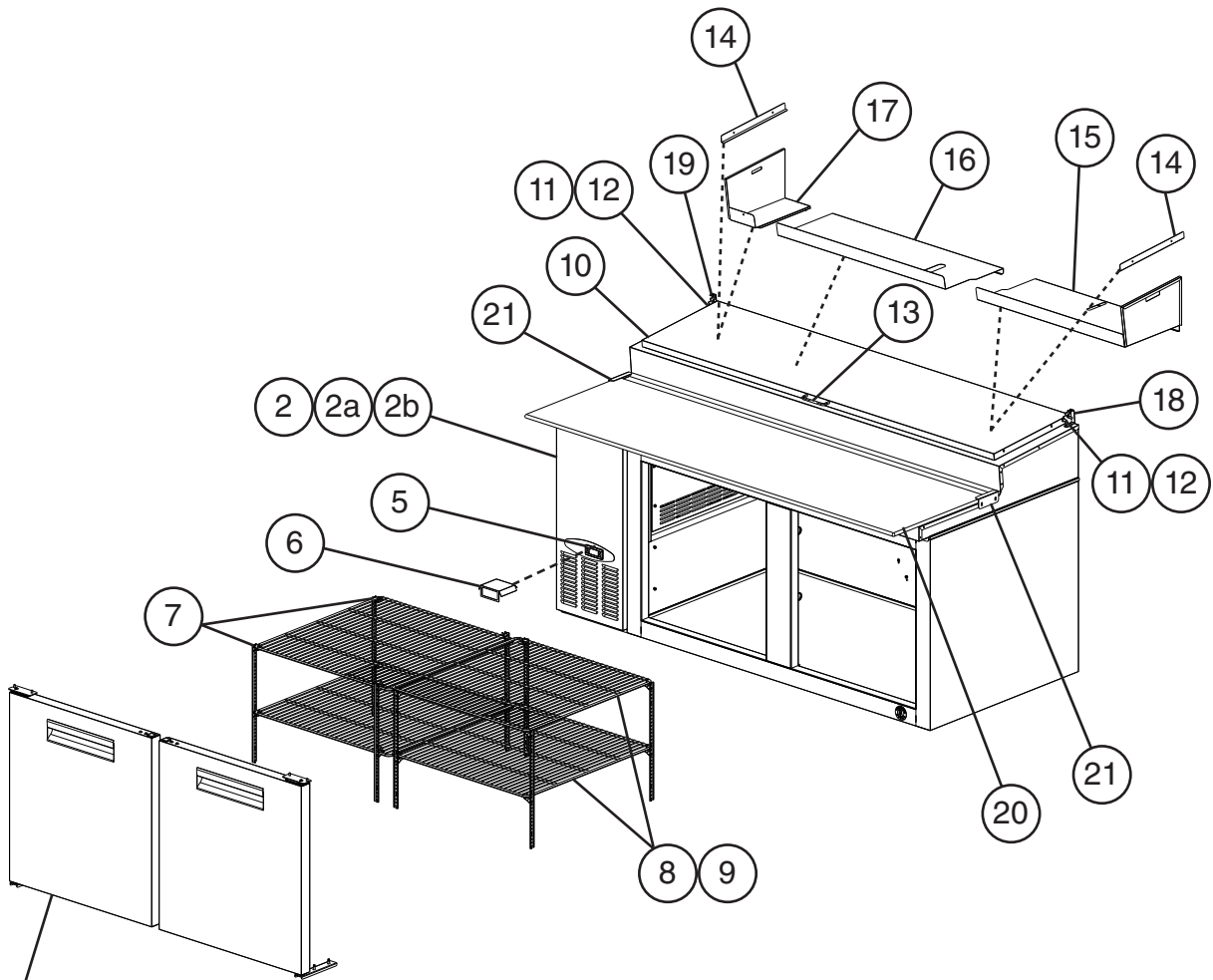

For Doors, see Sections "C" and "D"

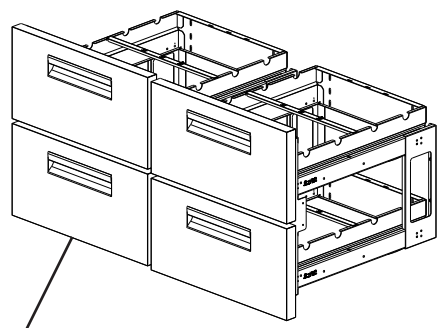

For Drawers, see Section "E"

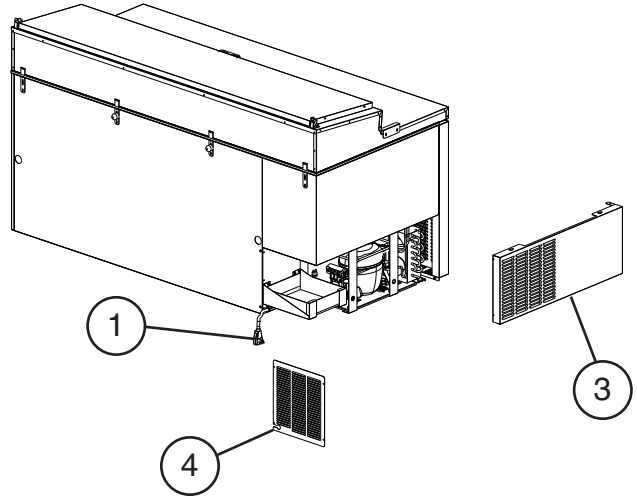

Title: A. Main Assembly Models: CPT67(-D2)(-D4)												
Index No.	Description	Material or Model Number	Part Number	Required Number								
				C-5 to E-5	E-6	E-7 F-5	F-6	F-7	G-5 G-6	G-7 to H-5	H-6 H-7	
1	Power Cord		4A2860-01	1	1	1	1	1	1	1	1	
2	Front Panel	CPT67	2A8533-01	1	-	Auxiliary Code E-5 and earlier must also order SP-5168						
				1	1	1	1	1	1	1	1	
		CPT67(-D2)(-D4)		1	1	-	Auxiliary Code E-6 and earlier must also order SP-5168					
						1	1	1	1	1	1	
2a	Front Panel Latch		4A0508-03	4	2	2	2	2	2	2	2	
2b	Front Panel Striker		4A0515-01	4	2	2	2	2	2	2	2	
3	Left Side Panel		2A7066-01	1	-							
			2A7902-01		1	1	1	1	1	1	1	1
4	Rear Louver Panel		3A7482-01	1	1	1	1	1	1	1	1	
5	Control Module		SP-5212	1	1	1	-					
			4A5914G01				1	1	1	1	1	1
6	Deflector		3A9649-01							1	1	
7	Pilaster	CPT67	4A5583-01	8	8	8	8	8	8	8	8	
		CPT67-D2							4	4	4	
8	Shelf	CPT67	3A2830-12	4	4	4	4	4	4	4	4	
		CPT67-D2							2	2	2	
9	Shelf Clip	CPT67	4A5418-01	16	16	16	16	16	16	16	16	
		CPT67-D2							8	8	8	
10	Rail Cover (includes items 11, 12, and 13)		2A7060A01	1	1	1	1	-				
			2A8334A01					1	1	1	1	
11	Pivot Pin		4A4768-01	4	4	4	4	4	4	4	4	
12	Pivot Bolt		4A4769-01	4	4	4	4	4	4	4	4	
13	Handle		4A4518-01	1	1	1	1	1	1	1	1	
14	Pan Support Bracket		3A7687-02	2	2	2	2	2	2	2	2	
15	Right Upper Air Duct		1A2965-01	1	-							
			2A7798-01		1	1	1	1	1	1	-	
			2A8910-01									1
16	Center Upper Air Duct		1A2964-01	1	-							
			2A7800-01		1	1	1	1	1	1	-	
			2A8909-01									1
17	Left Upper Air Duct		1A2963-01	1	-							
			2A7799-01		1	1	1	1	1	1	-	
			2A8907-01									1
18	Right Rail Cover Bracket		4A5596-01	1	1	1	1	1	-	-	-	
			3A9236-01						1	1	1	
19	Left Rail Cover Bracket		4A5596-02	1	1	1	1	1	-	-	-	
			3A9236-02						1	1	1	
20	Cutting Board		3A4894-17	1	1	1	1	1	1	1	1	
21	Cutting Board Bracket		3A4890-01	2	2	2	2	2	2	2	2	



**A. Main Assembly**  
**CPT93(-D2)(-D4)(-D6)**  
 D-5 to H-7

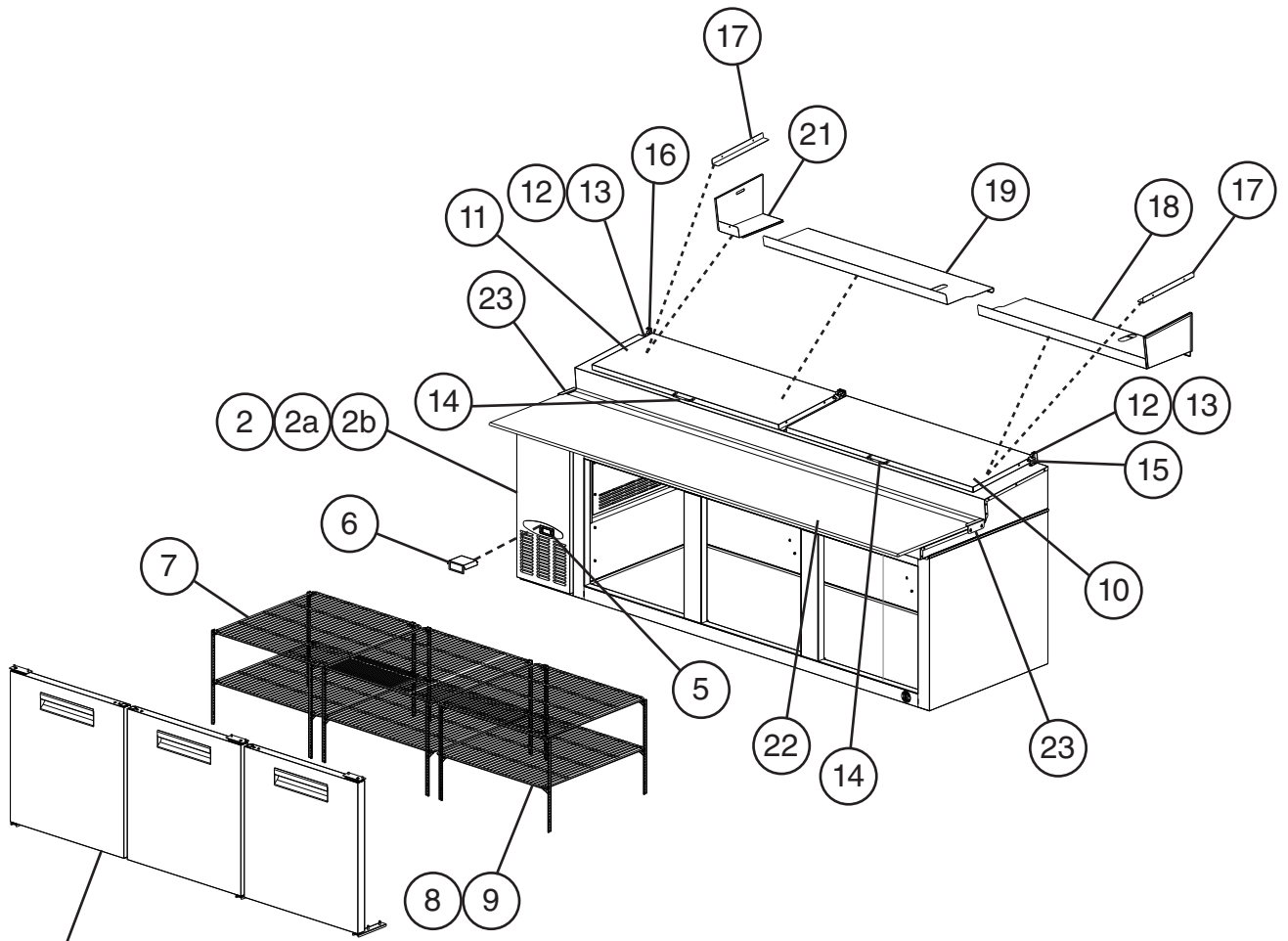

For Doors, see Sections "C" and "D"

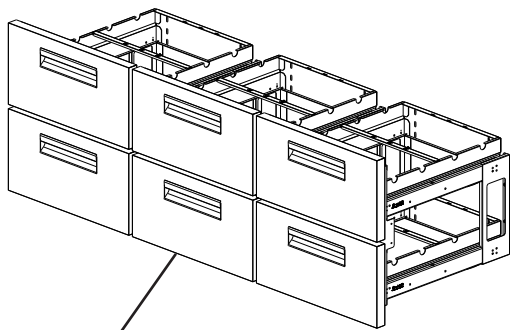

For Drawers, see Section "E"

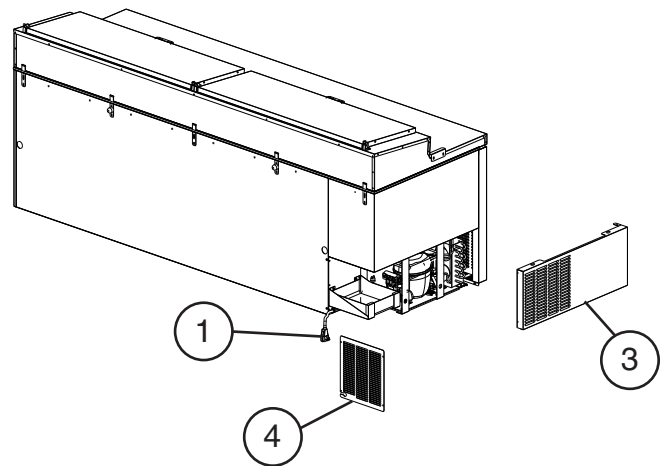

Title: A. Main Assembly Models: CPT93(-D2)(-D4)(-D6)													
Index No.	Description	Material or Model Number	Part Number	Required Number									
				D-5 to E-5	E-6 to F-5	F-6 F-7	G-5 G-6	G-7 to H-5	H-6 H-7				
1	Power Cord		4A2860-01	1	1	1	1	1	1				
2	Front Panel		2A8533-01	1	-	Auxiliary Code E-5 and earlier must also order SP-5168							
					1	1	1	1	1				
2a	Front Panel Latch		4A0508-03	4	2	2	2	2	2				
2b	Front Panel Striker		4A0515-01	4	2	2	2	2	2				
3	Left Side Panel		2A7066-01	1	-								
			2A7902-01		1	1	1	1	1				
4	Rear Louver Panel		3A7482-01	1	1	1	1	1	1				
5	Control Module		SP-5212	1	1	-							
			4A5914G01			1	1	1	1				
6	Deflector		3A9649-01					1	1				
7	Pilaster	CPT93	4A5583-01	12	12	12	12	12	12				
		CPT93-D2					8	8	8				
		CPT93-D4					4	4	4				
8	Shelf	CPT93	3A2830-12	6	6	6	6	6	6				
		CPT93-D2					4	4	4				
		CPT93-D4					2	2	2				
9	Shelf Clip	CPT93	4A5418-01	24	24	24	24	24	24				
		CPT93-D2					16	16	16				
		CPT93-D4					8	8	8				
10	Right Rail Cover (includes items 12, 13, and 14)		2A7023A01	1	1	1	-						
			2A8336A01				1	1	1				
11	Left Rail Cover (includes items 12, 13, and 14)		2A7025A01	1	1	1	-						
			2A8337A01				1	1	1				
12	Pivot Pin		4A4768-01	8	8	8	8	8	8				
13	Pivot Bolt		4A4769-01	8	8	8	8	8	8				
14	Handle		4A4518-01	2	2	2	2	2	2				
15	Right Rail Cover Bracket		4A5596-01	2	2	2	-						
			3A9236-01				2	2	2				
16	Left Rail Cover Bracket		4A5596-02	2	2	2	-						
			3A9236-02				2	2	2				
17	Pan Support Bracket		3A7687-01	2	2	2	2	2	2				
18	Right Upper Air Duct		1A2965-01	1	1	1	-						
			2A8108 -01				1	1	-				
			2A8915-01						1				
19	Right Center Upper Air Duct		1A3148-01	1	1	1	-						
	Center Upper Air Duct		2A8107-01				1	1	-				
			2A8914-01						1				
20	Left Center Upper Air Duct		1A2964-01	1	1	1	-						
21	Left Upper Air Duct		1A3141-01	1	1	1	-						
			2A7799-01				1	1	-				
			2A8907-01						1				
22	Cutting Board		3A4894-16	1	1	1	1	1	1				
23	Cutting Board Bracket		3A4890-01	2	2	2	2	2	2				

**B. Refrigeration Circuit**  
**CPT46(-D)**  
 D-5 to H-7

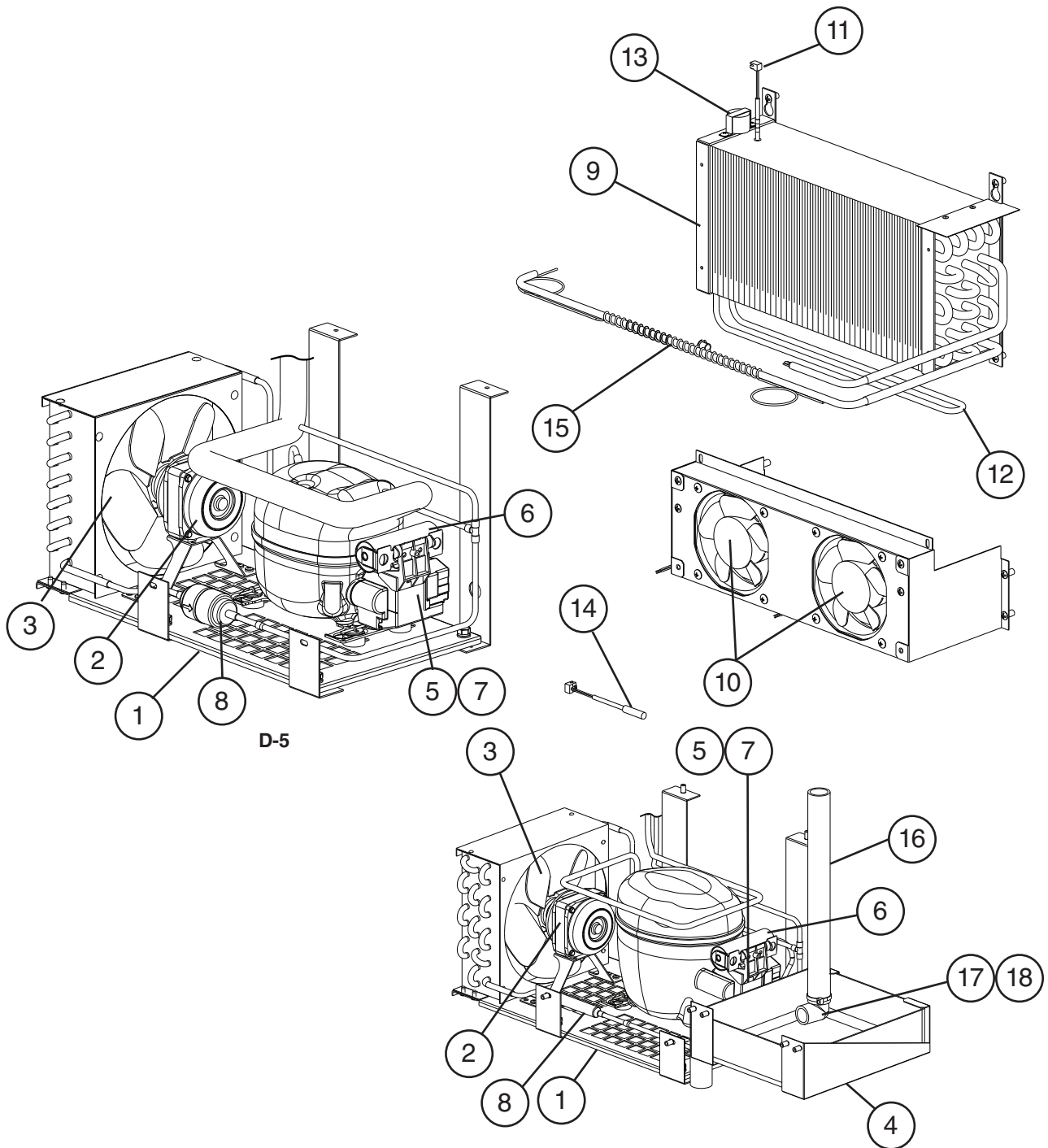

For compressor or condenser replacement, order item 1.

D-6 and Later

**Title: B. Refrigeration Circuit    Models: CPT46(-D)**

Index No.	Description	Material or Model Number	Part Number	Required Number									
				D-5 to G-5	G-6 to H-7								
1	Condensing Unit (includes compressor, condenser, and items 2 through 8; compressor and condenser are not sold individually)		3A8107-01	1	1								
2	Condenser Fan Motor		3A6798-01	1	1								
3	Condenser Fan Blade		3A6799-01	1	1								
4	Condensate Pan		1A3373-01	1	1								
5	Compressor External Protector		3A6774-01	1	1								
6	Start Capacitor		4A5525-01	1	1								
7	Start Relay		3A7232-01	1	1								
8	Drier		4A5576-01	1	1								
9	Evaporator		2A7531-01	1	1								
10	Evaporator Fan		4A5343-01	2	2								
11	Defrost Thermistor		4A4865-02	1	1								
12	Defrost Heater		3A6443-01	1	1								
13	Defrost Safety Thermostat		4A0954-02	1	1								
14	Cabinet Thermistor		4A4864-01	1	1								
15	Heat Exchanger		3A8228G01	1	1								
16	Drain Tube		4A0658L01	1	1								
17	Drain Boot		4A4938-01	1	-								
18	Drain Elbow		4A5624-01		1								

**B. Refrigeration Circuit**  
**CPT67(-D2)(-D4)**  
 C-5 to H-7

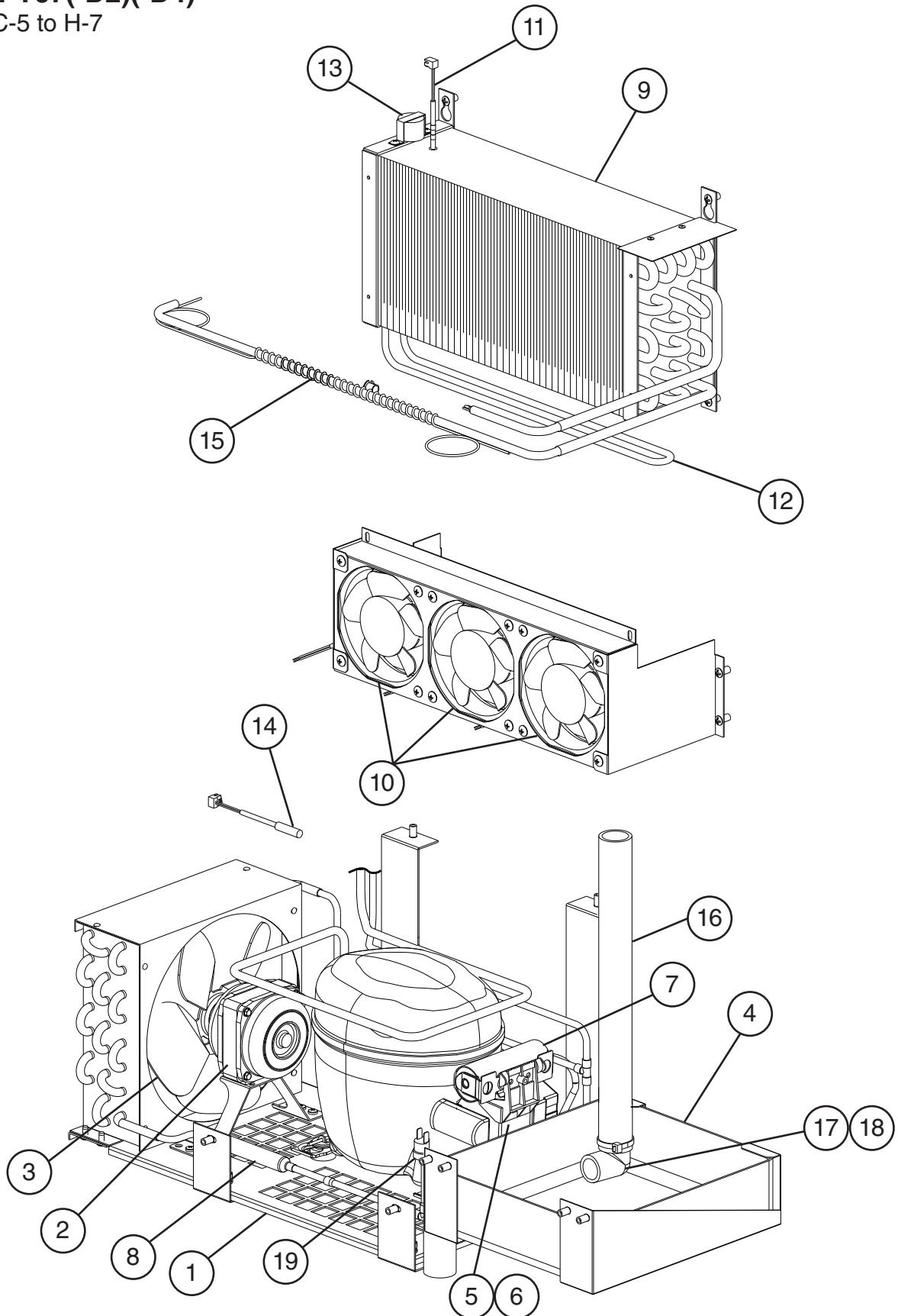

For compressor or condenser replacement, order item 1.

Title: B. Refrigeration Circuit Models: CPT67(-D2)(-D4)												
Index No.	Description	Material or Model Number	Part Number	Required Number								
				C-5 to G-5	G-6 to H-7							
1	Condensing Unit (includes compressor, condenser, and items 2 through 8; compressor and condenser are not sold individually)		3A8108-01	1	1							
2	Condenser Fan Motor		3A6798-01	1	1							
3	Condenser Fan Blade		3A6799-01	1	1							
4	Condensate Pan		1A3373-01	1	1							
5	Compressor External Protector		3A6936-01	1	1							
6	Start Relay		3A6937-01	1	1							
7	Start Capacitor		3A6938-01	1	1							
8	Drier		4A5576-01	1	1							
9	Evaporator		2A7531-01	1	1							
10	Evaporator Fan Motor		4A5343-01	3	3							
11	Defrost Thermistor		4A4865-02	1	1							
12	Defrost Heater		3A6443-01	1	1							
13	Defrost Safety Thermostat		4A0954-02	1	1							
14	Cabinet Thermistor		4A4864-01	1	1							
15	Heat Exchanger		SP-5251	1	1							
16	Drain Tube		4A0658L01	1	1							
17	Drain Boot		4A4938-01	1	-							
18	Drain Elbow		4A5624-01		1							
19	High-Pressure Switch		4A2516-01	1	1							

**B. Refrigeration Circuit**  
**CPT93(-D2)(-D4)(-D6)**  
D-5 to H-7

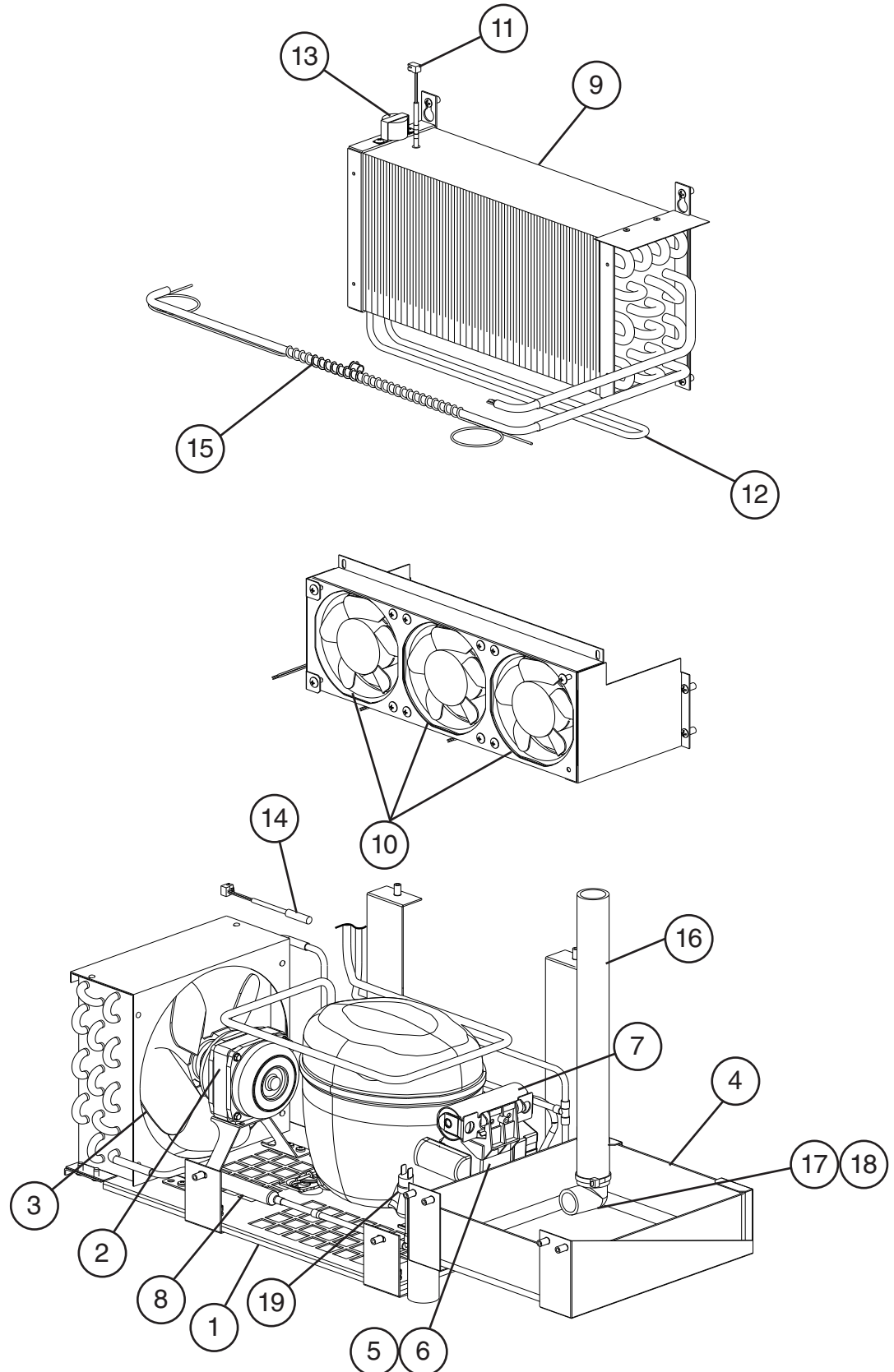

For compressor or condenser replacement, order item 1.

Title: B. Refrigeration Circuit    Models: CPT93(-D2)(-D4)(-D6)											
Index No.	Description	Material or Model Number	Part Number	Required Number							
				D-5 to G-5	G-6 to H-7						
1	Condensing Unit (includes compressor, condenser, and items 2 through 8; compressor and condenser are not sold individually)		3A8108-01	1	1						
2	Condenser Fan Motor		3A6798-01	1	1						
3	Condenser Fan Blade		3A6799-01	1	1						
4	Condensate Pan		1A3373-01	1	1						
5	Compressor External Protector		3A6936-01	1	1						
6	Start Relay		3A6937-01	1	1						
7	Start Capacitor		3A6938-01	1	1						
8	Drier		4A5576-01	1	1						
9	Evaporator		2A7531-01	1	1						
10	Evaporator Fan Motor		4A5343-01	3	3						
11	Defrost Thermistor		4A4865-02	1	1						
12	Defrost Heater		3A6443-01	1	1						
13	Defrost Safety Thermostat		4A0954-02	1	1						
14	Cabinet Thermistor		4A4864-01	1	1						
15	Heat Exchanger		SP-5251	1	1						
16	Drain Tube		4A0658L01	1	1						
17	Drain Boot		4A4938-01	1	-						
18	Drain Elbow		4A5624-01		1						
19	High-Pressure Switch		4A2516-01	1	1						



**C. Door-Right Hinged**  
**CPT46, CPT67(-D2), CPT93(-D2)(-D4)**  
 C-5 to H-7

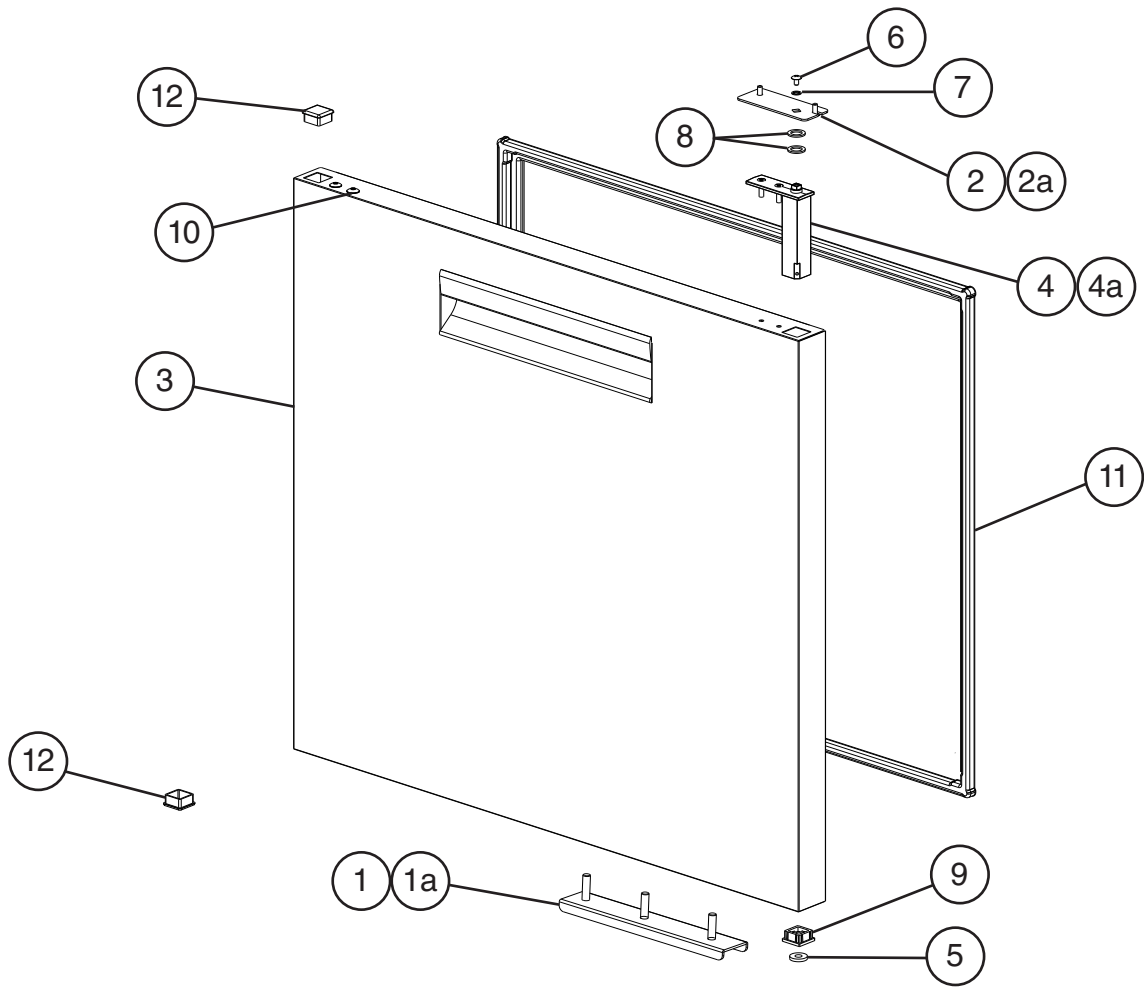

Title: C. Door-Right Hinged Models: CPT46, CPT67(-D2), CPT93(-D2)(-D4)						Required Number											
Index No.	Description	Material or Model Number	Part Number	C-5 to D-6 (D)	D-6 (E) to H-7												
1	Lower Hinge Bracket		3A6681G01	1	1												
1a	Hex Head Tapping Bolt		4A5213-01	2	2												
2	Upper Hinge Bracket		3A6810-01	1	1												
2a	Truss Head Screw	5x12, SS	7C32-0512	2	2												
3	Door Assembly (includes items 4 through 12)	<b>CPT46</b>	2A7328G01	1	1												
		<b>CPT67(-D2)</b>	2A6594G01	1	-												
		<b>CPT93(-D2)(-D4)</b>	2A7322G01			1											
4	Hinge Spring Cartridge (includes items 5 through 9)		3A9206-01	1	1												
4a	Countersunk Screw	5x20, SS	7C42-0520	2	2												
5	Thrust Washer		4A5234-01	1	1												
6	Screw		4A5230-01	1	1												
7	Lock Washer		4A5231-01	1	1												

Title: C. Door-Right Hinged Models: CPT46, CPT67(-D2), CPT93(-D2)(-D4)											
Index No.	Description	Material or Model Number	Part Number	Required Number							
				C-5 to D-6 (D)	D-6 (E) to H-7						
8	Thrust Washer		4A5233-01	2	2						
9	Bearing		4A5232-01	1	2						
10	Truss Head Screw (filler screws)	5x10	7C32-0510	2	2						
11	Gasket	CPT46	2A6996-09	1	1						
		CPT67(-D2)	2A5192-05	1	-						
		CPT93(-D2)(-D4)	2A6996-05		1						
12	End Cap		4A5432-01	2	2						

**D. Door-Left Hinged**  
**CPT67, CPT93**  
 C-5 to H-7

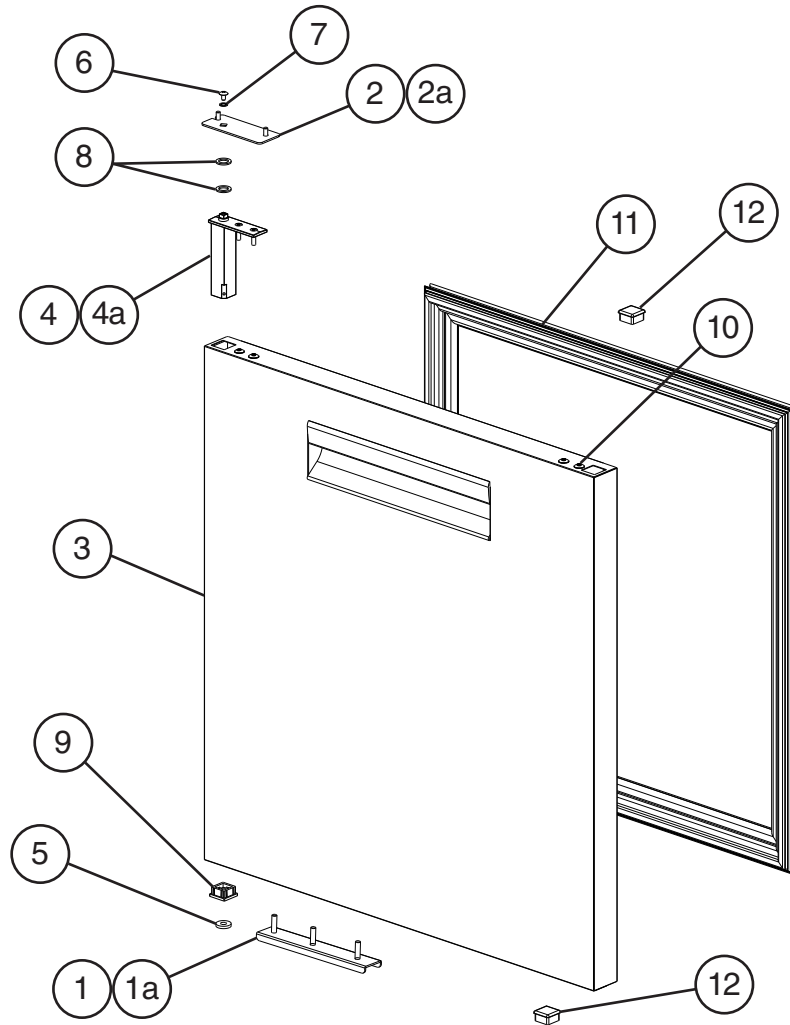

Title: D. Door-Left Hinged Models: CPT67, CPT93										
Index No.	Description	Material or Model Number	Part Number	Required Number						
				C-5 to D-6 (D)	D-6 (E) to H-7					
1	Lower Hinge Bracket		3A6681G01	1	1					
1a	Hex Head Tapping Bolt		4A5213-01	2	2					
2	Upper Hinge Bracket		3A6810-01	1	1					
2a	Truss Head Screw	5x12, SS	7C32-0512	2	2					
3	Door Assembly (includes items 4 through 12)		2A7031G01	1	-					
			2A7331G01		1					
4	Hinge Spring Cartridge (includes items 5 through 9)		3A9206-01	1	1					
4a	Countersunk Screw		7C42-0520	2	2					
5	Thrust Washer		4A5234-01	1	1					
6	Screw		4A5230-01	1	1					
7	Lock Washer		4A5231-01	1	1					

**Title: D. Door-Left Hinged    Models: CPT67, CPT93**

Index No.	Description	Material or Model Number	Part Number	Required Number								
				C-5 to D-6 (D)	D-6 (E) to H-7							
8	Thrust Washer		4A5233-01	2	2							
9	Bearing		4A5232-01	1	1							
10	Truss Head Screw (filler screws)		7C32-0510	2	2							
11	Gasket		2A5192-05	1	-							
			2A6996-05		1							
12	End Cap		4A5432-01	2	2							

**E. Drawer Assembly**  
**CPT46-D, CPT67-D2(-D4), CPT93-D2(-D4)(-D6)**  
 D-5 to H-7

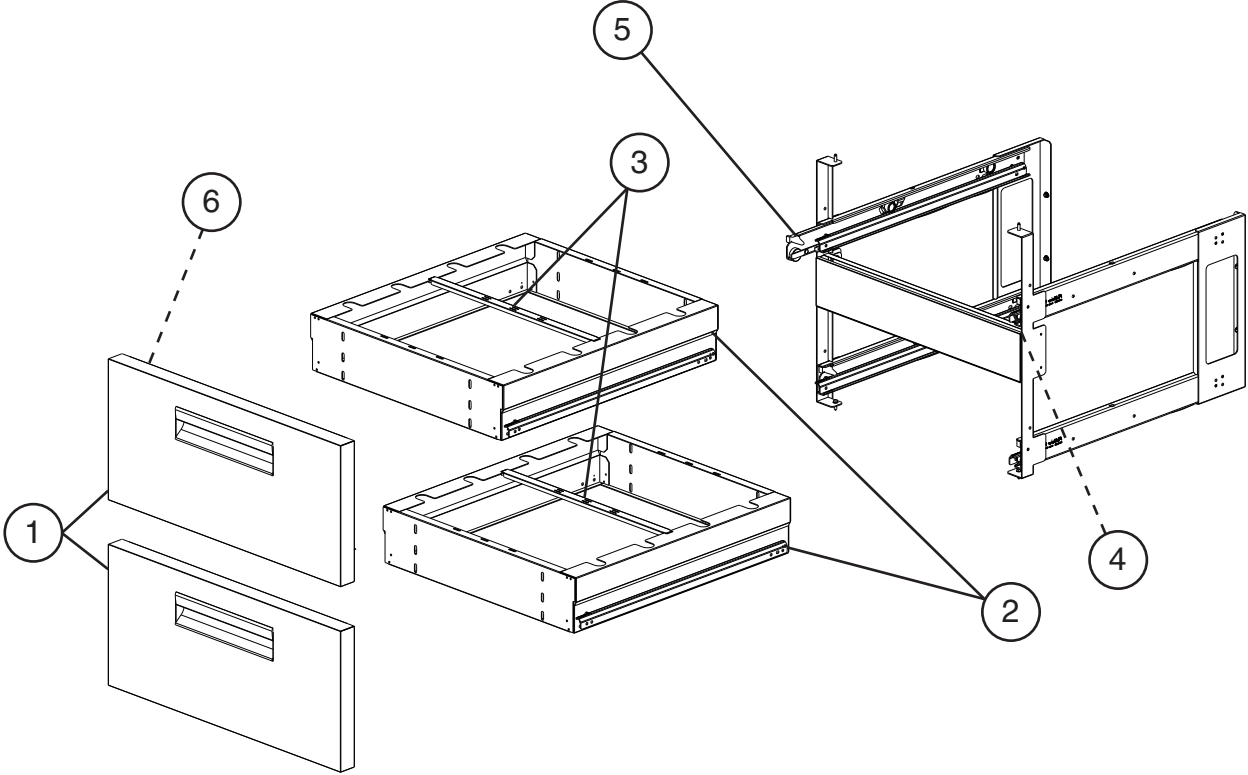

Title: E. Drawer Assembly    Models: CPT46-D, CPT67-D2(-D4), CPT93-D2(-D4)(-D6) Drawer Models											
Index No.	Description	Material or Model Number	Part Number	Required Number Per Section							
				D-5 to D-7	E-5 to H-7						
1	Drawer Face	<b>CPT46-D</b>	2A7235G01	2	-						
			2A7512G01		2						
		<b>CPT67-DX</b> <b>CPT93-DX</b>	2A7342G01	2	-						
			2A7510G01		2						
2	Drawer Box	<b>CPT46-D</b>	2A7236G01	2	2						
		<b>CPT67-DX</b> <b>CPT93-DX</b>	2A7319G01	2	2						
3	Drawer Divider		3B0029-02	2	2						
4	Right Side Roller		4A5674-02	2	2						
5	Left Side Roller		4A5674-05	2	2						
6	Drawer Gasket	<b>CPT46-D</b>	2A5192-16	2	2						
		<b>CPT67-DX</b> <b>CPT93-DX</b>	2A5192-15	2	2						

## F. Accessories & Labels

### CPT46(-D), CPT67(-D2)(-D4), CPT93(-D2)(-D4)(-D6)

C-5 to H-7

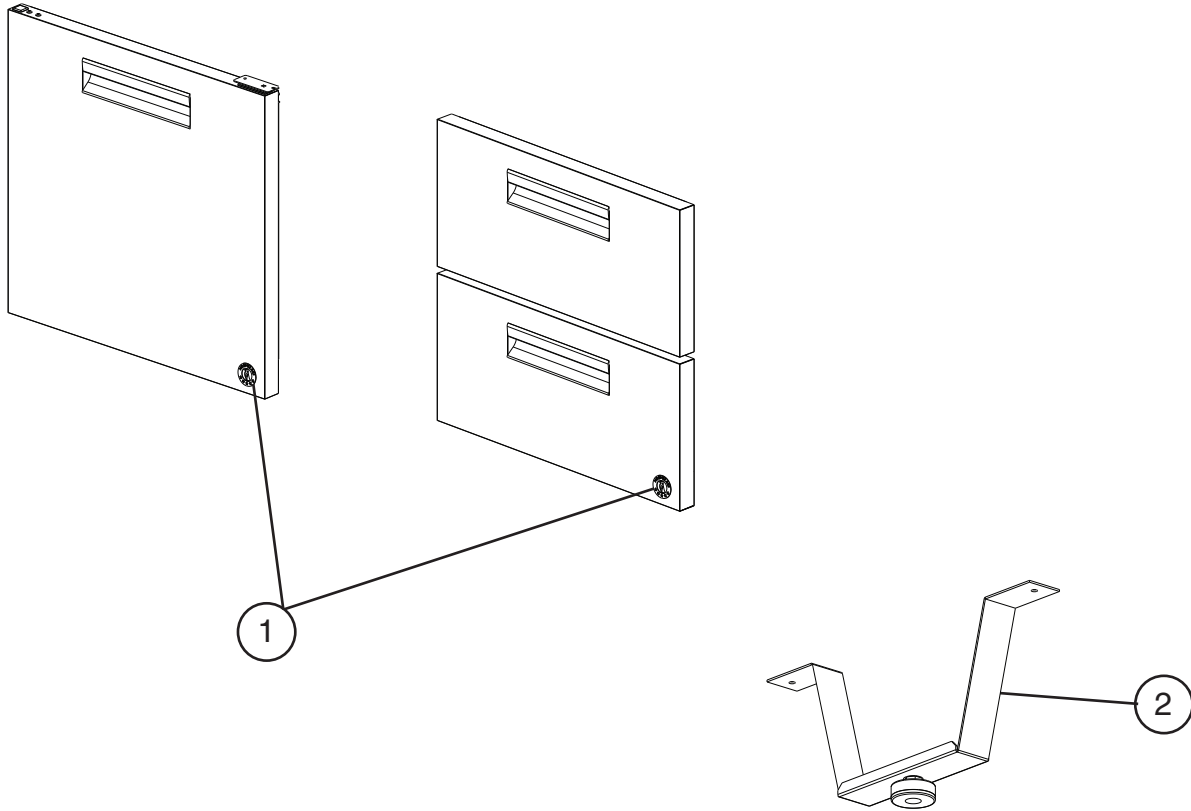

Title: F. Accessories & Labels Models: CPT46(-D), CPT67(-D2)(-D4), CPT93(-D2)(-D4)(-D6)					Required Number								
Index No.	Description	Material or Model Number	Part Number	C-5 to H-7									
1	Penguin Label		475552L01	1									
2	Anti-Tip Bracket	<b>CPT46(-D)</b>	3A8203A01	1									
3	6" Caster Kit (includes items 4 and 5)	<b>HS-5036</b>	4A5435A01	1									
4	6" Non-Locking Caster	<b>CPT46(-D)</b>	4A5428-01	2									
		<b>CPT67(-DX)</b>		3									
5	6" Locking Caster	<b>CPT46(-D)</b>	4A5428-02	2									
		<b>CPT67(-DX)</b>		3									
6	1/3 Size Pan, 4" Depth	<b>CPT46(-D)</b>	1000000351	6									
		<b>CPT67(-DX)</b>		9									
		<b>CPT93(-DX)</b>		12									
7	Pan Divider	<b>CPT46(-D)</b>	3A4934-01	6									
		<b>CPT67(-DX)</b>		9									
		<b>CPT93(-DX)</b>		12									