



# HOSHIZAKI

## Parts List

Commercial Series  
Refrigerated Kitchen Equipment

### Models

CR1B-FG/FGY/FS/HS

CF1B-FG/FGY/FS/HS

CR2B-FG/FGY/FS/HS

CF2B-FG/FGY/FS/HS

CR3B-FG/FGY/FS/HS

CF3B-FS/HS



[hoshizakiamerica.com](http://hoshizakiamerica.com)

Number: 71344  
Issued: 3-20-2012  
Revised: 8-29-2017

## CONTENTS

Auxiliary Codes.....	3
Note About Ordering Parts .....	5
A. Main Assembly .....	6
CR1B-FG/FGY/FS/HS, CF1B-FG/FGY/FS/HS .....	6
CR2B-FG/FGY/FS/HS, CF2B-FG/FGY/FS/HS .....	8
CR3B-FG/FGY/FS/HS, CF3B-FS/HS.....	10
B. Refrigeration Circuit.....	13
CR1B-FG/FGY/FS/HS, CR3B-FG/FGY/FS/HS.....	13
CF1B-FG/FGY/FS/HS, CF3B-FS/HS.....	15
CR2B-FG/FGY/FS/HS, CR3B-FG/FGY/FS/HS.....	17
CF2B-FG/FGY/FS/HS, CF3B-FS/HS.....	19
C. Control Box Assembly .....	21
CR1B-FG/FGY/FS/HS, CF1B-FG/FS/HS, CR2B-FG/FGY/FS/HS,.....	21
CR3B-FG/FGY/FS/HS, CF3B-FS/HS(One Section) .....	21
CF2B-FG/FGY/FS/HS, CF3B-FS/HS(Two Section) .....	22
D. Door-Right Hinged.....	23
Full Glass: CR1B-FG, CF1B-FG, CR2B-FG, CF2B-FG, CR3B-FG.....	23
Full Glass: CR1B-FGY, CF1B-FGY, CR2B-FGY, CF2B-FGY, CR3B-FGY.....	24
Full Solid: CR1B-FS, CF1B-FS, CR2B-FS, CF2B-FS, CR3B-FS, CF3B-FS .....	25
Half Solid: CR1B-HS, CF1B-HS, CR2B-HS, CF2B-HS, CR3B-HS, CF3B-HS.....	26
E. Door-Left Hinged .....	28
Full Glass: CR2B-FG, CF2B-FG, CR3B-FG.....	28
Full Glass: CR2B-FGY, CF2B-FGY, CR3B-FGY.....	29
Full Solid: CR2B-FS, CF2B-FS, CR3B-FS, CF3B-FS .....	30
Half Solid: CR2B-HS, CF2B-HS, CR3B-HS, CF3B-HS.....	31
F. Accessories & Labels.....	33

## Auxiliary Codes

### CR1B-FG

A-5 September 2011  
B-5 January 2012  
B-6 May 2012  
C-5 January 2013  
D-5 February 2014  
D-6 March 2014  
D-7 July 2014

### CR1B-FGY

D-5 June 2014  
D-7 July 2014  
D-8 September 2014  
E-5 January 2015  
E-7 June 2015

### CR1B-FS

V-5 December 2010  
A-5 February 2011  
B-5 January 2012  
B-6 May 2012  
C-5 January 2013  
D-5 February 2014  
D-6 March 2014  
D-7 July 2014  
D-8 September 2014  
E-5 January 2015  
E-7 July 2015

### CR1B-HS

A-5 February 2011  
B-5 January 2012  
B-6 May 2012  
C-5 January 2013  
C-6 October 2013  
D-6 March 2014  
D-7 July 2014  
D-8 September 2014  
E-5 January 2015  
E-7 June 2015

### CF1B-FG

B-5 January 2012  
B-6 May 2012  
C-5 January 2013  
C-6 June 2014  
D-5 February 2014  
D-6 March 2014  
D-7 July 2014  
D-8 September 2014

### CF1B-FGY

D-7 July 2014

### CF1B-FS

A-5 January 2011  
B-5 January 2012  
B-6 May 2012  
C-5 January 2013  
D-5 January 2014  
D-6 March 2014  
D-7 July 2014  
D-8 September 2014  
D-9 October 2014  
E-5 January 2015

### CF1B-HS

A-5 February 2011  
B-5 February 2012  
B-6 May 2012  
C-5 January 2013  
C-6 October 2013  
D-5 January 2014  
D-6 March 2014  
D-7 July 2014  
D-8 September 2014  
D-9 October 2014  
E-5 January 2015  
E-6 May 2015  
E-7 June 2015

### CR2B-FG

A-5 October 2011  
B-6 May 2012  
C-5 January 2013  
D-5 February 2014

### CR2B-FGY

D-5 June 2014  
D-7 July 2014  
D-8 September 2014  
E-5 January 2015  
E-7 June 2015

### CR2B-FS

V-5 December 2010  
A-5 February 2011  
B-5 January 2012  
B-6 May 2012  
C-5 January 2013  
D-5 February 2014  
D-6 March 2014  
D-7 July 2014  
D-8 September 2014  
E-5 January 2015

### CR2B-HS

A-5 February 2011  
B-5 January 2012  
B-6 May 2012  
C-5 January 2013  
D-7 July 2014

### CF2B-FG

B-5 August 2012  
C-5 March 2013  
D-7 July 2014

### CF2B-FGY

D-7 August 2014

### CF2B-FS

V-6 December 2010  
A-5 January 2011  
B-5 January 2012  
B-6 May 2012  
C-5 January 2013  
D-5 February 2014  
D-7 July 2014  
D-8 September 2014  
D-9 October 2014  
E-5 January 2015

**CF2B-HS**

A-5 February 2011  
B-6 May 2012  
C-5 January 2013  
D-5 January 2014  
D-6 June 2014  
D-7 July 2014  
D-8 September 2014  
D-9 November 2014

**CR3B-FG**

C-5 August 2013  
D-5 January 2014

**CR3B-FGY**

D-5 June 2014  
D-6 July 2014  
D-8 September 2014  
E-5 January 2015  
E-7 June 2015

**CR3B-FS**

A-5 February 2011  
B-5 January 2012  
B-6 May 2012  
C-5 January 2013  
D-5 January 2014  
D-6 May 2014  
D-7 July 2014  
D-8 October 2014

**CR3B-HS**

A-5 March 2011  
B-5 April 2012  
B-6 May 2012  
C-5 July 2013  
D-6 June 2014  
D-7 September 2014

**CF3B-FS**

A-5 January 2011  
B-5 January 2012  
B-6 May 2012  
D-5 February 2014  
D-6 June 2014  
D-7 August 2014  
D-8 September 2014  
D-9 November 2014  
E-5 January 2015

**CF3B-HS**

B-6 May 2012  
C-5 June 2012  
D-6 June 2014  
D-7 September 2014  
D-8 November 2014

## Beginning Serial Numbers for Control Module Change

CR1B-FG	B50031B	CR2B-FG	B6 and later	CR3B-HS	B50001D
CR1B-FS	B50602B	CR2B-FS	B50722C	CF3B-FS	B50053B
CR1B-HS	B50046B	CR2B-HS	B50011B	CF3B-HS	B6 and later
CF1B-FG	B50004D	CF2B-FS	B50642B		
CF1B-FS	B50482C	CF2B-HS	B6 and later		
CF1B-HS	B50101B	CR3B-FS	B50082C		

### Auxiliary Code Breakdown

The auxiliary code is the first two characters in the serial number. The first character indicates the year. Years progress or regress in alphabetical order. The series runs from "A" through "V" and the letters "I" and "O" are skipped. The second character indicates significant part changes within a year. Base is "5" and this number advances for each change. In cases where there is a letter in parentheses, this designates the month. This is the last character in the serial number. The series runs from "(A)" through "(M)" and the letter "(I)" is skipped. This designation is only included when identifying a parts change within an auxiliary code.

### Note About Ordering Parts

Most assemblies cannot be ordered as complete units; parts in the assemblies generally must be ordered separately.

**A. Main Assembly**  
**CR1B-FG/FGY/FS/HS, CF1B-FG/FGY/FS/HS**  
 V-5 to E-7

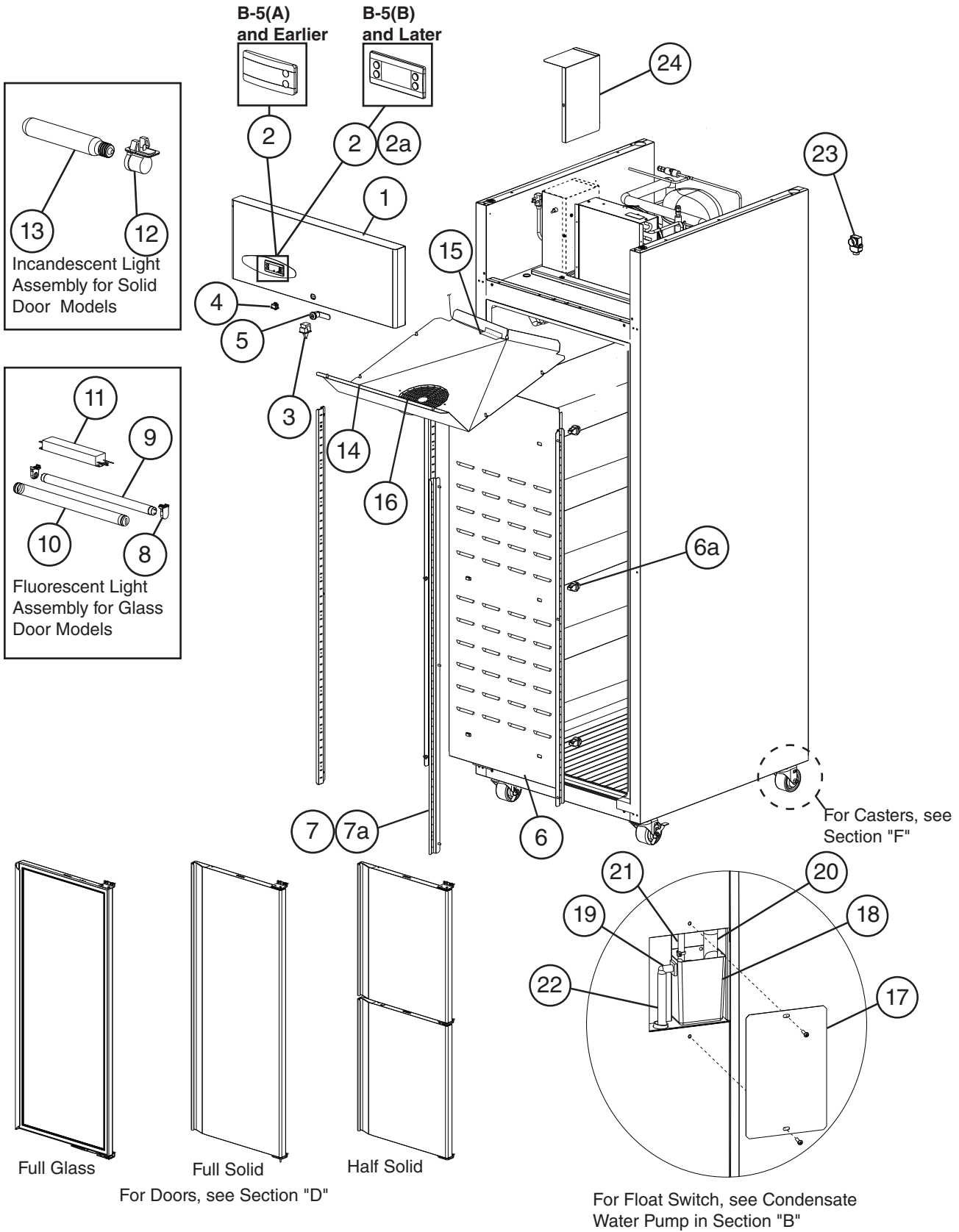

Title: A. Main Assembly Model: CR1B-FG/FGY/FS/HS, CF1B-FG/FGY/FS/HS											
Index No.	Description	Material or Model Number	Part Number	Required Number							
				V-5 to A-5 (F)	A-5 (G) to B-5 (A)	B-5 (B) to B-6 (E)	B-6 (F)	C-5 to D-8	D-9 to E-7		
1	Front Panel	<b>CR1B-FG/FGY</b> <b>CF1B-FG/FGY</b>	2A6705-01	1	1	1	1	-			
			2A7072-01					1	1		
		<b>CR1B-FS/HS</b> <b>CF1B-FS/HS</b>	2A5219-01	1	1	1	1	-			
			2A7072-01					1	1		
2	Display Module (includes mounting clips)		4A4862-01	1	1	See Page 5 for Exact Beginning Serial Numbers for Control Module Change					
	Control Module	<b>CR1B-FG/FGY/FS/HS</b>	4A5500G01	See "C. Control Box Assembly" for Control Module		1	1	1	1		
		<b>CF1B-FG/FGY/FS/HS</b>	4A5501G01			1	1	1	1		
2a	Control Module Mounting Clip		4A5502-01			2	2	2	2		
3	Door Switch		3A1826-01	1	1	1	1	1	1		
4	Fluorescent Light Switch	<b>CR1B-FG/FGY</b> <b>CF1B-FG/FGY</b>	4A0418-01	1	1	1	1	1	1		
5	Lock (includes 2 keys)		4A4924-01	1	1	1	1	1	1		
6	Rear Duct Panel		2A5205-01	1	1	1	1	1	1		
6a	Duct Stand Off		4A4874-01	6	6	6	6	6	6		
7	Pilaster		3A0145-02	4	4	4	4	4	4		
7a	Truss Head Screw	5x10, SS	7C32-0510	12	12	12	12	12	12		
8	Fluorescent Light Mount	<b>CR1B-FG/FGY</b> <b>CF1B-FG/FGY</b>	4A4346-01	2	2	2	2	2	2		
9	Fluorescent Light Bulb		4A4347-02	1	1	1	1	1	1		
10	Fluorescent Light Bulb Guard		4A4348-02	1	1	1	1	1	1		
11	Fluorescent Light Ballast		4A4350-01	1	1	1	1	1	1		
12	Incandescent Light Socket	<b>CR1B-FS/HS</b> <b>CF1B-FS/HS</b>	4A4443-01	1	1	1	1	1	1		
13	Incandescent Light Bulb		4A4444-01	1	1	1	1	1	1		
14	Evaporator Fan Shroud		3A6446G01	1	1	1	1	1	1		
15	Drain Tube Heater	<b>CF1B-FG/FGY/FS/HS</b>	4A2975-05		1	1	1	1	-		
			4A2975-07						1		
16	Evaporator Fan Guard		4A4860-01	1	1	1	1	1	1		
17	Reservoir Cover		3A5898-01	1	1	1	1	1	1		
18	Drain Reservoir		3A5565-01	1	1	1	1	1	1		
19	Drain Fitting		4A2792-01	1	1	1	1	1	1		
20	Drain Boot		4A4938-01	1	1	1	1	1	1		
21	PVC Tubing	L=650 mm	771611438	1	1	1	1	1	1		
22	Silicone Hose	L=150 mm	773013812	1	1	1	1	1	1		
23	Pressure Relief Valve	<b>CF1B-FGY/FS/HS</b>	4A5694-01						1		
24	Control Box Cover		2A5209-01	1	1	1	-				
			2A6750-01				1	1	1		

**A. Main Assembly**  
**CR2B-FG/FGY/FS/HS, CF2B-FG/FGY/FS/HS**  
 V-5 to E-7

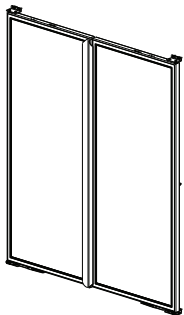
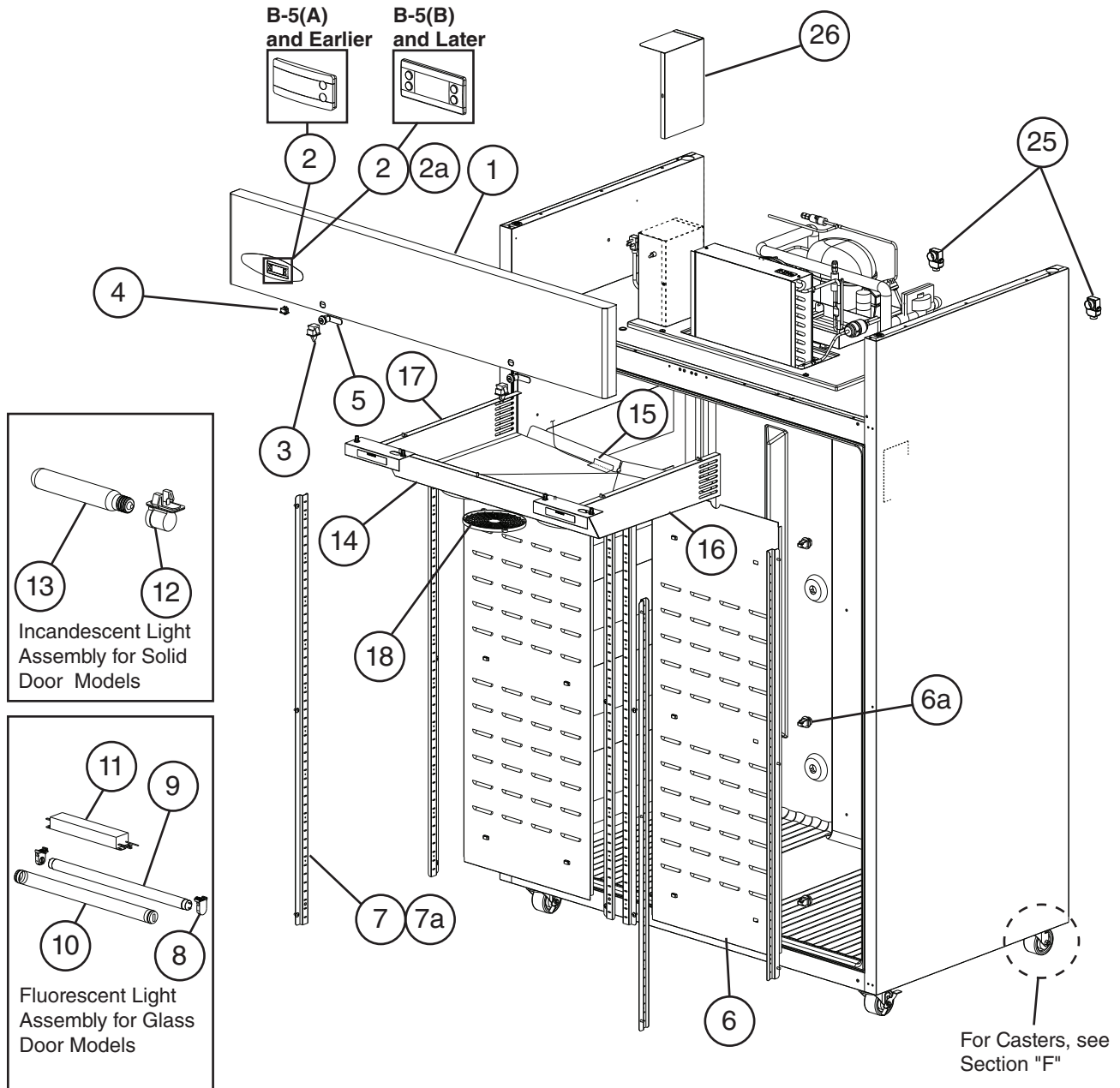

Full Glass

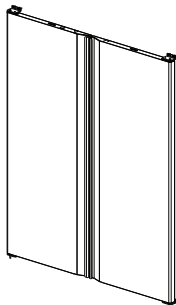

Full Solid

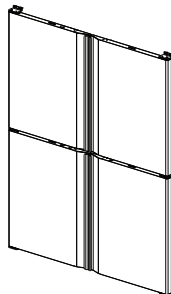

Half Solid

For Doors, see Sections "D" and "E"

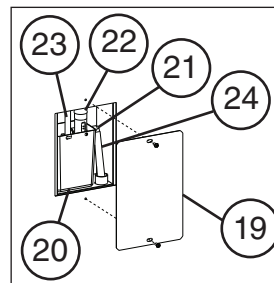

For Float Switch, see Condensate Water Pump in Section "B"



Title: A. Main Assembly Model: CR2B-FG/FGY/FS/HS, CF2B-FG/FGY/FS/HS												
Index No.	Description	Material or Model Number	Part Number	Required Number								
				V-5 to A-5 (F)	A-5 (G) to B-5 (A)	B-5 (B) to B-6 (E)	B-6 (F)	C-5 to D-8	D-9 to E-7			
1	Front Panel	CR2B-FG/FGY	2A6706-01		1	1	1	-				
			2A7073-01				1	1				
		CR2B-FS/HS CF2B-FS/HS	2A5884-01	1	1	1	1	-				
			2A7073-01					1	1			
2	Display Module (includes mounting clips)		4A4862-01	1	1	See Page 5 for Exact Beginning Serial Numbers for Control Module Change						
	Control Module	CR2B-FG/FGY/FS/HS	4A5500G01	See "C. Control Box Assembly" for Control Module		1	1	1	1			
		CF2B-FG/FGY/FS/HS	4A5501G01			1	1	1	1			
2a	Control Module Mounting Clip		4A5502-01			2	2	2	2	2	2	
3	Door Switch		3A1826-01	2	2	2	2	2	2			
4	Fluorescent Light Switch	CR2B-FG/FGY CF2B-FG/FGY	4A0418-01	1	1	1	1	1	1			
5	Lock (includes 2 keys)		4A4924-01	2	2	2	2	2	2			
6	Rear Duct Panel		2A5205-01	2	2	2	2	2	2			
6a	Duct Stand Off		4A4874-01	12	12	12	12	12	12			
7	Pilaster		3A0145-02	8	8	8	8	8	8			
7a	Truss Head Screw	5x10, SS	7C32-0510	24	24	24	24	24	24			
8	Fluorescent Light Mount	CR2B-FG/FGY CF2B-FG/FGY	4A4346-01	4	4	4	4	4	4			
9	Fluorescent Light Bulb		4A4347-02	2	2	2	2	2	2			
10	Fluorescent Light Bulb Guard		4A4348-02	2	2	2	2	2	2			
11	Fluorescent Light Ballast		4A4350-01	1	1	1	1	1	1			
12	Incandescent Light Socket	CR2B-FS/HS CF2B-FS/HS	4A4443-01	2	2	2	1	2	2			
13	Incandescent Light Bulb		4A4444-01	2	2	2	1	2	2			
14	Evaporator Fan Shroud		3A6212G01	1	1	1	1	1	1			
15	Drain Tube Heater	CF2B-FG/FGY/FS/HS	4A2975-05		1	1	1	1	-			
			4A2975-07						1			
16	Right Evaporator Fan Shroud Side		3A6629G01	1	1	1	1	1	1			
17	Left Evaporator Fan Shroud Side		3A6638G01	1	1	1	1	1	1			
18	Evaporator Fan Guard		4A4860-01	3	3	3	3	3	3			
19	Reservoir Cover		3A5898-01	1	1	1	3	1	1			
20	Drain Reservoir		3A5565-01	1	1	1	3	1	1			
21	Drain Fitting		4A2792-01	1	1	1	3	1	1			
22	Drain Boot		4A4938-01	1	1	1	1	1	1			
23	PVC Tubing	L=860 mm	771611438	1	1	1	1	1	1			
24	Silicone Hose	L=150 mm	773013812	1	1	1	1	1	1			
25	Pressure Relief Valve	CF2B-FGY/FS/HS	4A5694-01							2		
26	Control Box Cover	CR2B-FG/FGY/FS/HS	2A5209-01	1	1	1	-					
			2A6750-01				1	1	1			
		CF2B-FS/HS	2A6176-01	1	1	1	-					
			2A6751-01					1	1	1		



Title: A. Main Assembly Model: CR3B-FG/FGY/FS/HS, CF3B-FS/HS													
Index No.	Description	Material or Model Number	Part Number	Required Number									
				A-5 (A-F)	A-5 (G) to B-5 (A)	B-5 (B) to B-6 (E)	B-6 (F) to D-8	D-9 to E-7					
1	Front Panel	CR3B-FG/FGY	2A6416-01	1	1	-							
			2A7074-01			1	1	1					
		CR3B-FS/HS CF3B-FS/HS	2A6416-01	1	1	-							
			2A7074-01			1	1	1					
2	Display Module (includes mounting clips)		4A4862-01	2	2	See Page 5 for Exact Beginning Serial Numbers for Control Module Change							
	Control Module	CR3B-FG/FGY/FS/HS	4A5500G01	See "C. Control Box Assembly" for Control Module	2	2							
		CF3B-FS/HS	4A5501G01		2	2							
2a	Control Module Mounting Clip		4A5502-01		4	4	4						
3	Door Switch		3A1826-01	3	3	3	3	3					
4	Flourescent Light Switch	CR3B-FG/FGY	4A0418-01		2	2	2	2					
5	Lock (includes 2 keys)		4A4924-01	3	3	3	3	3					
6	Rear Duct Panel		2A5205-01	3	3	3	3	3					
6a	Duct Stand Off		4A4874-01	18	18	18	18	18					
7	Pilaster		3A0145-02	12	12	12	12	12					
7a	Truss Head Screw	5x10, SS	7C32-0510	36	36	36	36	36					
8	Flourescent Light Mount	CR3B-FG/FGY	4A4346-01	2	2	2	2	2					
9	Flourescent Light Bulb		4A4347-02	1	1	1	1	1					
10	Flourescent Light Bulb Guard		4A4348-02	1	1	1	1	1					
11	Flourescent Light Ballast		4A4350-01	1	1	1	1	1					
12	Incandescent Light Socket		CR3B-FS/HS	4A4443-01	3	3	3	3	3				
13	Incandescent Light Bulb		4A4444-01	3	3	3	3	3					
14	Evaporator Fan Shroud	One Section	3A6446G01	1	1	1	1	1					
		Two Section	3A6212G01	1	1	1	1	1					
15	Drain Tube Heater	CF3B-FS/HS	4A2975-05		2	2	2	-					
			4A2975-07					2					
16	Right Evaporator Fan Shroud Side		3A6629G01	1	1	1	1	1					
17	Left Evaporator Fan Shroud Side		3A6638G01	1	1	1	1	1					
18	Evaporator Fan Guard		4A4860-01	4	4	4	4	1					
19	Reservoir Cover		3A5898-01	2	2	2	2	2					
20	Drain Reservoir		3A5565-01	2	2	2	2	2					
21	Drain Fitting		4A2792-01	2	2	2	2	2					
22	Drain Boot		4A4938-01	2	2	2	2	2					
23	PVC Tubing	One Section, L=650 mm	771611438	1	1	1	1	1					
		Two Section, L=860 mm	771611438	1	1	1	1	1					
24	Silicone Hose	L=150 mm	773013812	2	2	2	2	2					
25	Power Cord	CR3B-FG/FGY/FS/HS	4A5379-01	1	1	1	1	1					
		CF3B-FS/HS	4A5318-01	1	1	1	1	1					
26	Pressure Relief Valve	CF3B-FS/HS	4A5694-01					3					

Title: A. Main Assembly Model: CR3B-FG/FGY/FS/HS, CF3B-FS/HS												
Index No.	Description	Material or Model Number	Part Number	Required Number								
				A-5 (A-F)	A-5 (G) to B-5 (A)	B-5 (B) to B-6 (E)	B-6 (F) to D-8	D-9 to E-7				
27	Control Box Cover	<b>CR3B-FG/FGY/FS/HS</b>	2A5209-01	2	2	2	-					
			2A6750-01				2	2				
		<b>CF3B-FS/HS</b> (One Section)	2A5209-01	1	1	1	-					
			2A6750-01				1	1				
28	Control Box Cover	<b>CF3B-FS/HS</b> (Two Section)	2A6176-01	1	1	1	-					
			2A6751-01				1	1				

**B. Refrigeration Circuit**  
**CR1B-FG/FGY/FS/HS, CR3B-FG/FGY/FS/HS**  
 V-5 to E-7

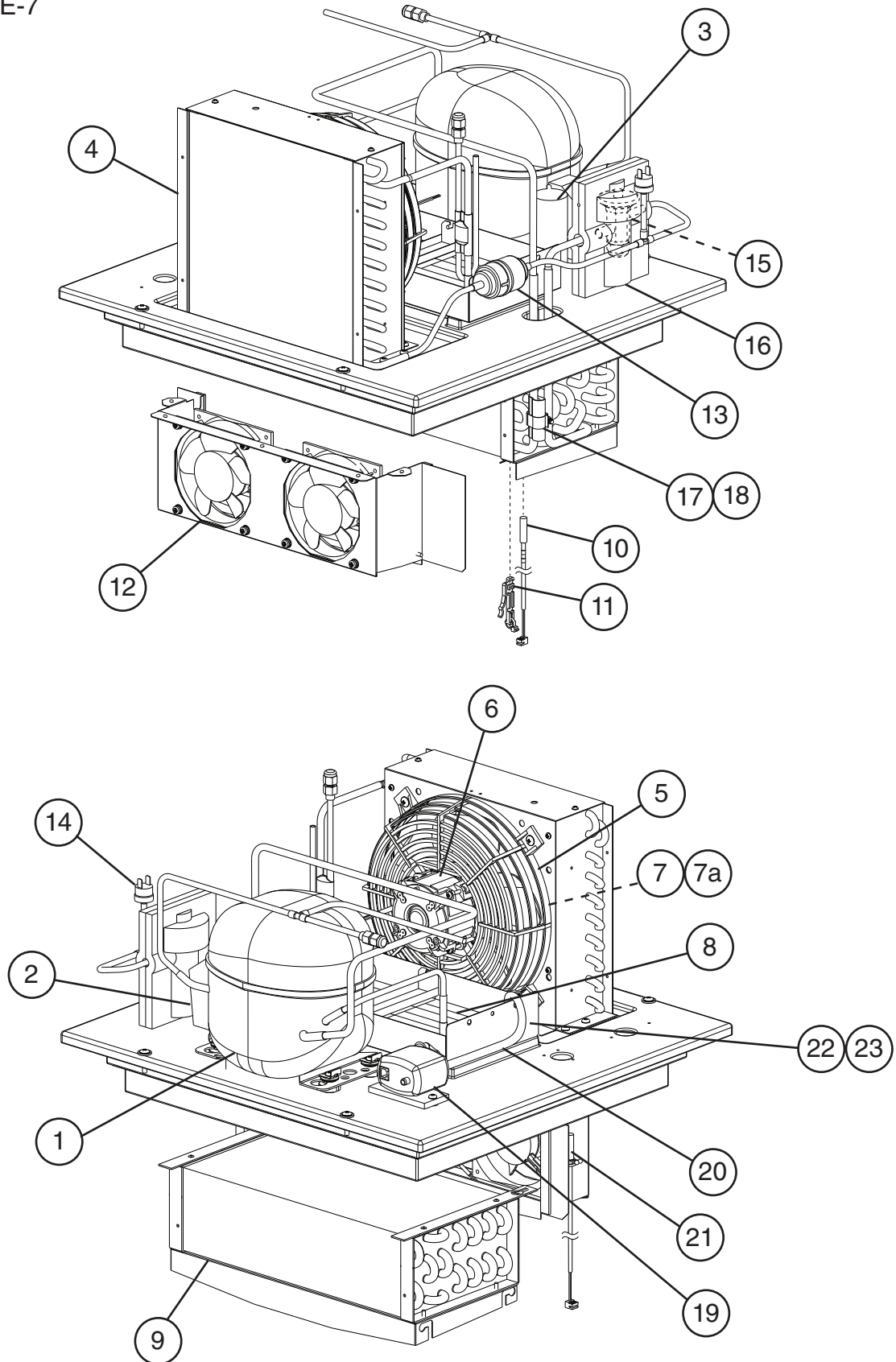

Title: B. Refrigeration Circuit Model: CR1B-FG/FGY/FS/HS, CR3B-FG/FGY/FS/HS												
Index No.	Description	Material or Model Number	Part Number	Required Number								
				V-5 to A-5 (G)	A-5 (H) to B-5 (A)	B-5 (B) to B-5 (G)	B-5 (H) to D-7	D-8 to E-7				
1	Compressor		4A3177-01	1	1	1	1	1				
2	Start Relay		4A2135-03	1	1	1	1	1				
3	Start Capacitor	280MFD, 125/165VAC	4A2134-01	1	1	1	1	1				
4	Condenser		2A6415-01	1	1	1	1	1				
5	Condenser Fan Guard		2A5187-01	1	1	1	1	1				
6	Condenser Fan Motor		4A4869-01	1	1	-						
			4A5498-01			1	1	1				
7	Condenser Fan Blade		3A5817-01	1	1	1	1	1				
7a	Washer		3A6852-01		1	1	1	-				
8	Condensate Tubing		3A6465G01	1	1	1	1	1				
9	Evaporator		2A6463-01	1	1	1	1	1				
10	Defrost Thermistor		4A4865-02	1	1	1	1	1				
11	Thermistor Clip		4A3248G01	1	1	1	1	1				
12	Evaporator Fan		4A5343-01	2	2	2	2	2				
13	Drier		4A1113-01	1	1	1	1	1				
14	High-Pressure Switch		4A2516-01	1	1	1	1	1				
15	Thermostatic Expansion Valve		4A4597-01	1	1	1	1	1				
16	Thermostatic Expansion Valve Cover		4A4646-01	1	1	1	1	1				
17	Thermostatic Expansion Valve Bulb Holder		3A0107-01	1	1	1	1	1				
18	Clamp		443461-01	1	1	1	1	1				
19	Condensate Water Pump (includes float switch)		SP-5080	1	1	1	-					
			4A5546-01				1	1				
20	PVC Tubing	L=350 mm	771611438	1	1	1	1	1				
21	Cabinet Thermistor		4A4864-01	1	1	1	1	1				
22	Condensate Pan		2A7315-01	1	1	1	1	1				
23	Condensate Pan Strap		3A8245-01	1	1	1	1	1				

# B. Refrigeration Circuit

## CF1B-FG/FGY/FS/HS, CF3B-FS/HS

A-5 to E-7

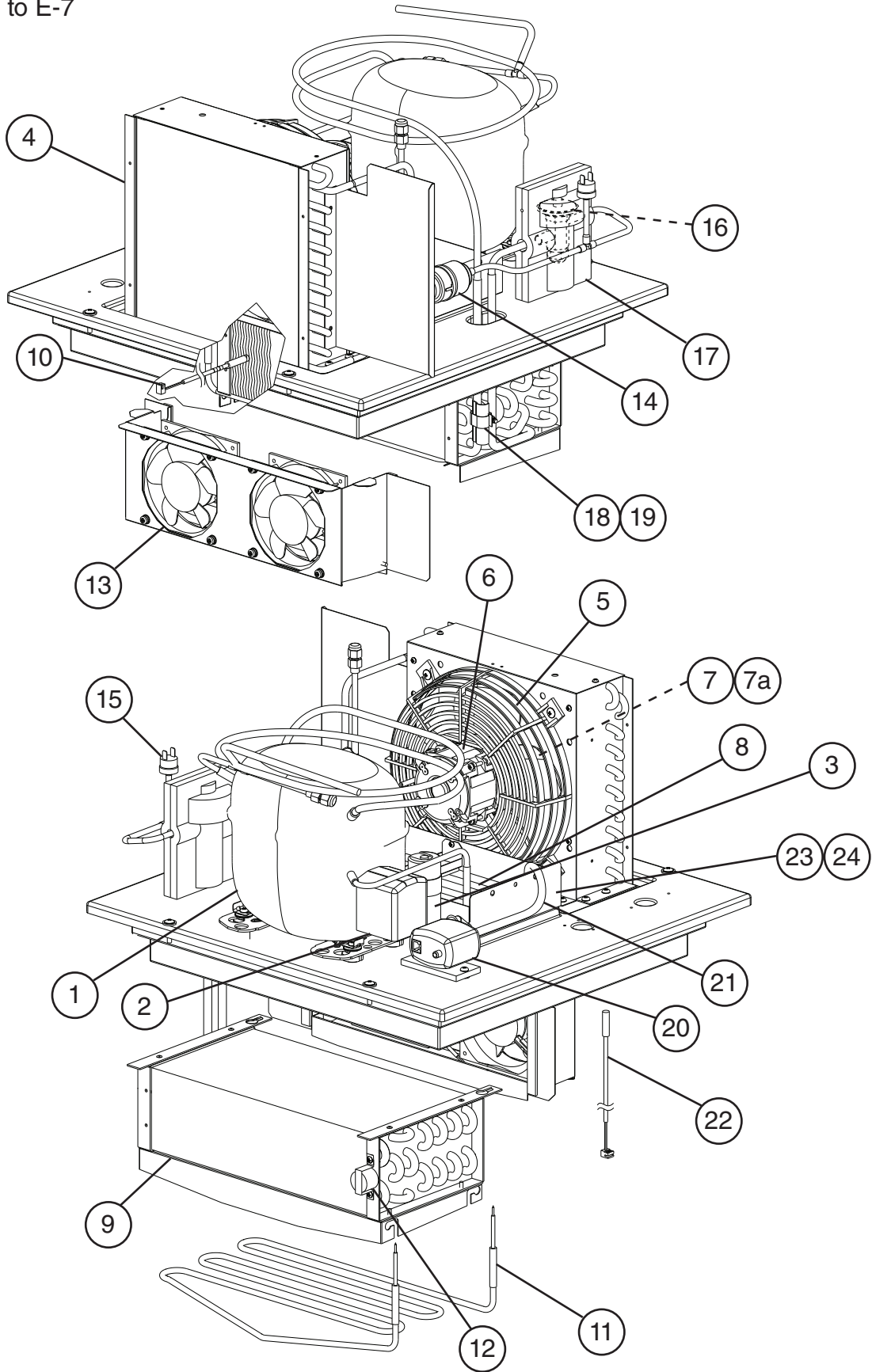

**Title: B. Refrigeration Circuit Model: CF1B-FG/FGY/FS/HS, CF3B-FS/HS**

Index No.	Description	Material or Model Number	Part Number	Required Number											
				A-5 (A-G)	A-5 (H) to B-5 (A)	B-5 (B) to B-5 (G)	B-5 (H) to D-7	D-8	D-9 to E-7						
1	Compressor		4A3808-01	1	1	1	1	1	1						
2	Start Relay		4A3113-01	1	1	1	1	1	1						
3	Start Capacitor	240MFD, 125/165VAC	4A2134-03	1	1	1	1	1	1						
4	Condenser		2A6415-01	1	1	1	1	1	1						
5	Condenser Fan Guard		2A5187-01	1	1	1	1	1	1						
6	Condenser Fan Motor		4A4869-01	1	1	-									
			4A5498-01			1	1	1	1						
7	Condenser Fan Blade		3A5817-01	1	1	1	1	1	1						
7a	Washer		3A6852-01		1	1	1	-							
8	Condensate Tubing		3A6465G01	1	1	1	1	1	1						
9	Evaporator		2A6463-01	1	1	1	1	1	1						
10	Defrost Thermistor		4A4865-01	1	1	1	1	1	1						
11	Defrost Heater		2A5378-01	1	1	1	1	1	-						
			2A7575-01						1						
12	Defrost Thermostat		4A0954-02	1	1	1	1	1	1						
13	Evaporator Fan Motor		4A5343-01	2	2	2	2	2	2						
14	Drier		4A1113-01	1	1	1	1	1	1						
15	High-Pressure Switch		4A2516-02	1	1	1	1	1	1						
16	Thermostatic Expansion Valve		4A5344-01	1	1	1	1	1	1						
17	Thermostatic Expansion Valve Cover		4A4646-01	1	1	1	1	1	1						
18	Thermostatic Expansion Valve Bulb Holder		3A0107-01	1	1	1	1	1	1						
19	Clamp		443461-01	1	1	1	1	1	1						
20	Condensate Water Pump (includes Float Switch)		SP-5080	1	1	1	-								
			4A5546-01				1	1	1						
21	PVC Tubing	L=350 mm	771611438	1	1	1	1	1	1						
22	Cabinet Thermistor		4A4864-01	1	1	1	1	1	1						
23	Condensate Pan		2A7315-01	1	1	1	1	1	1						
24	Condensate Pan Strap		3A8245-01	1	1	1	1	1	1						



## B. Refrigeration Circuit

CR2B-FG/FGY/FS/HS, CR3B-FG/FGY/FS/HS

A-5 to E-7

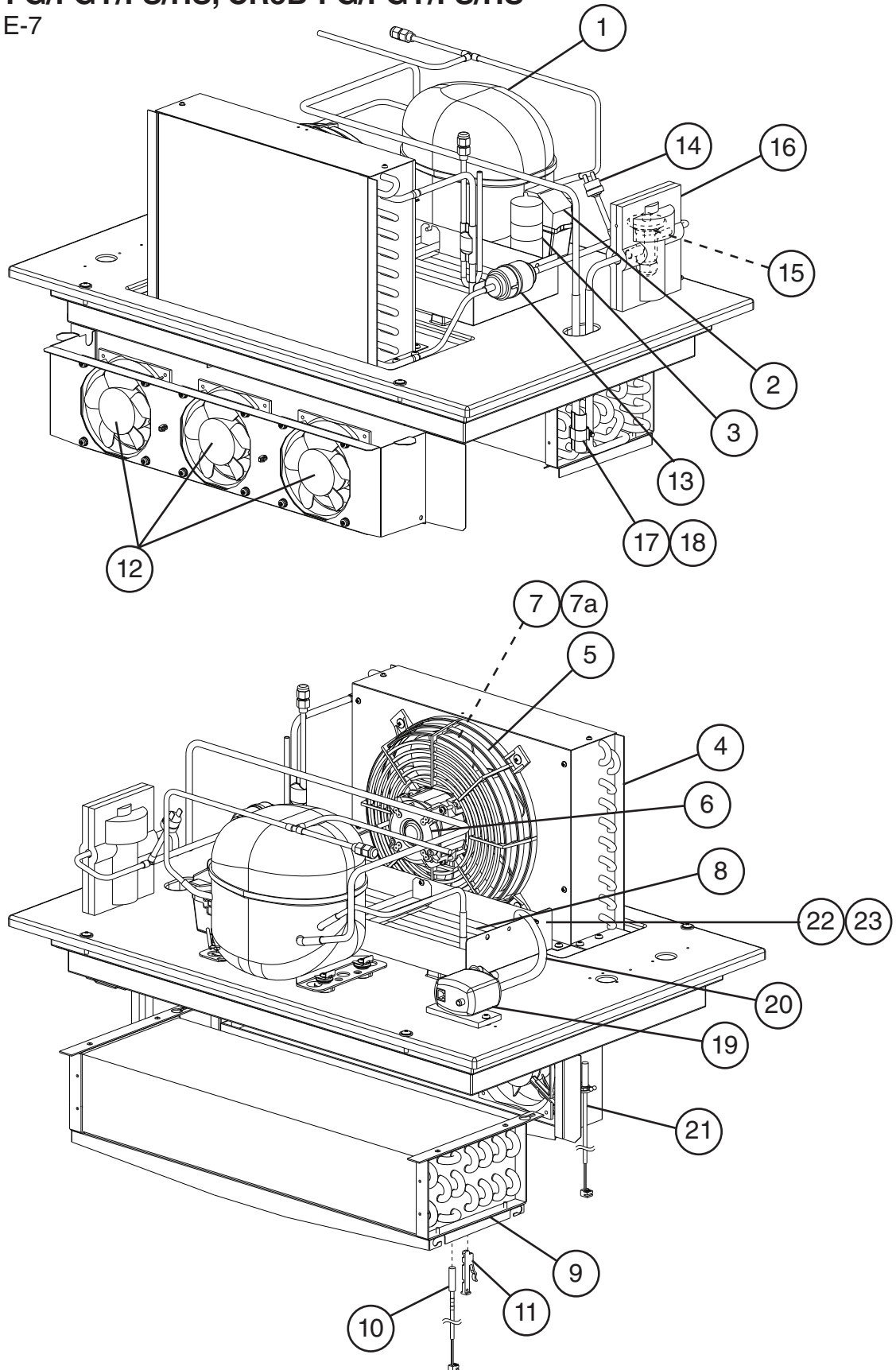

**Title: B. Refrigeration Circuit Model: CR2B-FG/FGY/FS/HS, CR3B-FG/FGY/FS/HS**

Index No.	Description	Material or Model Number	Part Number	Required Number									
				A-5 (A-G)	A-5 (H) to B-5 (A)	B-5 (B) to B-5 (G)	B-5 (H) to D-7	D-8 to E-7					
1	Compressor		4A3958-01	1	1	1	1	1					
2	Start Relay		4A2135-04	1	1	1	1	1					
3	Start Capacitor		4A2134-01	1	1	1	1	1					
4	Condenser		2A5862-01	1	1	1	1	1					
5	Condenser Fan Guard		2A5187-01	1	1	1	1	1					
6	Condenser Fan Motor		4A4869-01	1	1	-							
			4A5498-01			1	1	1					
7	Condenser Fan Blade		3A5817-01	1	1	1	1	1					
7a	Washer		3A6852-01		1	1	1	-					
8	Condensate Tubing		3A6511G01	1	1	1	1	1					
9	Evaporator		2A6464-01	1	1	1	1	1					
10	Defrost Thermistor		4A4865-02	1	1	1	1	1					
11	Thermistor Clip		4A3248G01	1	1	1	1	1					
12	Evaporator Fan Motor		4A5343-01	3	3	3	3	3					
13	Drier		4A1113-01	1	1	1	1	1					
14	High-Pressure Switch		4A2516-01	1	1	1	1	1					
15	Thermostatic Expansion Valve		4A4598-01	1	1	1	1	1					
16	Thermostatic Expansion Valve Cover		4A4646-01	1	1	1	1	1					
17	Thermostatic Expansion Valve Bulb Holder		3A0107-01	1	1	1	1	1					
18	Clamp		443461-01	1	1	1	1	1					
19	Condensate Water Pump (includes float switch)		SP-5080	1	1	1	-						
			4A5546-01				1	1					
20	PVC Tubing	L=350 mm	771611438	1	1	1	1	1					
21	Cabinet Thermistor		4A4864-01	1	1	1	1	1					
22	Condensate Pan		2A7315-02	1	1	1	1	1					
23	Condensate Pan Strap		3A8245-01	1	1	1	1	1					

**B. Refrigeration Circuit**  
**CF2B-FG/FGY/FS/HS, CF3B-FS/HS**  
 A-5 to E-7

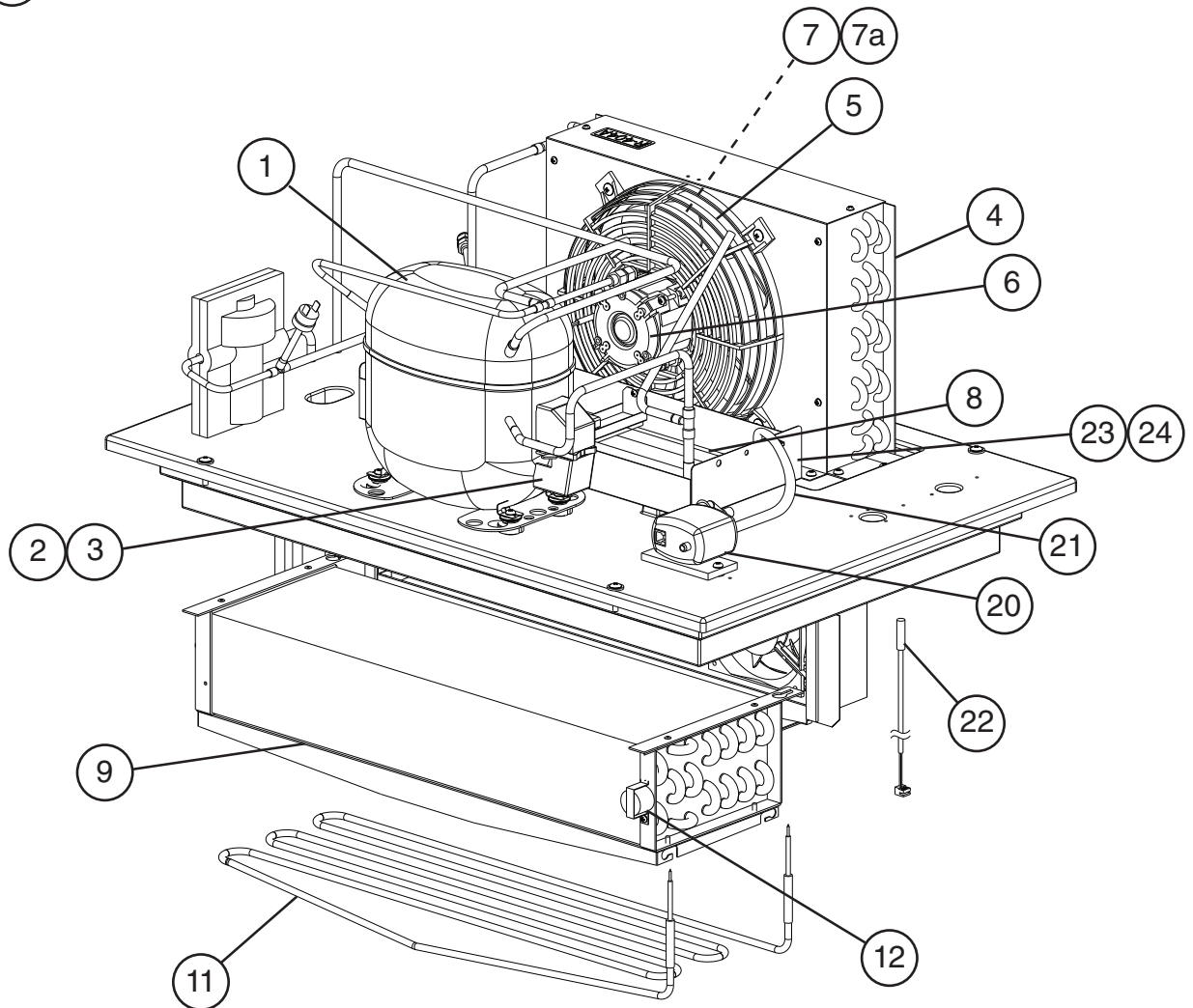
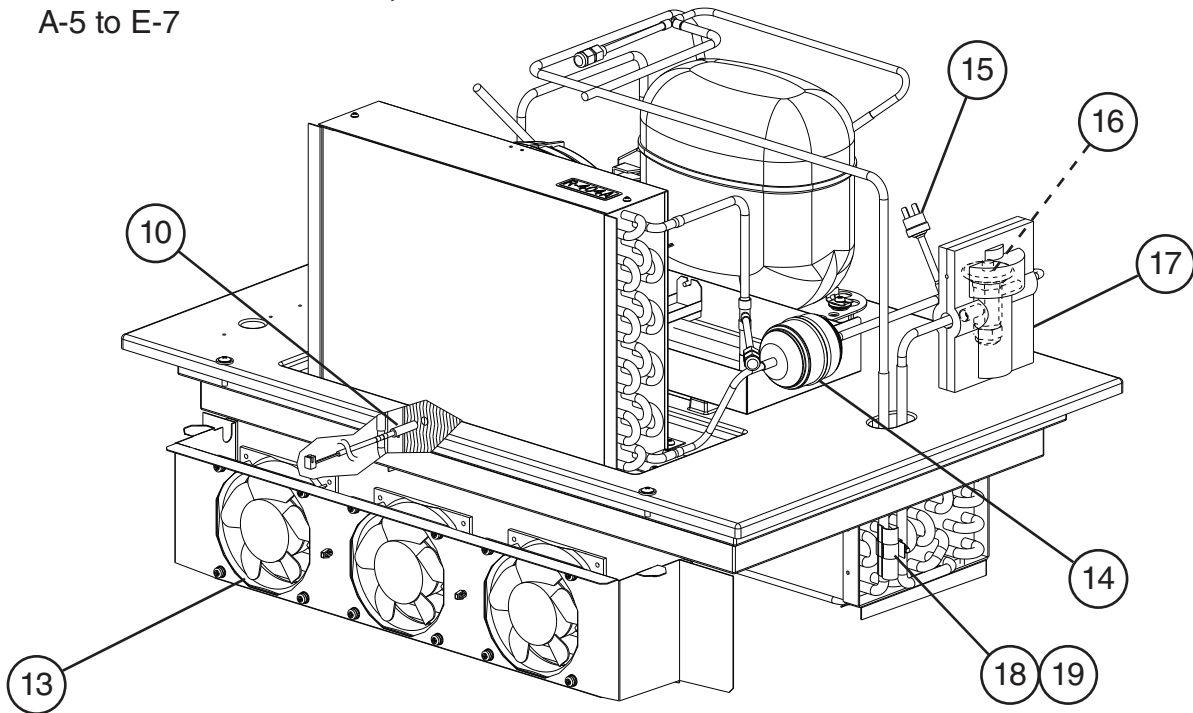

**Title: B. Refrigeration Circuit    Model: CF2B-FG/FGY/FS/HS, CF3B-FS/HS**

Index No.	Description	Material or Model Number	Part Number	Required Number											
				A-5 (A-G)	A-5 (H) to B-5 (A)	B-5 (B) to B-5 (G)	B-5 (H) to D-7	D-8	D-9 to E-7						
1	Compressor		4A3815-01	1	1	1	1	1	1						
2	Protector		4A3679-01	1	1	1	1	1	1						
3	Protector Holder		4A3680-01	1	1	1	1	1	1						
4	Condenser		2A5902-01	1	1	1	1	1	1						
5	Condenser Fan Guard		2A5187-01	1	1	1	1	1	1						
6	Condenser Fan Motor		4A4869-01	1	1	-									
			4A5498-01			1	1	1	1						
7	Condenser Fan Blade		3A5817-01	1	1	1	1	1	1						
7a	Washer		3A6852-01		1	1	1	-							
8	Condensate Tubing		3A6464G01	1	1	1	1	1	1						
9	Evaporator		2A6464-01	1	1	1	1	1	1						
10	Defrost Thermistor		4A4865-01	1	1	1	1	1	1						
11	Defrost Heater		2A5991-01	1	1	1	1	1	-						
			2A7585-01							1					
12	Defrost Thermostat		4A0954-02	1	1	1	1	1	1						
13	Evaporator Fan Motor		4A5343-01	3	3	3	3	3	3						
14	Drier		4A0924-01	1	1	1	1	1	1						
15	High-Pressure Switch		4A2516-02	1	1	1	1	1	1						
16	Thermostatic Expansion Valve		4A5161-01	1	1	1	1	1	1						
17	Thermostatic Expansion Valve Cover		4A4646-01	1	1	1	1	1	1						
18	Thermostatic Expansion Valve Bulb Holder		3A0107-01	1	1	1	1	1	1						
19	Clamp		443461-01	1	1	1	1	1	1						
20	Condensate Water Pump (includes float switch)		SP-5080	1	1	1	-								
			4A5546-01				1	1	1						
21	PVC Tubing	L=350 mm	771611438	1	1	1	1	1	1						
22	Cabinet Thermistor		4A4864-01	1	1	1	1	1	1						
23	Condensate Pan		2A7315-02	1	1	1	1	1	1						
24	Condensate Pan Strap		3A8245-01	1	1	1	1	1	1						

### C. Control Box Assembly

**CR1B-FG/FGY/FS/HS, CF1B-FG/FS/HS, CR2B-FG/FGY/FS/HS, CR3B-FG/FGY/FS/HS, CF3B-FS/HS(One Section)**

A-5 to E-7

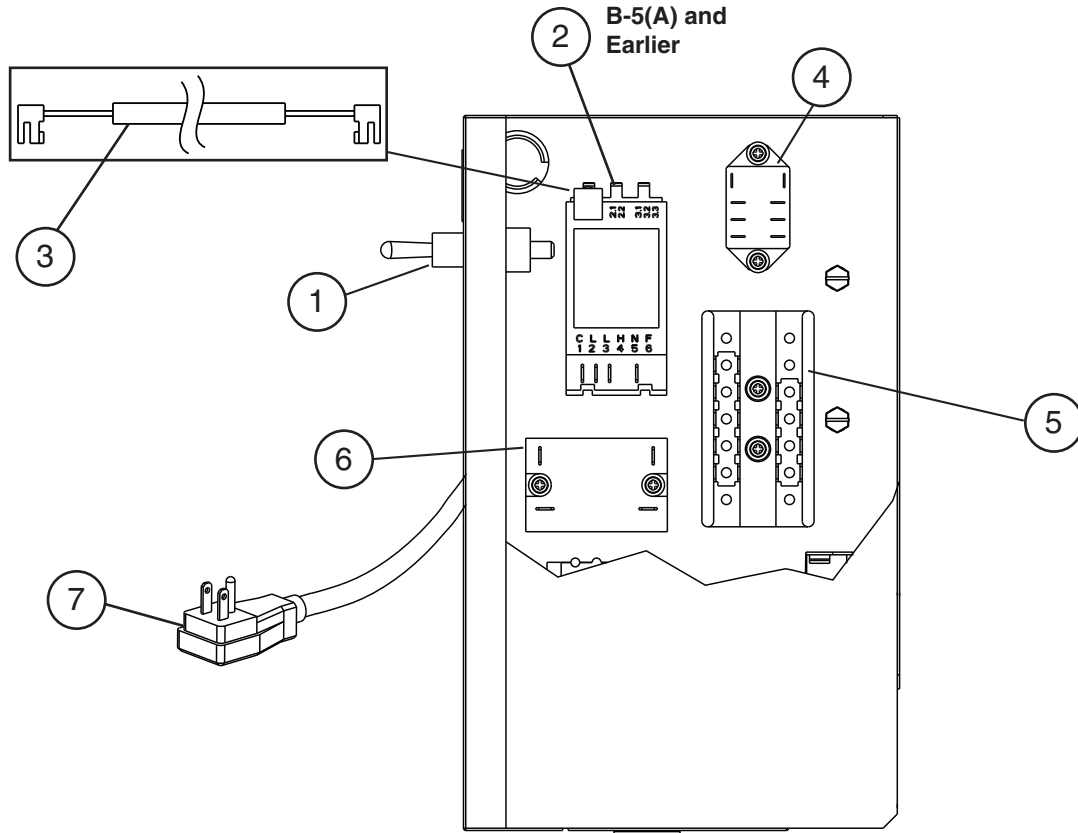

Title: C. Control Box Assembly Model: CR1B-FG/FGY/FS/HS, CF1B-FG/FS/HS, CR2B-FG/FGY/FS/HS, CR3B-FG/FGY/FS/HS, CF3B-FS/HS(One Section)											
Index No.	Description	Material or Model Number	Part Number	Required Number							
				A-5 to B-5 (A)	B-5 (B) to B-6 (E)	B-6 (F) to E-7					
1	Power Switch		4A0424-01	1	1	1					
2	Control Module	<b>CR_B-XX</b> <b>CF_B-XX</b>	4A4861-03 4A5101-03	1	See Page 5 for Exact Beginning Serial Numbers for Control Module Change. Later Aux Codes: See "A. Main Assembly" for Control Module						
3	Display Cable		4A4863-01	1	-						
4	Door Switch Relay	120VAC	406132-07	1	1	1					
5	Terminal Block		4A2619-01	1	1	1					
6	Compressor Relay	120VAC	4A1307-01 4A3140-01	1	1	-					
7	Power Cord		4A0520-01	1	1	1					

### C. Control Box Assembly CF2B-FG/FGY/FS/HS, CF3B-FS/HS(Two Section) A-5 to E-7

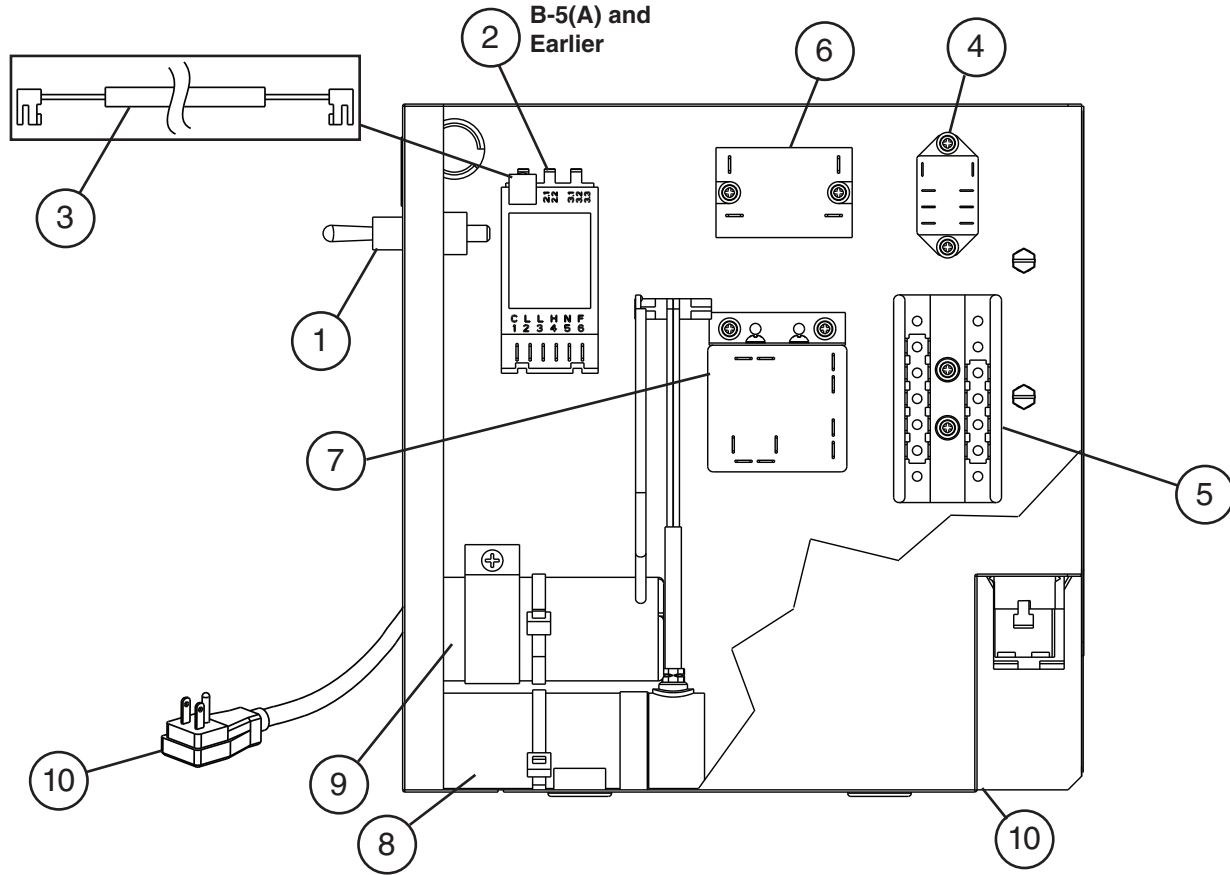

Title: C. Control Box Assembly		Model: CF2B-FG/FGY/FS/HS, CF3B-FS/HS(Two Section)		Required Number								
Index No.	Description	Material or Model Number	Part Number	A-5 to B-5 (A)	B-5 (B) to B-6 (E)	B-6 (F) to E-7						
1	Power Switch		4A0424-01	1	1	1						
2	Control Module		4A5101-03	1	See Page 5 for Exact Beginning Serial Numbers for Control Module Change. Later Aux Codes: See "A. Main Assembly" for Control Module							
3	Display Cable		4A4863-01	1	-							
4	Door Switch Relay	120VAC	406132-07	1	1	1						
5	Terminal Block		4A2619-01	1	1	1						
6	Compressor Relay	120VAC	4A1307-01	1	1	-						
			4A3140-01			1						
7	Start Relay		4A3683-01	1	1	1						
8	Run Capacitor	23.5MFD, 280VAC	4A4208-01	1	1	1						
9	Start Capacitor	410MFD, 125/165VAC	4A2134-02	1	1	1						
10	Power Cord		4A0520-01	1	1	1						

## D. Door-Right Hinged

Full Glass: CR1B-FG, CF1B-FG, CR2B-FG, CF2B-FG, CR3B-FG

A-5 to E-7

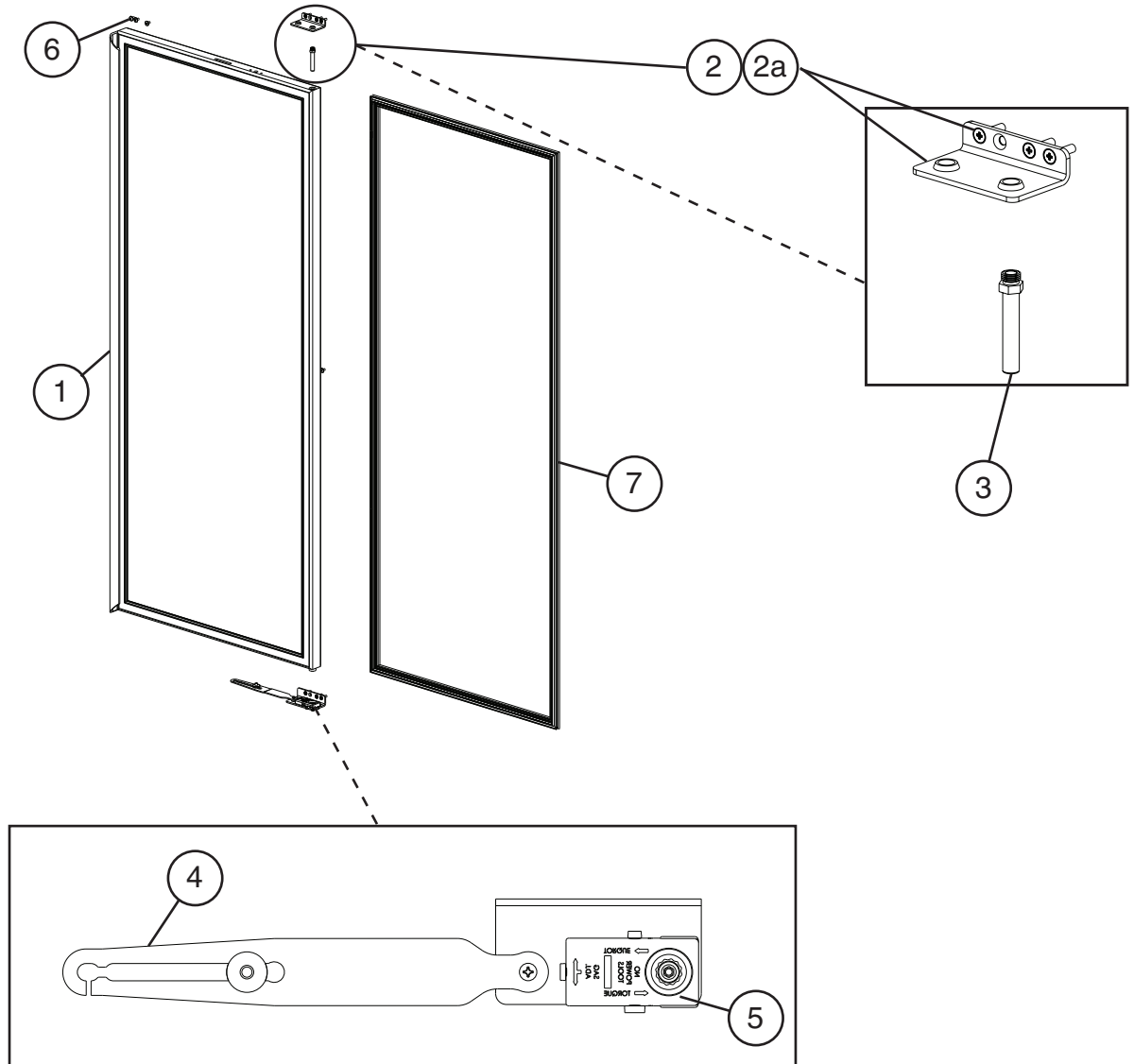

Title: D. Door-Right Hinged Model: Full Glass: CR1B-FG, CF1B-FG, CR2B-FG, CF2B-FG, CR3B-FG										
Index No.	Description	Material or Model Number	Part Number	Required Number						
				A-5 to E-7						
1	Right Glass Door	CR_B-FG	1A2296-01	1						
		CF_B-FG	1A2367-01	1						
2	Upper Hinge Bracket		3A6844-01	1						
2a	Countersunk Screw	5x20, SS	7C42-0520	3						
3	Hinge Pin		3A6867-01	1						
4	Arm		4A5991-01	1						
5	Torque Master		4A5984-01	1						
6	Truss Head Screw (filler screws)	5x10, SS	7C32-0510	8						
7	Door Gasket		3A6843-01	1						

## D. Door-Right Hinged

Full Glass: CR1B-FGY, CF1B-FGY, CR2B-FGY, CF2B-FGY, CR3B-FGY

D-5 to E-7

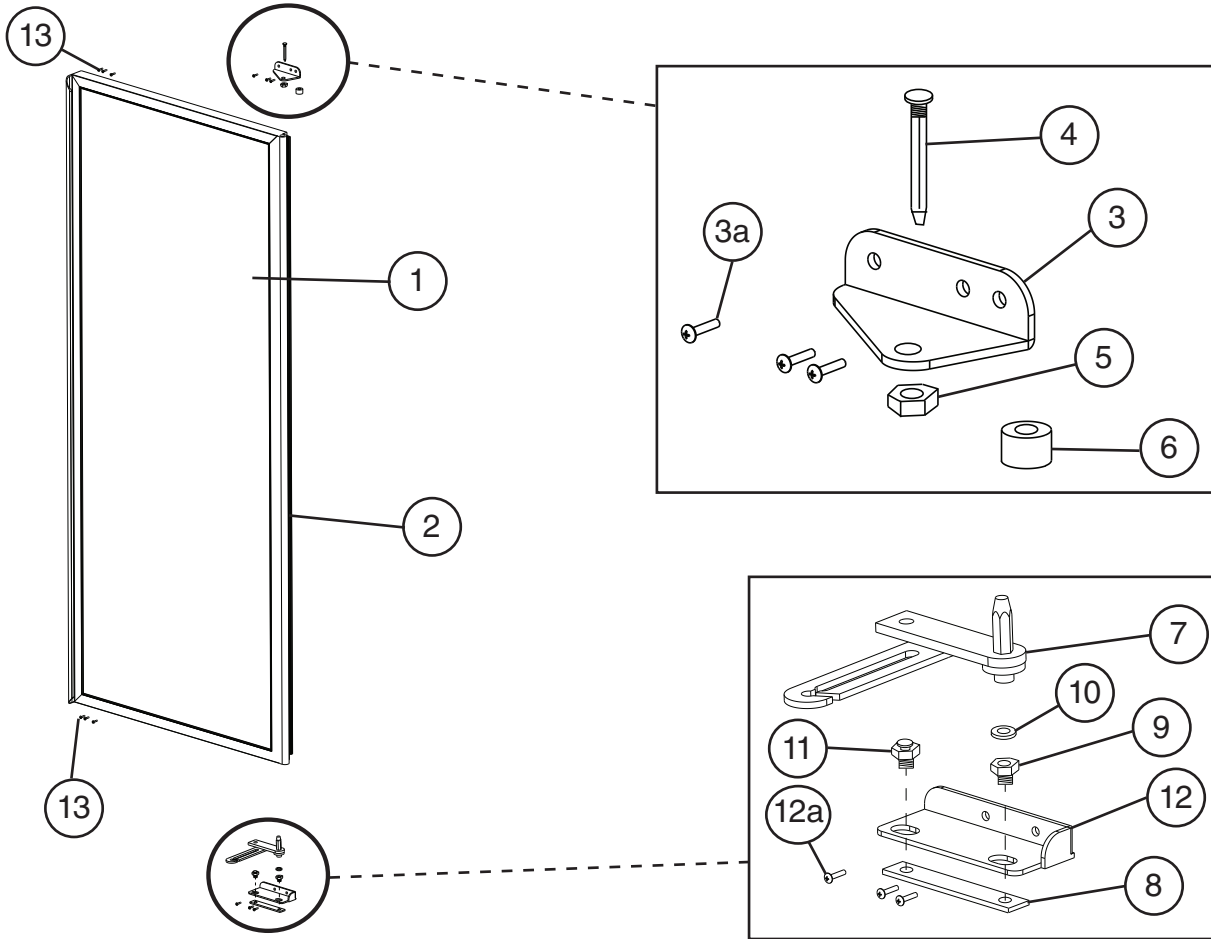

Title: D. Door-Right Hinged Model: Full Glass: CR1B-FGY, CF1B-FGY, CR2B-FGY, CF2B-FGY, CR3B-FGY					Required Number												
Index No.	Description	Material or Model Number	Part Number	D-5 to E-7													
				1	Right Glass Door (includes items 2 through 10)	CR_B-FGY	2A7116-02	1									
	CF_B-FGY	2A7116-04	1														
2	Door Gasket		3A7945-01	1													
3	Upper Hinge Bracket		3A7946-03	1													
3a	Truss Head Screw (filler screws)	5x25, SS	7C32-0525	3													
4	Hinge Pin (tension rod)		3A7946-04	1													
5	Lock Nut		3A7946-05	1													
6	Upper Bushing		3A7946-12	1													
7	Lower Hinge		3A7946-01	1													
8	Backer Plate		3A7946-08	1													
9	Lower Hinge Bushing		3A7946-09	1													
10	Nylon Washer		3A7946-10	1													
11	Slide Pin		3A7946-11	1													
12	Lower Hinge Bracket		3A7946-07	1													
12a	Truss Head Screw	5x25, SS	7C32-0525	3													
13	Truss Head Screw (filler screws)	5x10, SS	7C32-0510	6													



## D. Door-Right Hinged

Full Solid: CR1B-FS, CF1B-FS, CR2B-FS, CF2B-FS, CR3B-FS, CF3B-FS

A-5 to E-7

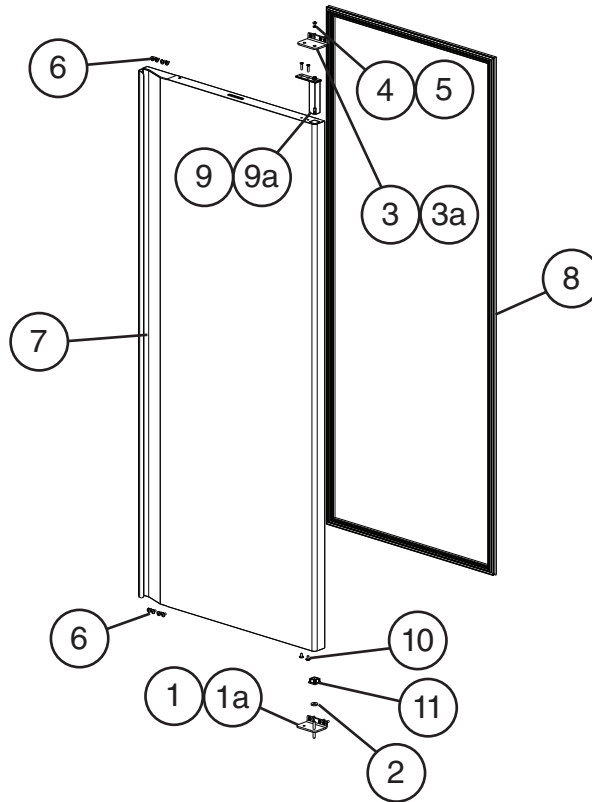

Title: D. Door-Right Hinged Model: Full Solid: CR1B-FS, CF1B-FS, CR2B-FS, CF2B-FS, CR3B-FS, CF3B-FS					Required Number							
Index No.	Description	Material or Model Number	Part Number	A-5 to B-5 (D)	B-5 (E) to E-7							
1	Lower Hinge Bracket		3A6250G01	1	1							
1a	Countersunk Screw	5x20, SS	7C42-0520	3	3							
2	Thrust Washer		4A5234-01	1	1							
3	Upper Hinge Bracket		3A6249-01	1	1							
3a	Countersunk Screw	5x20, SS	7C42-0520	3	3							
4	Lock Washer		4A5231-01	1	1							
5	Screw		4A5230-01	1	1							
6	Truss Head Screw (filler screws)	5x10, SS	7C32-0510	8	8							
7	Right Door Assembly (includes items 8 through 11)	<b>CR_B-FS</b>	2A6258G01	1	-							
			2A6806G01		1							
		<b>CF_B-FS</b>	2A6258G01	1	1							
8	Door Gasket		2A5192-14	1	1							
9	Hinge Cartridge		3A6258-01	1	1							
9a	Countersunk Screw	5x20, SS	7C42-0520	2	2							
10	Truss Head Screw (filler screws)	5x10, SS	7C32-0510	2	2							
11	Bearing		4A5232-01	1	1							

### D. Door-Right Hinged

Half Solid: CR1B-HS, CF1B-HS, CR2B-HS, CF2B-HS, CR3B-HS, CF3B-HS

A-5 to E-7

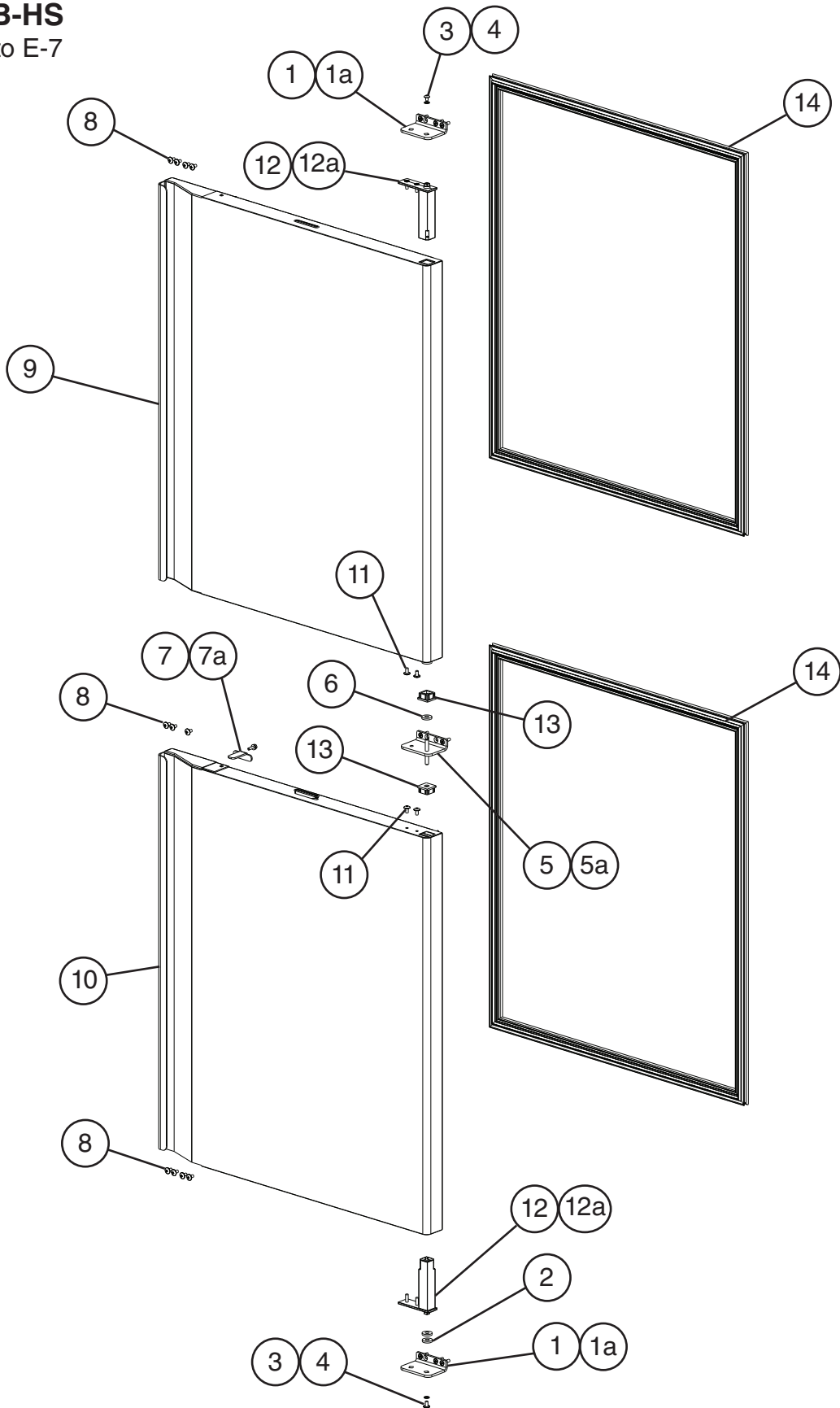

Title: D. Door-Right Hinged Model: Half Solid: CR1B-HS, CF1B-HS, CR2B-HS, CF2B-HS, CR3B-HS, CF3B-HS											
Index No.	Description	Material or Model Number	Part Number	Required Number							
				A-5 to B-6 (E)	B-6 (F) to E-7						
1	Upper/Lower Hinge Bracket		3A6249-01	2	2						
1a	Countersunk Screw	5x20, SS	7C42-0520	6	6						
2	Thrust Washer		4A5233-01	2	2						
3	Lock Washer		4A5231-01	2	2						
4	Screw		4A5230-01	2	2						
5	Middle Hinge Bracket		3A6250G01	1	1						
5a	Countersunk Screw	5x20, SS	7C42-0520	2	2						
6	Thrust Washer		4A5234-01	1	1						
7	Half-Door Lock		4A5249-01	1	1						
7a	Bolt		449879-08	1	1						
8	Truss Head Screw (filler screws)	5x10, SS	7C32-0510	11	11						
9	Upper Right/Lower Left Door Assembly (includes half the quantity of items 11 through 14)		2A6252G01	1	-						
			2A6804G01		1						
10	Lower Right/Upper Left Door Assembly (includes half the quantity of items 11 through 14)		2A6253G01	1	-						
			2A6805G01		1						
11	Truss Head Screw (filler screws)	5x10, SS	7C32-0510	4	4						
12	Hinge Cartridge		3A6258-01	2	2						
12a	Countersunk Screw	5x20, SS	7C42-0520	4	4						
13	Bearing		4A5232-01	2	2						
14	Door Gasket		2A5192-02	2	2						

**E. Door-Left Hinged**  
**Full Glass: CR2B-FG, CF2B-FG, CR3B-FG**  
 A-5 to E-7

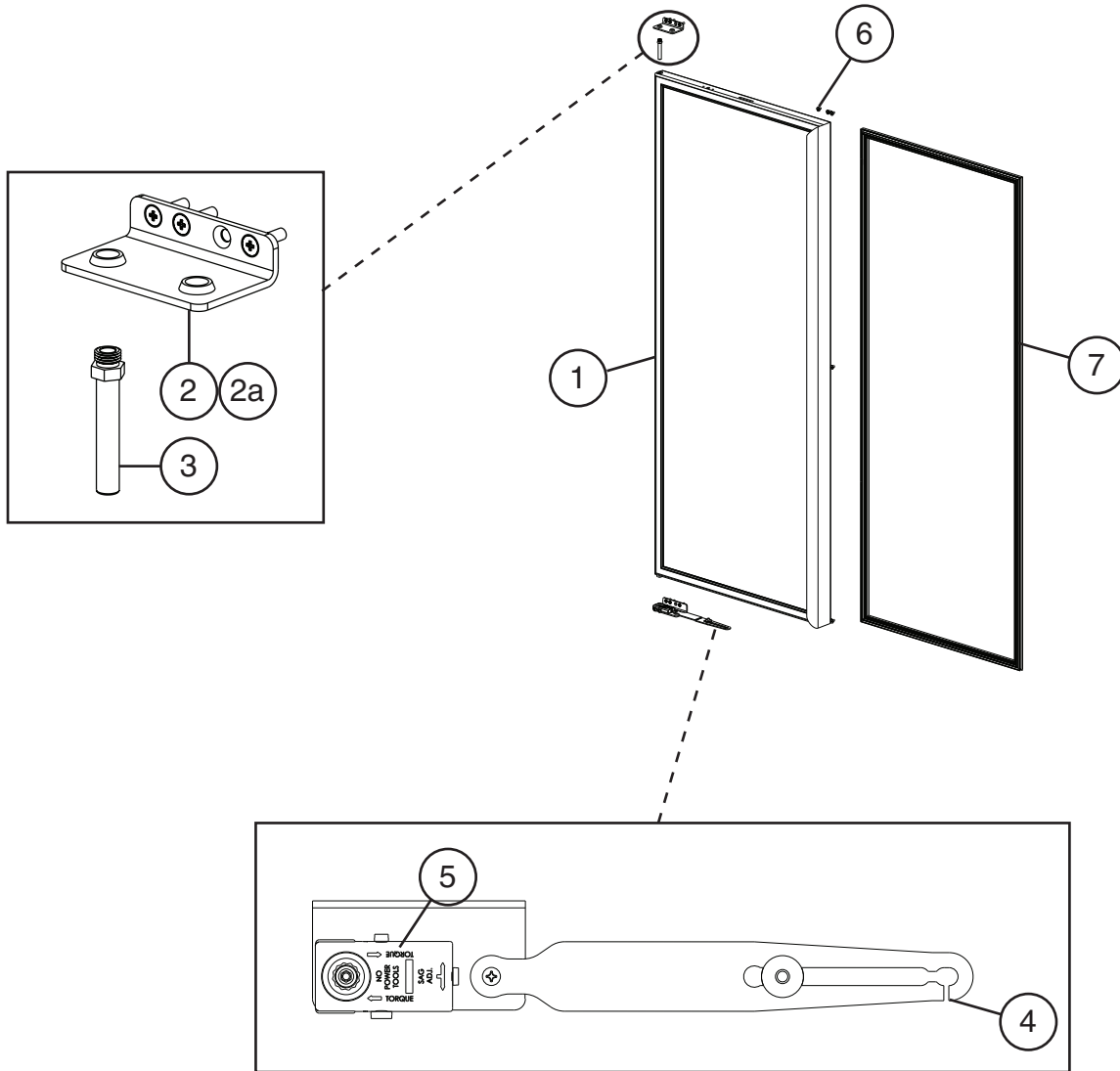

Title: E. Door-Left Hinged Model: Full Glass: CR2B-FG, CF2B-FG, CR3B-FG					Required Number												
Index No.	Description	Material or Model Number	Part Number	A-5 to E-7													
1	Left Glass Door	CR2B-FG	1A2296-02	1													
		CF2B-FG	1A2367-02	1													
2	Upper Hinge Bracket		3A6844-01	1													
2a	Countersunk Screw	5x20, SS	7C42-0520	3													
3	Hinge Pin		3A6867-01	1													
4	Arm		4A5991-01	1													
5	Torque Master		4A5984-01	1													
6	Truss Head Screw (filler screws)	5x10, SS	7C32-0510	8													
7	Door Gasket		3A6843-01	1													

## E. Door-Left Hinged

### Full Glass: CR2B-FGY, CF2B-FGY, CR3B-FGY

D-5 to E-7

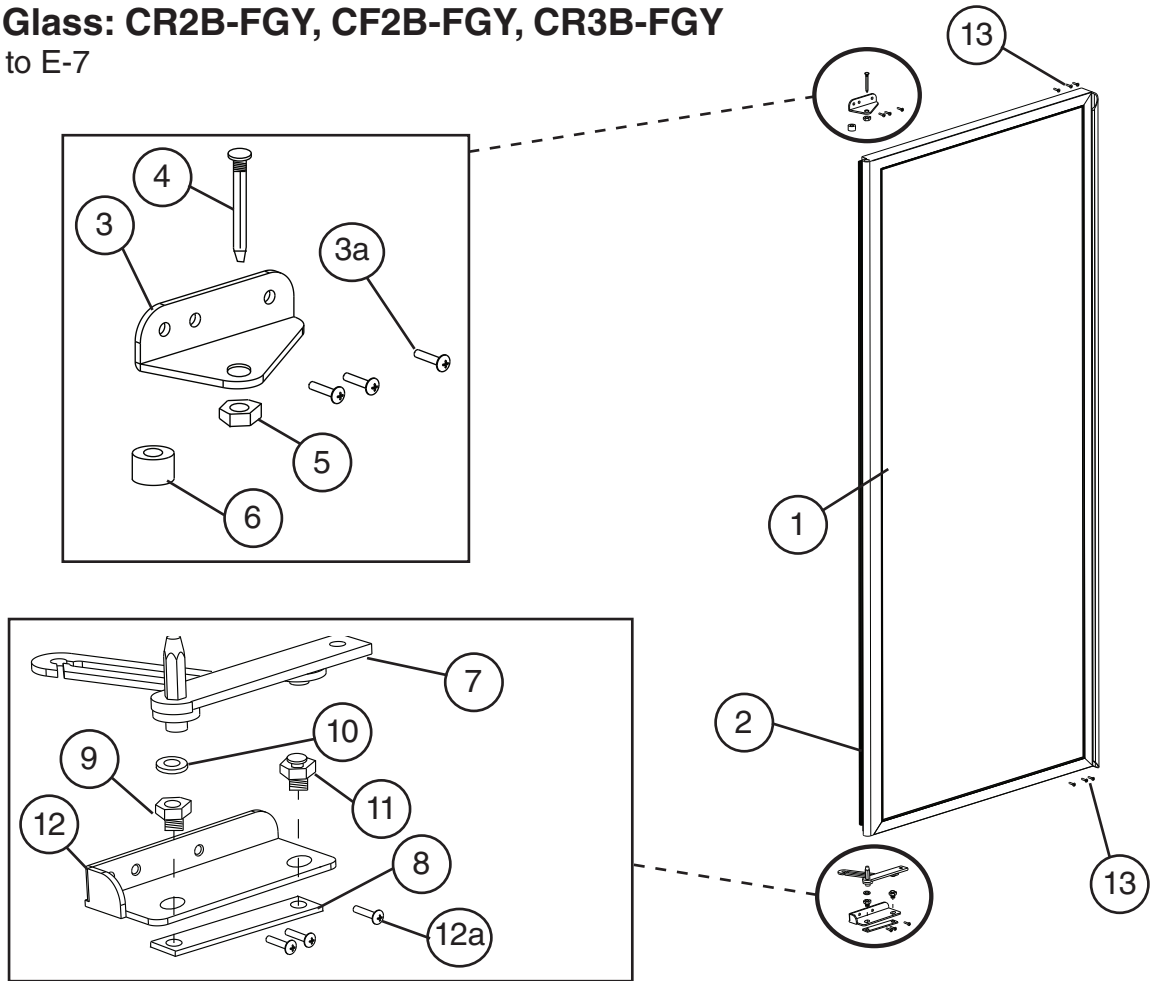

Title: E. Door-Left Hinged Model: Full Glass: CR2B-FGY, CF2B-FGY, CR3B-FGY					Required Number												
Index No.	Description	Material or Model Number	Part Number	D-5 to E-7													
				1	Left Glass Door (includes items 2 through 10)	CR_B-FGY	2A7116-01	1									
	CF2B-FGY	2A7116-03	1														
2	Door Gasket		3A7945-01	1													
3	Upper Hinge Bracket		3A7946-02	1													
3a	Truss Head Screw	5x25, SS	7C32-0525	3													
4	Hinge Pin (tension rod)		3A7946-04	1													
5	Lock Nut		3A7946-05	1													
6	Upper Bushing		3A7946-12	1													
7	Lower Hinge		3A7946-01	1													
8	Backer Plate		3A7946-08	1													
9	Lower Hinge Bushing		3A7946-09	1													
10	Nylon Washer		3A7946-10	1													
11	Slide Pin		3A7946-11	1													
12	Lower Hinge Bracket		3A7946-06	1													
12a	Truss Head Screw	5x25, SS	7C32-0525	3													
13	Truss Head Screw (filler screws)	5x10, SS	7C32-0510	6													

## E. Door-Left Hinged

Full Solid: CR2B-FS, CF2B-FS, CR3B-FS, CF3B-FS

V-5 to E-7

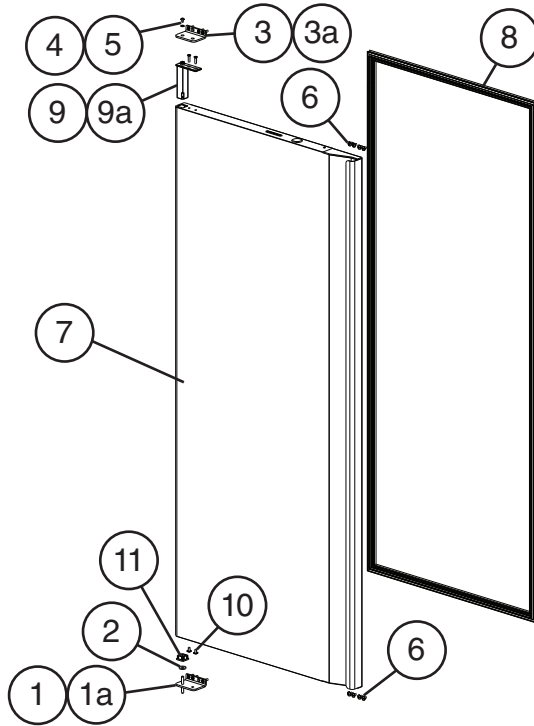

Title: E. Door-Left Hinged Model: Full Solid: CR2B-FS, CF2B-FS, CR3B-FS, CF3B-FS										
Index No.	Description	Material or Model Number	Part Number	Required Number						
				V-5 to B-5 (D)	B-5 (E) to E-7					
1	Lower Hinge Bracket		3A6250G02	1	1					
1a	Countersunk Screw	5x20, SS	7C42-0520	3	3					
2	Thrust Washer		4A5234-01	1	1					
3	Upper Hinge Bracket		3A6249-01	1	1					
3a	Countersunk Screw	5x20, SS	7C42-0520	3	3					
4	Lock Washer		4A5231-01	1	1					
5	Screw		4A5230-01	1	1					
6	Truss Head Screw (filler screws)	5x10, SS	7C32-0510	8	8					
7	Left Door Assembly (includes items 8 through 11)	CR_B-FS	2A6264G01	1	-					
			2A6808G01		1					
		CF_B-FS	2A6264G01	1	1					
8	Door Gasket		2A5192-01	1	1					
9	Hinge Cartridge		3A6258-01	1	1					
9a	Countersunk Screw	5x20, SS	7C42-0520	2	2					
10	Truss Head Screw (filler screws)	5x10, SS	7C32-0510	2	2					
11	Bearing		4A5232-01	1	1					

## E. Door-Left Hinged

Half Solid: CR2B-HS, CF2B-HS, CR3B-HS, CF3B-HS

A-5 to E-7

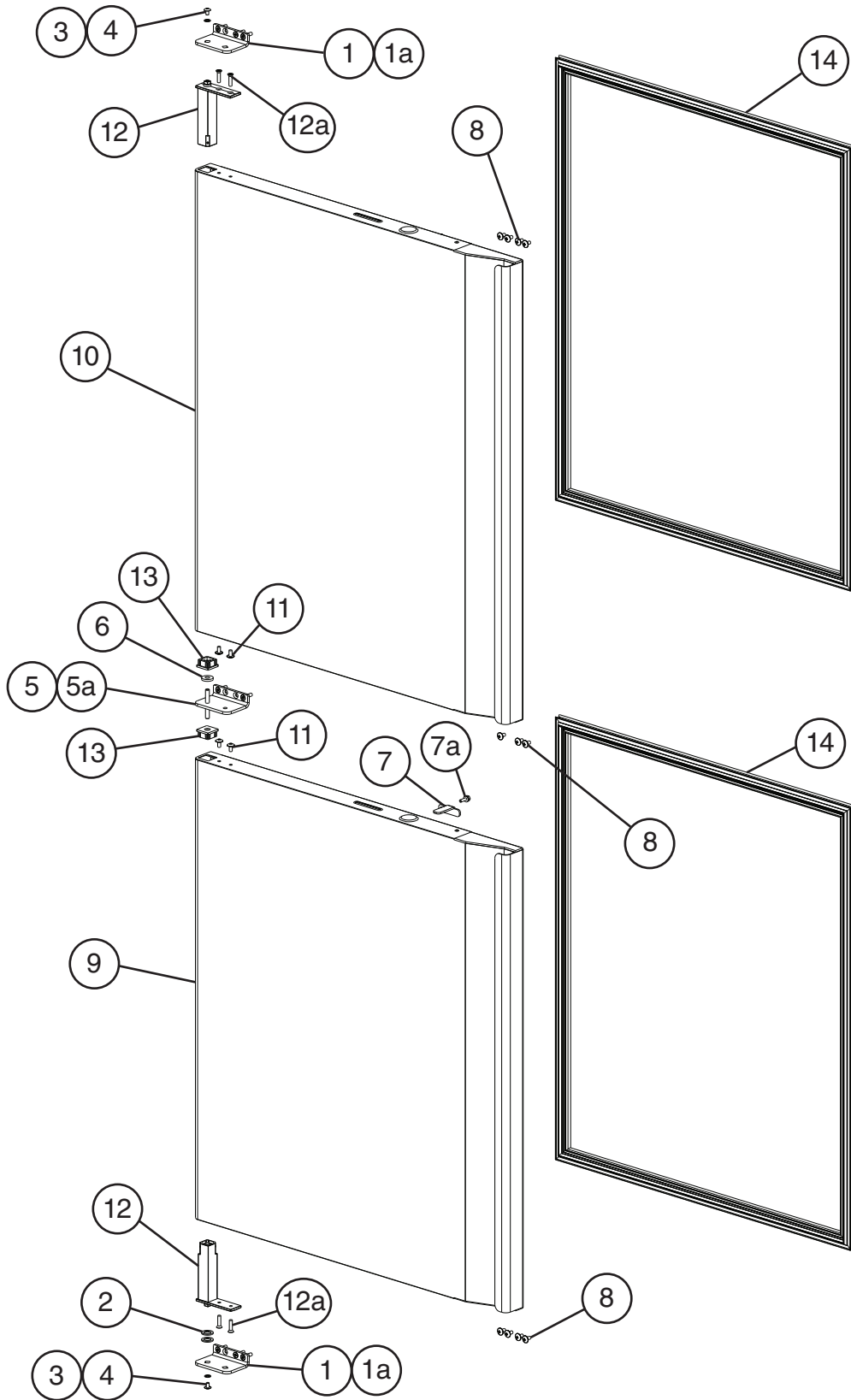

Title: E. Door-Left Hinged Model: Half Solid: CR2B-HS, CF2B-HS, CR3B-HS, CF3B-HS											
Index No.	Description	Material or Model Number	Part Number	Required Number							
				A-5 to B-6 (E)	B-6 (F) to E-7						
1	Upper/Lower Hinge Bracket		3A6249-01	2	2						
1a	Countersunk Screw	5x20, SS	7C42-0520	6	6						
2	Thrust Washer		4A5233-01	2	2						
3	Lock Washer		4A5231-01	2	2						
4	Screw		4A5230-01	2	2						
5	Middle Hinge Bracket		3A6250G02	1	1						
5a	Countersunk Screw	5x20, SS	7C42-0520	2	2						
6	Thrust Washer		4A5234-01	1	1						
7	Half-Door Lock		4A5249-01	1	1						
7a	Bolt	5x16, SS	449879-08	1	1						
8	Truss Head Screw (filler screws)	5x10, SS	7C32-0510	11	11						
9	Upper Right/Lower Left Door Assembly (includes half the quantity of items 11 through 14)		2A6252G01	1	-						
			2A6804G01		1						
10	Lower Right/Upper Left Door Assembly (includes half the quantity of items 11 through 14)		2A6253G01	1	-						
			2A6805G01		1						
11	Truss Head Screw (filler screws)	5x10, SS	7C32-0510	4	4						
12	Hinge Cartridge		3A6258-01	2	2						
12a	Countersunk Screw	5x20, SS	7C42-0520	4	4						
13	Bearing		4A5232-01	2	2						
14	Door Gasket		2A5192-02	2	2						



## F. Accessories & Labels

**CR1B-FG/FGY/FS/HS, CF1B-FG/FGY/FS/HS, CR2B-FG/FGY/FS/HS,  
CF2B-FG/FGY/FS/HS, CR3B-FG/FGY/FS/HS, CF3B-FS/HS**

A-5 to E-7

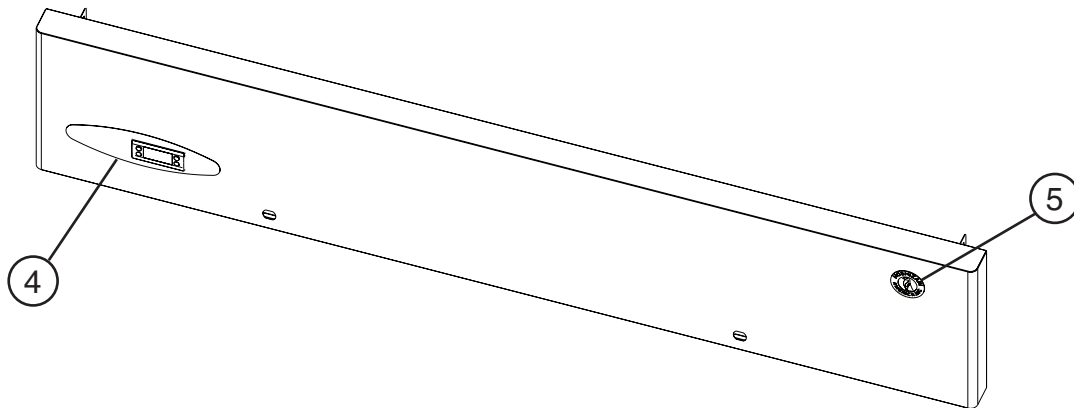
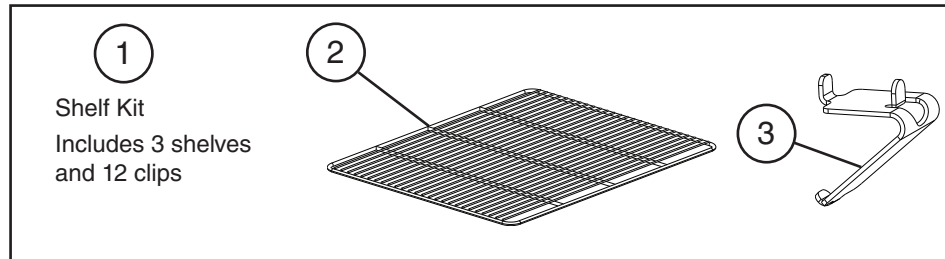

**Plated Caster**

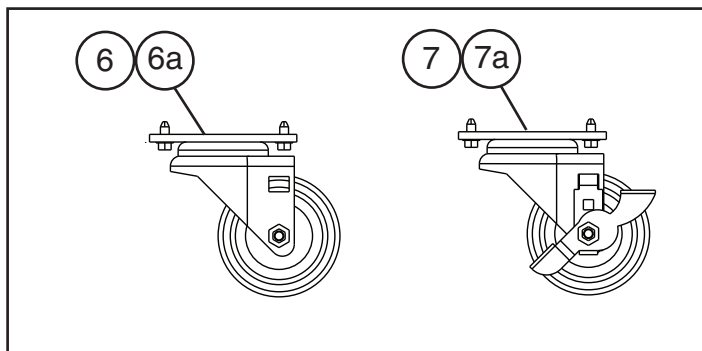

**Plated Caster Shim**

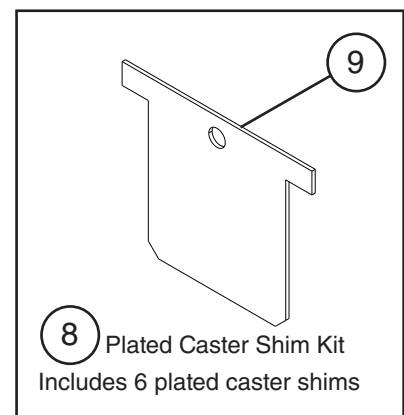

**Stem Caster**

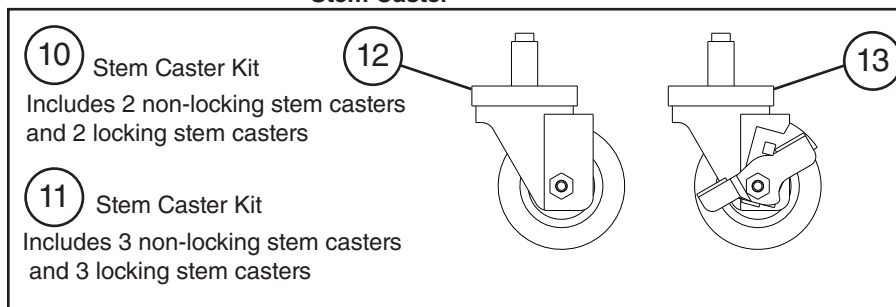

**Stem Caster Shim**

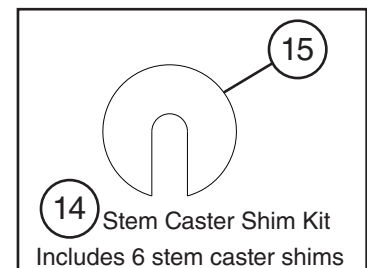

<b>Title: F. Accessories &amp; Labels    Model: CR1B-FG/FGY/FS/HS, CF1B-FG/FGY/FS/HS, CR2B-FG/FGY/FS/HS, CF2B-FG/FGY/FS/HS, CR3B-FG/FGY/FS/HS, CF3B-FS/HS</b>										
Index No.	Description	Material or Model Number	Part Number	Required Number						
				A-5 to E-7 (F)	E-7 (G)					
1	Shelf Kit (3 Pack) (includes items 2 and 3) (HS-5053)	CR1B-FG/FGY/FS/HS CF1B-FG/FGY/FS/HS CR3B-FS/HS CF3B-FS/HS	3A6902A01	1	1					
	Shelf Kit (3 Pack) (one kit includes half of items 2 and 3) (HS-5048)	CR2B-FG/FGY/FS/HS CF2B-FG/FGY/FS/HS CR3B-FS/HS CF3B-FS/HS	3A6874A01	2	2					
2	Shelf	CR1B-FG/FGY/FS/HS CF1B-FG/FGY/FS/HS CR3B-FS/HS CF3B-FS/HS	3A6876-03	3	3					
		CR2B-FG/FGY/FS/HS CR3B-FS/HS CF2B-FG/FGY/FS/HS CF3B-FS/HS	3A6876-01	6	6					
3	Shelf Clip	CR1B-FG/FGY/FS/HS CF1B-FG/FGY/FS/HS CR3B-FS/HS CF3B-FS/HS	428957-01	12	12					
		CR2B-FG/FGY/FS/HS CF2B-FG/FGY/FS/HS CR3B-FS/HS CF3B-FS/HS		24	24					
4	Commercial Label	CR1B-FG/FGY/FS/HS CR2B-FG/FGY/FS/HS CR3B-FG/FGY/FS/HS	3A7757-01	1	1					
		CF1B-FG/FGY/FS/HS CF2B-FG/FGY/FS/HS CF3B-FG/FGY/FS/HS	3A7757-02	1	1					
5	Penguin Label		456246-02	1	1					

Title: F. Accessories & Labels Model: CR1B-FG/FGY/FS/HS, CF1B-FG/FGY/FS/HS, CR2B-FG/FGY/FS/HS, CF2B-FG/FGY/FS/HS, CR3B-FG/FGY/FS/HS, CF3B-FS/HS										
Index No.	Description	Material or Model Number	Part Number	Required Number						
				A-5 to E-7 (F)	E-7 (G)					
<b>Plate Caster</b>										
6	4-Inch Locking Plated Caster	CR1B-FG/FS CF1B-FG/FGY/FS CR2B-FG/FGY/FS/HS CF2B-FG/FS/HS	4A4275-01	2	2					
		CR1B-FGY/HS CF1B-HS CF2B-FGY		2	-					
		CR3B-FS/HS CF3B-FS/HS		3	3					
		CR3B-FGY		3	-					
6a	Hex Head Tapping Bolt	CR1B-FG/FS CF1B-FG/FGY/FS CR2B-FG/FGY/FS/HS CF2B-FG/FS/HS	4A5213-01	8	8					
		CR1B-FGY/HS CF1B-HS CF2B-FGY		8	-					
		CR3B-FS/HS CF3B-FS/HS		12	12					
		CR3B-FGY		12	-					
7	4-Inch Non-Locking Plated Caster	CR1B-FG/FS CF1B-FG/FGY/FS CR2B-FG/FGY/FS/HS CF2B-FG/FS/HS	4A4275-02	2	2					
		CR1B-FGY/HS CF1B-HS CF2B-FGY		2	-					
		CR3B-FS/HS CF3B-FS/HS		3	3					
		CR3B-FGY		3	-					
7a	Hex Head Tapping Bolt	CR1B-FG/FS CF1B-FG/FGY/FS CR2B-FG/FGY/FS/HS CF2B-FG/FS/HS	4A5213-01	8	8					
		CR1B-FGY/HS CF1B-HS CF2B-FGY		8	-					
		CR3B-FS/HS CF3B-FS/HS		12	12					
		CR3B-FGY		12	-					
8	Plated Caster Shim Kit (includes 6 of item 9)	CR1B-FG/FS CF1B-FG/FGY/FS CR2B-FG/FGY/FS/HS CF2B-FG/FS/HS	HS-3724	1	1					
		CR1B-FGY/HS CF1B-HS CF2B-FGY		1	-					
		CR3B-FS/HS CF3B-FS/HS		1	1					
		CR3B-FGY		1	-					

<b>Title: F. Accessories &amp; Labels    Model: CR1B-FG/FGY/FS/HS, CF1B-FG/FGY/FS/HS, CR2B-FG/FGY/FS/HS, CF2B-FG/FGY/FS/HS, CR3B-FG/FGY/FS/HS, CF3B-FS/HS</b>										
Index No.	Description	Material or Model Number	Part Number	Required Number						
				A-5 to E-7 (F)	E-7 (G)					
9	Plated Caster Shim	CR1B-FG/FS CF1B-FG/FGY/FS CR2B-FG/FGY/FS/HS CF2B-FG/FS/HS	4A5208-01	4	4					
		CR1B-FGY/HS CF1B-HS CF2B-FGY		4	-					
		CR3B-FS/HS CF3B-FS/HS		6	6					
		CR3B-FGY		6	-					
<b>Stem Caster</b>										
10	4-inch Stem Caster Kit (includes 2 each of items 12 and 13)	CR1B-FGY/HS CF1B-HS CF2B-FGY	HS-3546		1					
11	4-inch Stem Caster Kit (includes 3 each of items 12 and 13)	CR3B-FGY	HS-3547		1					
12	4-inch Non-Locking Stem Caster	CR1B-FGY/HS CF1B-HS CF2B-FGY	4A1347-01		2					
		CR3B-FGY			3					
13	4-inch Locking Stem Caster	CR1B-FGY/HS CF1B-HS CF2B-FGY	4A1347-02		2					
		CR3B-FGY			3					
14	Stem Caster Shim Kit (includes 6 of item 15)	CR1B-FGY/HS CF1B-HS CF2B-FGY CR3B-FGY	HS-3590		1					
15	Stem Caster Shim	CR1B-FGY/HS CF1B-HS CF2B-FGY CR3B-FGY	4A3658-01		4					
		CR3B-FGY			6					