

# Hoshizaki America, Inc.

## Cubelet Icemaker / Dispenser

### Models

DCM-230HE-UK

DCM-230HE-CT



“A Superior Degree  
of Reliability”

[www.hoshizaki.com](http://www.hoshizaki.com)

## SERVICE MANUAL



Number: 73175  
Issued: 12-15-2009  
Revised: 1-26-2012

**IMPORTANT**

Only qualified service technicians should attempt to install, service, or maintain this icemaker. No service or maintenance should be undertaken until the technician has thoroughly read this Service Manual. Failure to service and maintain the equipment in accordance with this manual may adversely affect safety, performance, and warranty coverage.

Hoshizaki provides this manual primarily to assist qualified service technicians in the service and maintenance of the icemaker.

Should the reader have any questions or concerns which have not been satisfactorily addressed, please call, write, or send an e-mail message to the Hoshizaki Technical Support Department for assistance.

HOSHIZAKI AMERICA, INC.  
618 Highway 74 South  
Peachtree City, GA 30269

Attn: Hoshizaki Technical Support Department

Phone: 1-800-233-1940 Technical Service  
(770) 487-2331  
Fax: 1-800-843-1056  
(770) 487-3360

E-mail: techsupport@hoshizaki.com

Web Site: www.hoshizaki.com

NOTE: To expedite assistance, all correspondence/communication MUST include the following information:

- Model Number \_\_\_\_\_
- Serial Number \_\_\_\_\_
- Complete and detailed explanation of the problem.

## IMPORTANT

This manual should be read carefully before the icemaker is serviced or maintenance operations are performed. Only qualified service technicians should install, service, and maintain the icemaker. Read the warnings contained in this booklet carefully as they give important information regarding safety. Please retain this booklet for any further reference that may be necessary.

## CONTENTS

I. Specifications.....	5
A. Icemaker .....	5
1. DCM-230HE-UK.....	5
2. DCM-230HE-CT .....	6
II. General Information.....	7
A. Construction.....	7
B. Ice Making Unit .....	8
C. Sequence of Operation .....	9
1. Sequence Cycles and Shutdown .....	9
a) Fill Cycle .....	9
b) Ice Purge Cycle (60 seconds).....	9
c) Freeze Cycle.....	9
d) Shutdown .....	9
2. Sequence Flow Chart.....	10
D. Control Board .....	11
1. Control Board Layout .....	12
2. Features.....	13
3. Controls and Adjustments .....	13
4. Control Board Check Procedure .....	14
E. Float Switch.....	15
III. Technical Information.....	16
A. Water Circuit and Refrigeration Circuit .....	16
B. Wiring Diagrams.....	17
C. Sequence of Electrical Circuit – Ice Making.....	18
1. Fill Cycle .....	18
2. Ice Purge Cycle .....	19
3. Freeze Cycle .....	20
4. Shutdown.....	21
5. Low Water Safety .....	22
6. High Pressure Switch .....	23
D. Sequence of Electrical Circuit – Dispensing .....	24
1. Continuous Dispense .....	24
2. Portion Dispense .....	25
IV. Service Diagnosis.....	26
A. Diagnostic Procedure .....	26
B. Ice Production Check .....	27
C. Diagnostic Charts .....	28
1. No Ice Production.....	28
2. Low Ice Production .....	31

3. Other.....	32
4. Dispensing.....	33
V. Removal and Replacement of Components .....	35
A. Service for Refrigerant Lines.....	35
1. Refrigerant Recovery .....	35
2. Brazing .....	35
3. Evacuation and Recharge (R-404A).....	36
B. Removal and Replacement of Compressor.....	37
C. Removal and Replacement of Expansion Valve.....	38
D. Removal and Replacement of Evaporator Assembly Components .....	39
1. Upper Bearing Wear Check .....	40
2. Removal and Replacement of Extruding Head.....	40
3. Removal and Replacement of Auger .....	41
4. Removal and Replacement of Evaporator .....	41
5. Removal and Replacement of Mechanical Seal and Lower Housing .....	42
6. Removal and Replacement of Gear Motor .....	43
E. Removal and Replacement of Air-Cooled Condenser.....	45
F. Removal and Replacement of Fan Motor.....	45
G. Removal and Replacement of Inlet or Dispensing Water Valve .....	46
H. Removal and Replacement of Drain Valve.....	47
I. Removal and Replacement of Dispensing System.....	47
1. Dispensing Auger and Agitator .....	47
2. Dispensing or Agitating Motor.....	48
VI. Cleaning and Maintenance.....	49
A. Cleaning and Sanitizing Instructions .....	49
1. Water System .....	50
a) Cleaning Solution .....	50
b) Cleaning Procedure .....	50
c) Sanitizing Solution .....	51
d) Sanitizing Procedure - Following Cleaning Procedure .....	51
2. Dispensing Components .....	51
a) Cleaning Solution .....	51
b) Sanitizing Solution.....	51
c) Cleaning & Sanitizing Procedure .....	52
B. Maintenance.....	53
C. Preparing the Icemaker for Long Storage .....	54

# I. Specifications

## A. Ice maker

### 1. DCM-230HE-UK

AC SUPPLY VOLTAGE	230/50/1
AMPERAGE	5.3 A (AT 32°C/WT 21°C)
STARTING AMPERAGE	18.6 A
ELECTRIC CONSUMPTION	815 W (AT 32°C/WT 21°C)
POWER FACTOR	67%
ELECTRIC CAPACITY	1.5 kVA
APPROXIMATE ICE PRODUCTION PER 24 HR.	230 kg (AT 10°C/WT 10°C) 190 kg (AT 21°C/WT 15°C) 150 kg (AT 32°C/WT 21°C)
SHAPE OF ICE	Cubelet (Compressed Flake Ice)
ICE QUALITY	Apprx. 90% Ice (32/21°C, CONDUCTIVITY 200 µs/cm)
APPROXIMATE STORAGE CAPACITY	18 kg
WATER CONSUMPTION PER 24 HR.	0.230 m <sup>3</sup> (AT 10°C/WT 10°C) 0.190 m <sup>3</sup> (AT 21°C/WT 15°C) 0.150 m <sup>3</sup> (AT 32°C/WT 21°C)
EXTERIOR DIMENSIONS (WxDxH)	660 x 571 x 1016 mm
EXTERIOR FINISH	Stainless Steel, Galvanized Steel (Rear)
WEIGHT	Net 108 kg
CONNECTIONS - ELECTRIC	Y-type connection (with UK plug)
- WATER SUPPLY	Inlet 1/2" FPT
- DRAIN	Drain Pan 3/4" FPT Bin Drain 3/4" FPT
ICE MAKING SYSTEM	Auger type
HARVESTING SYSTEM	Direct Driven Auger ( 125 W Gear Motor )
ICE MAKING WATER CONTROL	Float Switch
ICE DISPENSING SYSTEM	Shutter connected to solenoid controlled by Push Button (Agitator revolution) Continuous or Portion (1~30sec) Dispensing mode Change Switch
WATER DISPENSING SYSTEM	Water Valve controlled by Push Button
BIN CONTROL SYSTEM	Mechanical Bin Control ( Proximity Sw. )
COMPRESSOR	Hermetic 495 W, Model SC12DL
CONDENSER	Air-cooled, Fin and tube type
EVAPORATOR	Copper Tube on Cylinder
REFRIGERANT CONTROL	Thermostatic Expansion Valve
REFRIGERANT CHARGE	R404A 530g
MAX OPERATING PRESSURE	2.88 MPa
ELECTRICAL PROTECTION	Class I Appliance IPX2 10A Fuse, 13A Fuse built in UK plug
COMPRESSOR PROTECTION	Auto-reset Overload Protector
GEAR MOTOR PROTECTION	Manual Reset Circuit Breaker
REFRIGERANT CIRCUIT PROTECTION	Auto-reset High Pressure Control Switch
LOW WATER PROTECTION	Float Switch and Timer
PACKAGE DIMENSIONS (WxDxH)	810mm x 680mm x 1152mm
PACKING WEIGHT	120kg (Gross)
ACCESSORIES	Mounting Bracket, Inlet and Outlet Hose, Spare Fuse, Nipple
OPERATING CONDITIONS	VOLTAGE RANGE Rated Voltage ±10% AMBIENT TEMP. 5~40°C WATER SUPPLY TEMP. 5~35°C WATER SUPPLY PRESSURE 0.5~8bar (0.05~0.8MPa)

Note: We reserve the right to make changes in specifications and design without prior notice.

# Data Pending

Note: We reserve the right to make changes in specifications and design without prior notice.

## II. General Information

### A. Construction

#### 1. DCM-230HE-UK, DCM-230HE-CT

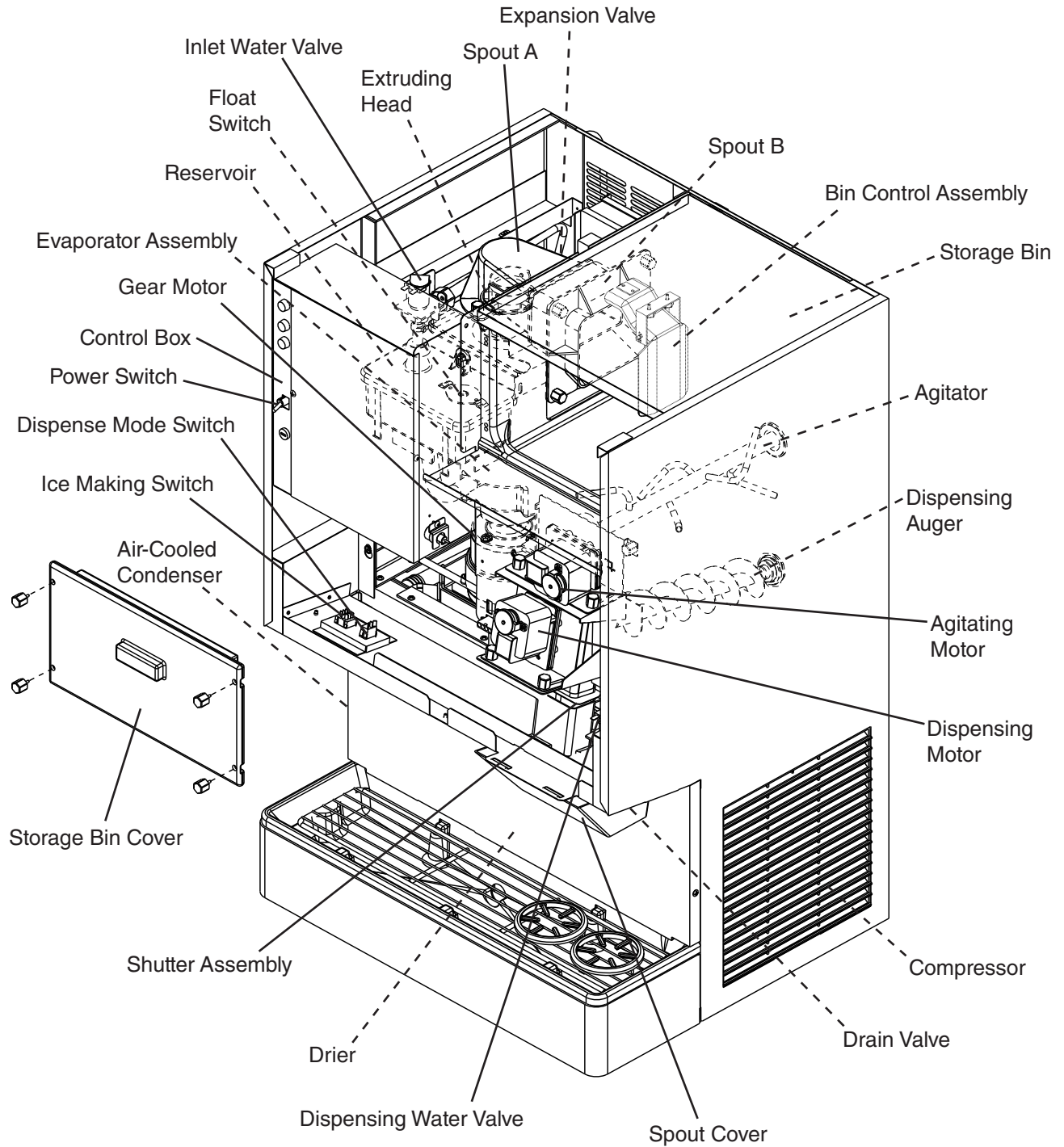

## B. Ice Making Unit

### 1. DCM-230HE-UK, DCM-230HE-CT

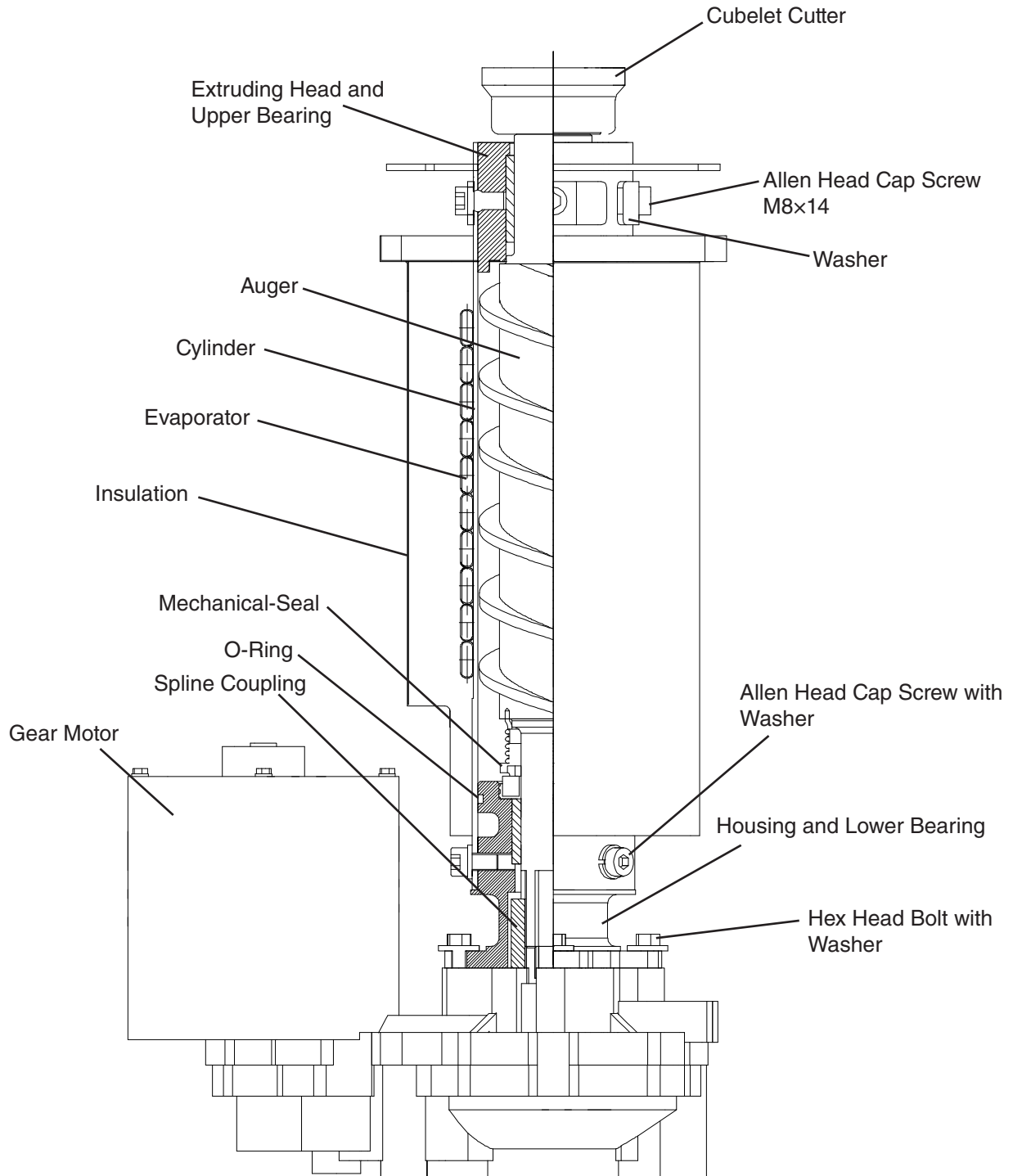



## C. Sequence of Operation

### 1. Sequence Cycles and Shutdown

The steps in the sequence are as outlined below. When power is supplied, the power switch is in the "ON" position, and the ice making switch is in the "ICE" position, the "POWER" LED on the control board comes on.

#### a) *Fill Cycle*

WV opens and the reservoir fills with water until UF/S closes. Note: GM will not start unless UF/S is closed. For details, see "IV. Service Diagnosis".

#### b) *Ice Purge Cycle (60 seconds)*

"GM" LED is on. WCR energizes, closing the low water safety circuit and de-energizing the WV. GM and GMPR energize. GM runs for 60 seconds to clear any ice from the evaporator.

#### c) *Freeze Cycle*

"COMP", "GM" LEDs are on. Comp and FM energize. As the water in the evaporator cools, ice starts forming within 4 to 6 minutes. This time frame depends on the inlet water and ambient temperature conditions. UF/S and LF/S operate WV as needed to continue the ice making process. This continues until BC shuts the icemaker down or power is turned off to the icemaker.

#### d) *Shutdown*

BC is activated and a 150 second shutdown sequence begins. After BC has been open for 90 seconds, Comp and FM de-energize, AM energizes for 0.6 seconds, and 60 seconds later GM de-energizes.

Legend: **AM**—agitating motor; **BC**—bin control; **Comp**—compressor; **FM**—fan motor;  
**GM**—gear motor; **GMPR**—gear motor protect relay;  
**LF/S**—lower float switch; **UF/S**—upper float switch; **WCR**—water control relay;  
**WV**—inlet water valve

# DCM-230HE-UK, DCM-230HE-CT Sequence Flow Chart and Component Operation

## 2. Sequence Flow Chart

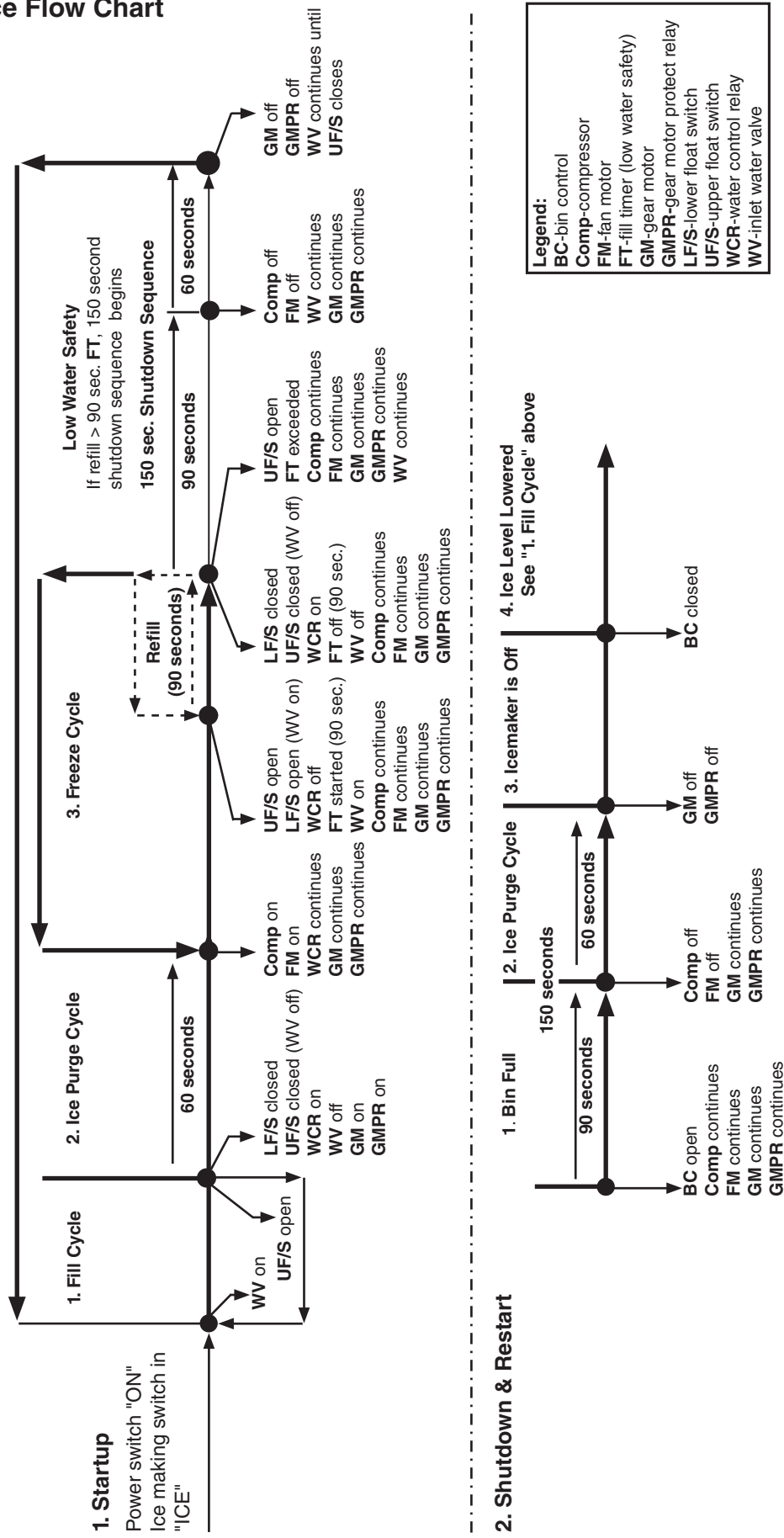

### 2. Shutdown & Restart

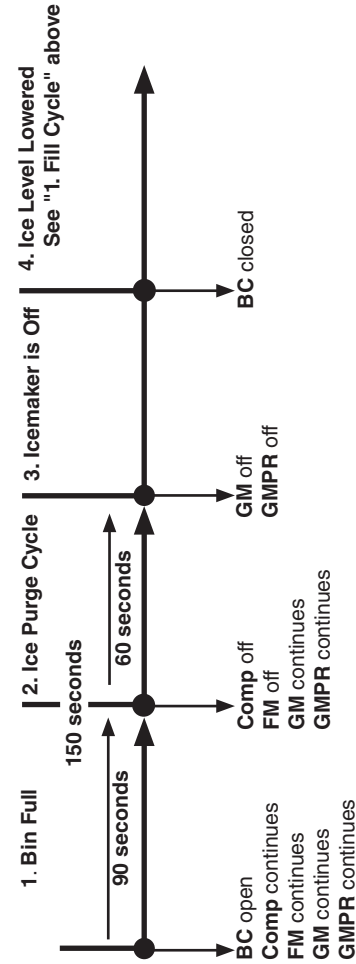

## D. Control Board

- A Hoshizaki exclusive solid-state control board is employed in DCM-230HE-UK and DCM-230HE-CT Cubelet Ice maker / Dispensers.
- All models are pretested and factory-adjusted.

### CAUTION

1. Fragile, handle very carefully.
2. The control board contains integrated circuits, which are susceptible to failure due to static discharge. It is especially important to touch the metal part of the unit before handling or replacing the board.
3. Do not touch the electronic devices on the control board or the back of the control board to prevent damage to the control board.
4. Do not change wiring and connections. Especially, never misconnect terminals.
5. Always replace the whole control board if it goes bad.
6. Do not short out power supply to test for voltage.

# 1. Control Board Layout

## a) DCM-230HE-UK, DCM-230HE-CT

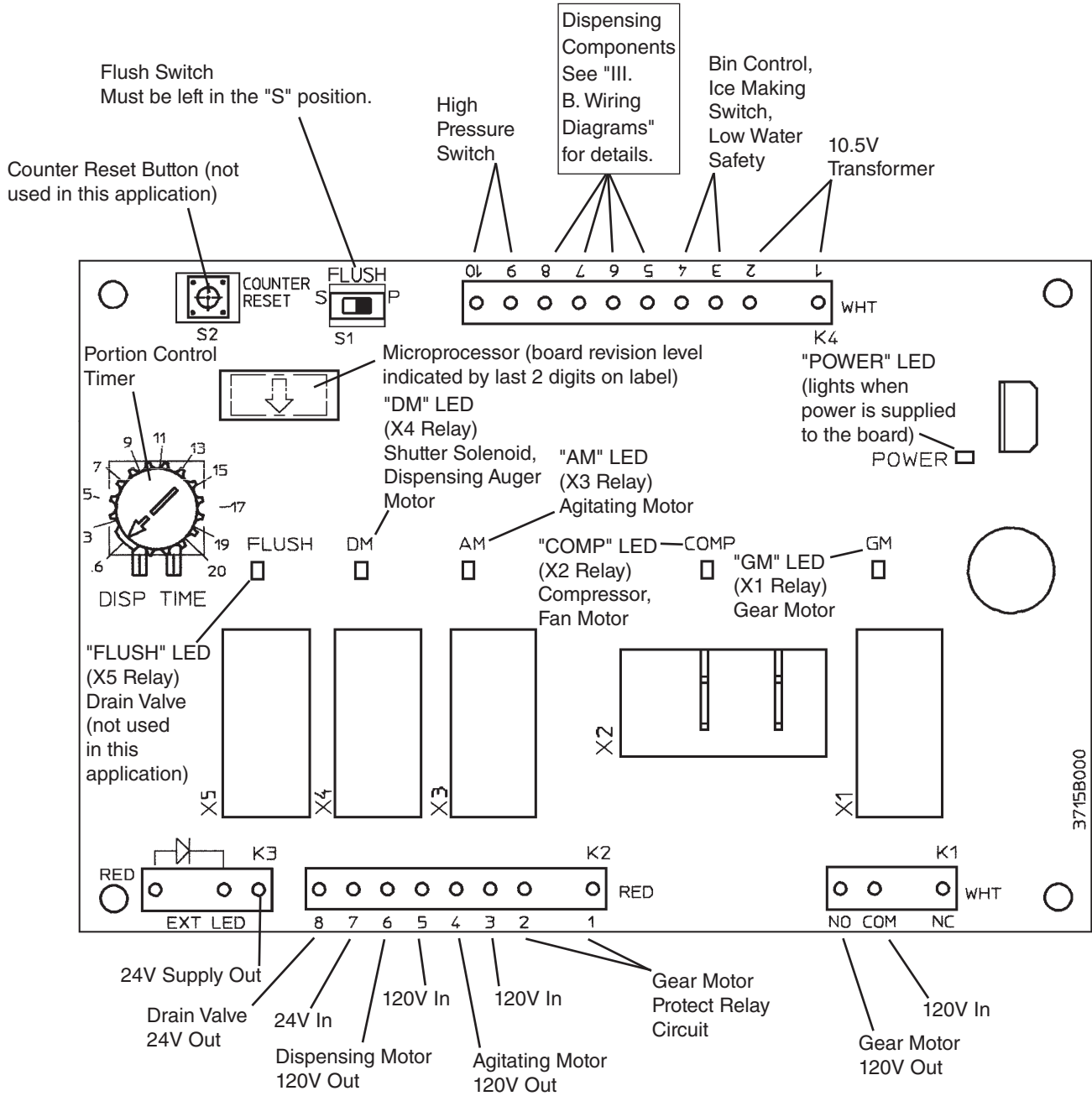

Control Board	
Part Number	2A1592-01

## 2. Features

The control board provides the following safeguards:

- Provides component protection during low water supply.
- Purges remaining ice in the evaporator at startup and shutdown.
- Provides short cycle protection for the compressor.

### a) LED Lights

The "POWER" LED indicates control voltage and will remain on unless a control voltage problem occurs. An LED illuminates for each relay as it is energized. For more information, see "II.C. Sequence of Operation."

Icemaking				
Cycle (Relay)	LED	Energized Components	Time LEDs are On	Frequency LEDs are On
Fill	POWER only	WV	N/A	As Needed
Ice Purge (X1)	GM	GM	60 seconds	N/A
Freeze (X1, X2)	GM, COMP	GM, Comp, FM	N/A	N/A

Dispensing				
Relay	LED	Energized Component	Time LEDs are On	Frequency LEDs are On
Ice Dispense (X4)	Push Button DM	IDM	60 seconds maximum	N/A
	Opti Serv ICE			
Agitating Motor (X3)	AM	AM	.6 seconds	Every 12 seconds of accumulative dispense time

Legend: **AM**—agitating motor, **Comp**—compressor; **FM**—fan motor; **GM**—gear motor; **IDM**—ice dispensing motor, shutter solenoid; **WTR**—dispensing water valve; **WV**—inlet water valve

## 3. Controls and Adjustments

### a) Portion Control

When the dispense mode switch is placed in the "PORTION" position, a variable resistor (located on the control board) controls the ice dispense time.

The figures on the label indicate dispensing time (sec.). When shipped, the portion control is set at the minimum dispensing time (0.6 sec.).

DCM-230HE-UK, DCM-230HE-CT. . . . . Approximately 0.72 oz.

Amount of ice dispensed per second.

DCM-230HE-UK, DCM-230HE-CT . . . . . Approximately 1.2 oz.

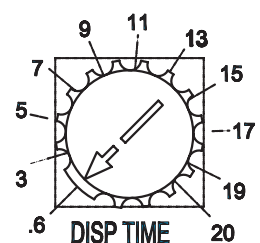

#### **4. Control Board Check Procedure**

Before replacing a control board that does not show a visible defect and that you suspect is bad, always conduct the following check procedure. This procedure will help you verify your diagnosis.

##### **a) Power Supply**

1. Move the ice making switch to the "ICE" position. The "POWER" LED should come on. If the "POWER" LED is off, check that the unit is plugged in, the power supply is on, the power switch is in the "ON" position, and the ice making switch is in the "ICE" position. Check the fuses and the control transformer secondary circuit. Control transformer output is 10.5V at 120V primary input. If the 10.5V secondary circuit (K4 pins 1 and 2) has proper voltage and the "POWER" LED is off, the control board is bad and must be replaced.

If the control transformer secondary circuit does not have proper voltage, check the main transformer secondary circuit. Check for 120V at the control board K2 connector. Check the #3 pin (BK wire) to a white neutral wire for 120V. Always choose a white neutral wire to establish a good neutral connection when checking voltages. For additional checks, see "IV.C.1.[1] The icemaker will not start (Fill Cycle)."

##### **b) Ice Making Components**

1. Confirm the reservoir is full of water. If no water is in the reservoir, make sure that the drain valve is closed. Also check the water supply line, water shutoff valve, and water filters. In the fill cycle, the "POWER" LED is the only LED lit on the control board. If no water is filling the reservoir, check for 24V at connector K2 terminal 7 to neutral and connector K3 (DBU) to neutral. If there is 24V at connector K2 terminal 7 to neutral and no voltage at K3 (DBU) to neutral, the control board is bad and must be replaced. See "IV.C.1.[1] The icemaker will not start (Fill Cycle)" for further details.
2. When the reservoir is full, the "GM" LED comes on and the gear motor starts. If the "GM" LED does not come on or the gear motor does not start, check that the following safety circuits are closed: a) high pressure switch (connector K4 terminals 9 and 10), b) low water safety/bin control/ice making switch circuit (connector K4 terminals 3 and 4). Next, check for 120V at connector K1 "COM" and K1 "NO" on the control board to neutral. If the "GM" LED is on and there is voltage at K1 "COM" to neutral and no voltage at K1 "NO" to neutral, the control board is bad and must be replaced. See wiring diagram "III.C.2. Ice Purge Cycle" for further details.
3. 60 seconds after the "GM" LED comes on, the "COMP" LED comes on, and the compressor and fan motor start. If the "COMP" LED does not come on 60 seconds after the gear motor starts, check that the gear motor protect relay contacts (connector K2 terminals 1 and 2) have closed. If the "COMP" LED is on and the compressor and fan motor did not start, check for 120V at X2 (LBU) and X2 (BR) on the control board to neutral. If the "COMP" LED is on and there is voltage at X2 (BR) to neutral and no voltage at X2 (LBU) to neutral, the control board is bad and must be replaced. See wiring diagram "III.C.3. Freeze Cycle" for further details.

### c) Dispensing Components

1. Ice Dispense "Continuous": Pressing the ice dispense switch closes terminals 6 and 5 at the K4 connector. The "DM" LED comes on and the dispensing motor energizes. If the "DM" LED does not turn on, check continuity through the ice dispense switch and the dispense mode switch. If the LED is on and the dispensing motor does not start, check for 120V at connector K2 terminals 3 and 6 to a neutral. With voltage at terminal 3 and not at terminal 6, the control board is bad and must be replaced.

Note: The agitating motor will operate .6 seconds every 12 seconds of accumulative dispense time. See "III.D.1. Continuous Dispense."

2. Ice Dispense "Portion": Pressing the ice dispense switch closes terminals 6 and 7 at the K4 connector. The "DM" LED comes on and the dispensing motor energizes. If the "DM" LED does not turn on, check continuity through the ice dispense switch and the dispense mode switch. If the LED is on and the dispensing motor does not start, check for 120V at connector K2 terminals 3 and 6 to a neutral. With voltage at terminal 3 and not at terminal 6, the control board is bad and must be replaced.

Note: The agitating motor will operate .6 seconds every 12 seconds of accumulative dispense time. See "III.D.2. Portion Dispense."

### E. Float Switch

Depending on local water conditions, scale may build up on the float switch. Scale on the switch can cause the floats to stick. In this case, the float switch should be cleaned and checked.

First, remove the switch from the water tank. Soak the switch assembly in a mixture of 1 part recommended cleaner Hoshizaki "Scale Away" and 25 parts warm water. While not necessary, the floats can be removed from the shaft during cleaning. If you remove them, note that the blue float is on top. The floats must be installed with the magnets inside them towards the top of the switch. Installing the floats upside down will affect the timing of the float switch operation. Once clean, rinse the parts thoroughly with clean water. Next, check the switch with an ohm meter. This float switch has three wires (the black wire is common) and two separate switches. Check the upper switch by ohming out the black and red wires. When the float is up, the switch should be closed. Check the lower switch by ohming out the black and blue wires in the same manner. If either switch fails, the assembly must be replaced.

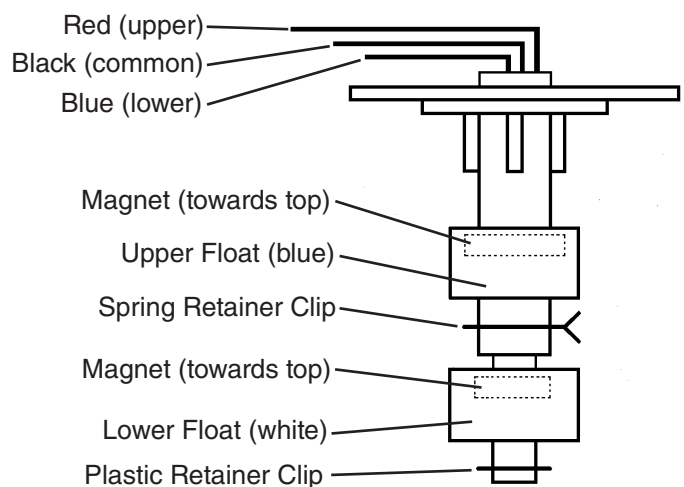

### III. Technical Information

#### A. Water Circuit and Refrigeration Circuit

##### 1. DCM-230HE-UK, DCM-230HE-CT

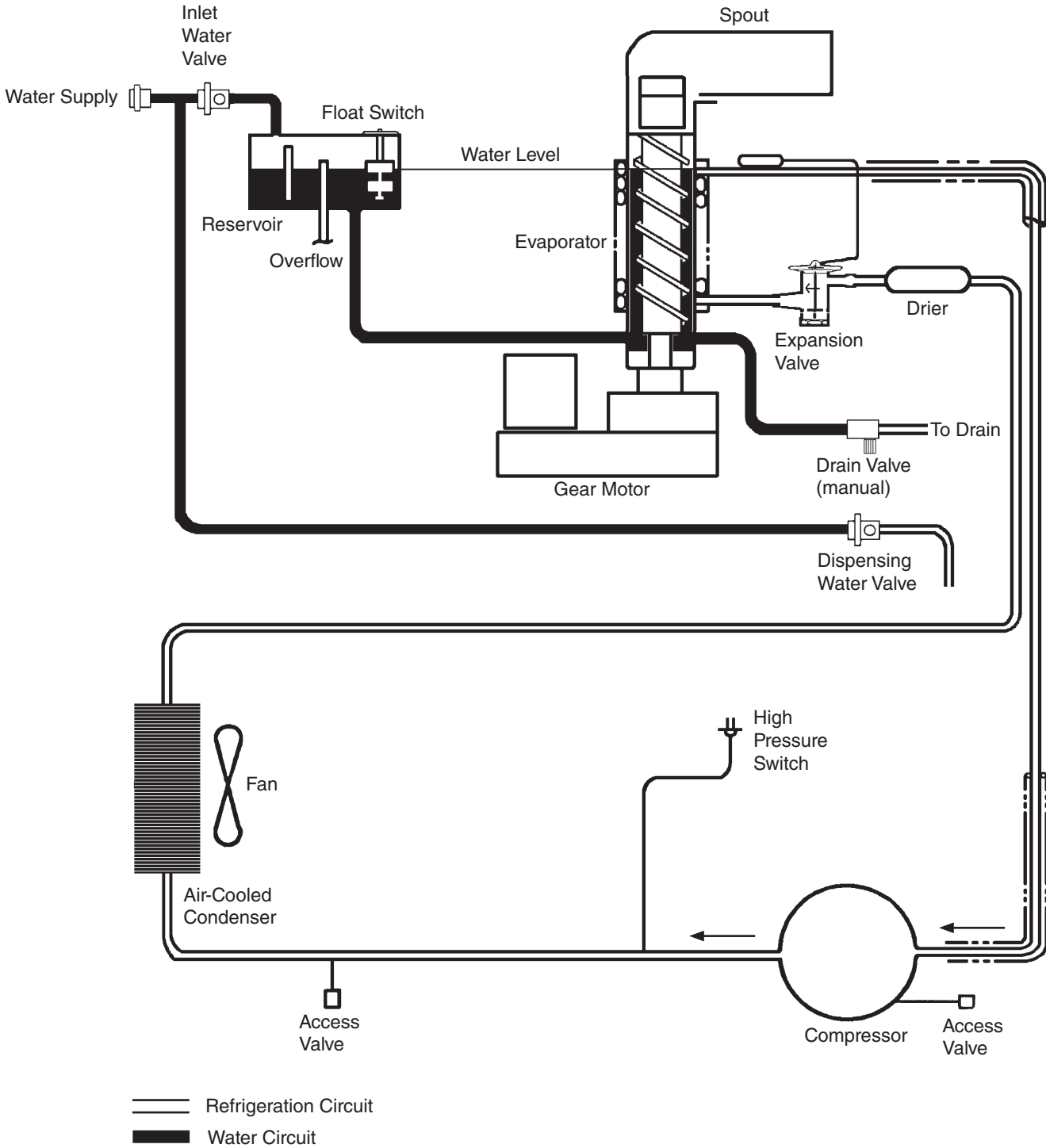



## B. Wiring Diagrams

### 1. DCM-230HE-UK, DCM-230HE-CT

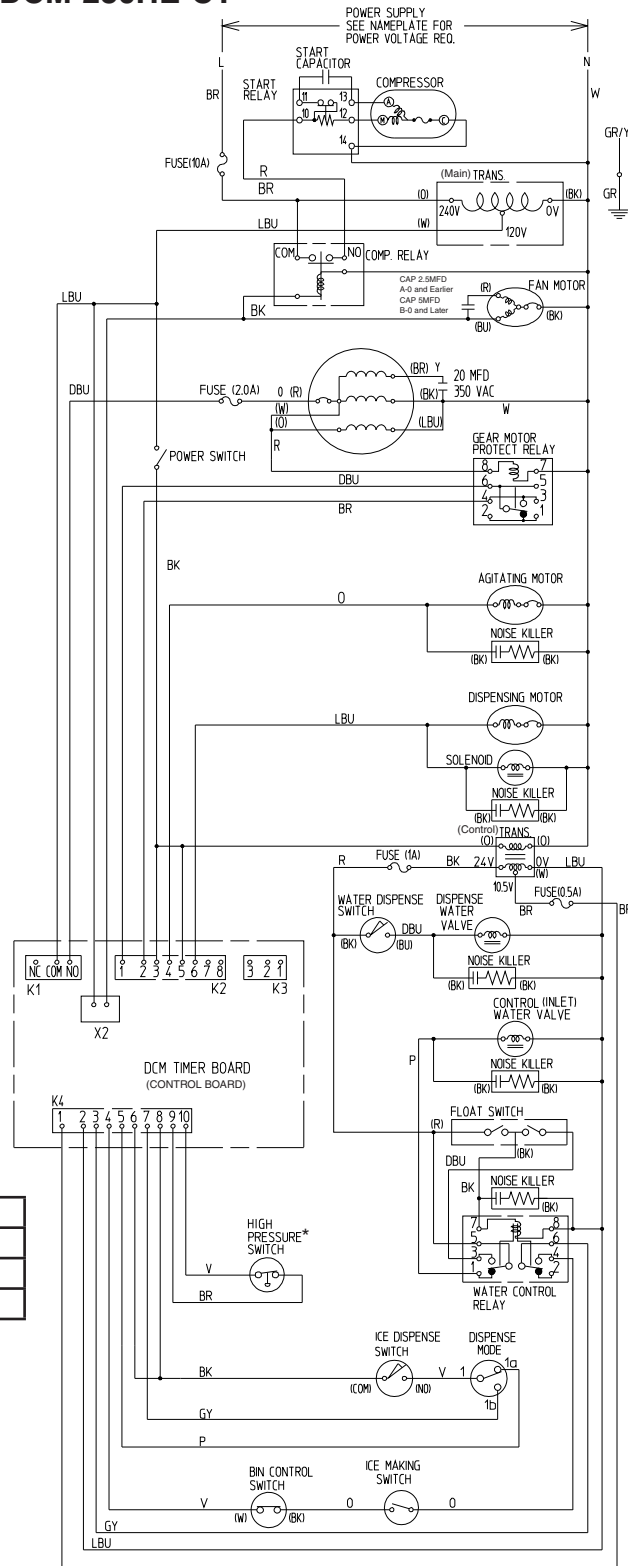

* High Pressure Switch	
Air-Cooled Model	
Cut-out	412±21 PSIG
Cut-in	327±21 PSIG

#### WIRE COLOR CODE

BK	BLACK	LBU	LIGHT BLUE
BR	BROWN	O	ORANGE
BU	BLUE	P	PINK
DBU	DARK BLUE	R	RED
GR	GREEN	V	VIOLET
GR/Y	GREEN/YELLOW	W	WHITE
GY	GRAY	Y	YELLOW

# C. Sequence of Electrical Circuit – Ice Making

## 1. Fill Cycle

With the power switch in the "ON" position and the ice making switch in the "ICE" position, the inlet water valve energizes and the reservoir fills with water until the upper float switch closes.

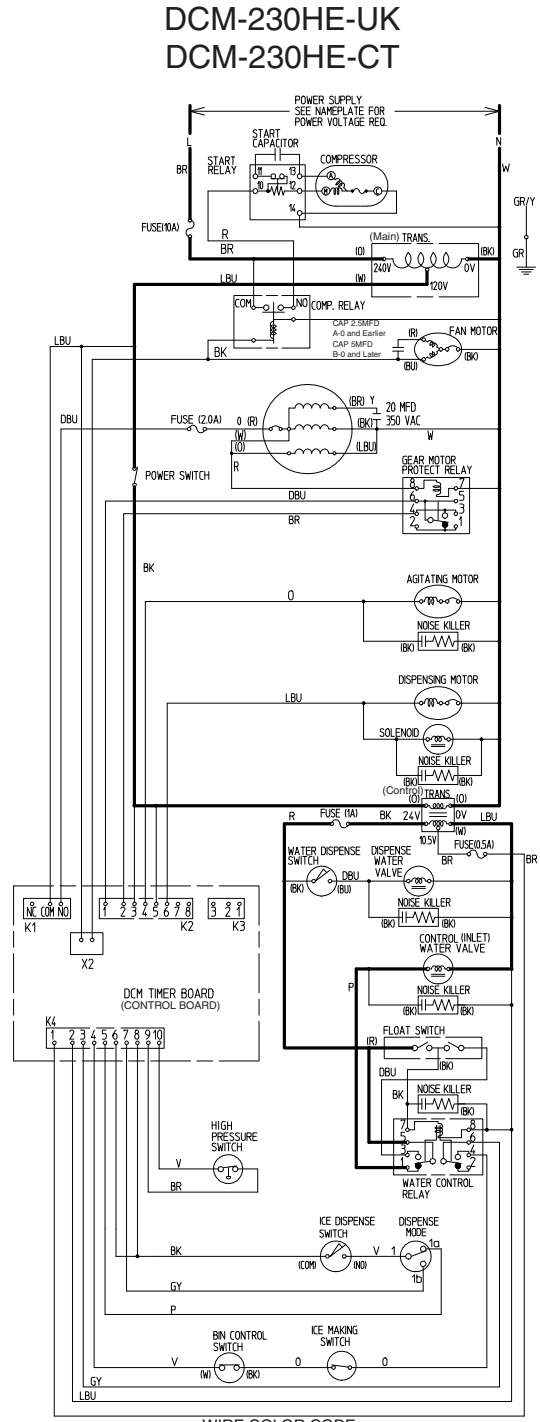

WIRE COLOR CODE

BK	BLACK	LBU	LIGHT BLUE
BR	BROWN	O	ORANGE
BU	BLUE	P	PINK
DBU	DARK BLUE	R	RED
GR	GREEN	V	VIOLET
GR/Y	GREEN/YELLOW	W	WHITE
GY	GRAY	Y	YELLOW

## 2. Ice Purge Cycle

Upper float switch closes, water control relay energizes, inlet water valve closes, gear motor starts, gear motor protect relay energizes.

### DCM-230HE-UK DCM-230HE-CT

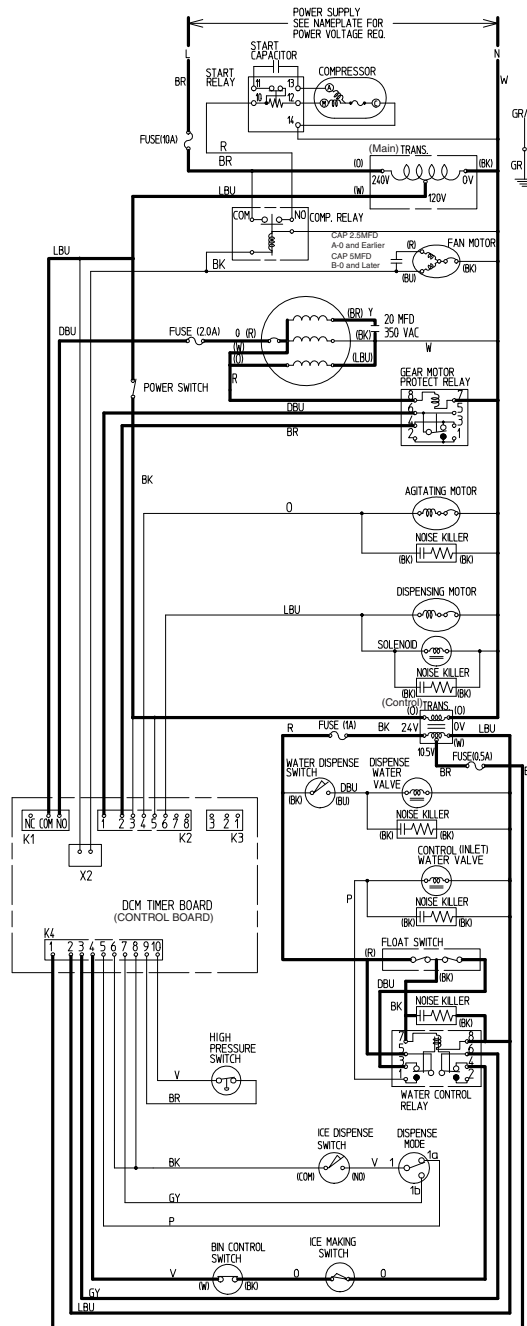

#### WIRE COLOR CODE

BK	BLACK	LBU	LIGHT BLUE
BR	BROWN	O	ORANGE
BU	BLUE	P	PINK
DBU	DARK BLUE	R	RED
GR	GREEN	V	VIOLET
GR/Y	GREEN/YELLOW	W	WHITE
GY	GRAY	Y	YELLOW



#### 4. Shutdown

The bin control switch is activated and a 150 second shutdown sequence begins. After the bin control has been open for 90 seconds, the compressor and fan motor stop, the agitating motor operates for 0.6 seconds, and 60 seconds later the gear motor stops.

### DCM-230HE-UK DCM-230HE-CT

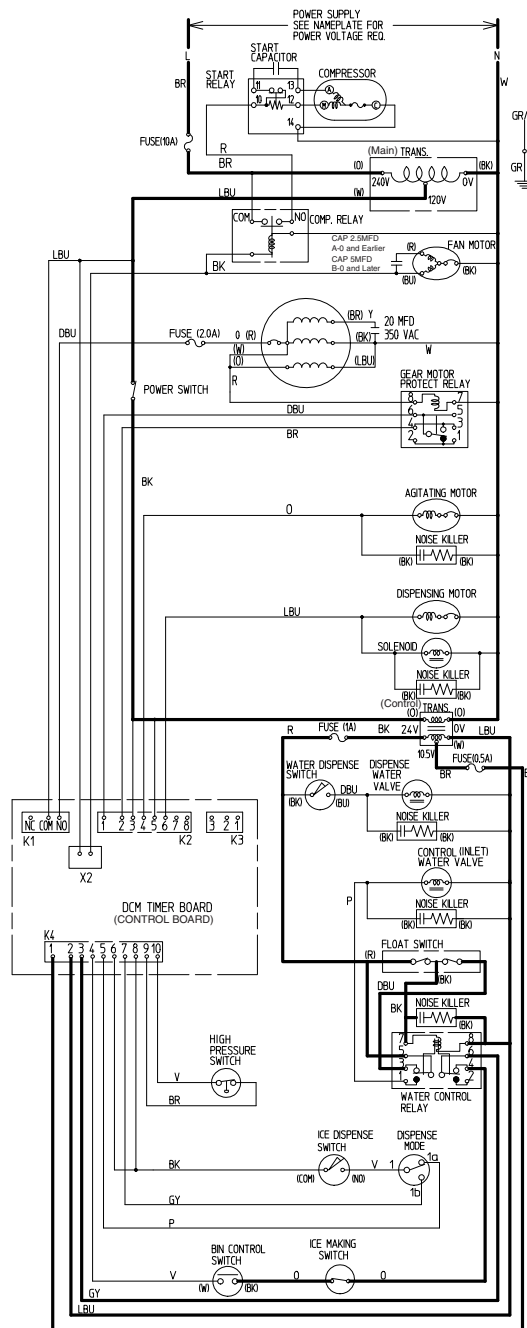

WIRE COLOR CODE

BK	BLACK	LBU	LIGHT BLUE
BR	BROWN	O	ORANGE
BU	BLUE	P	PINK
DBU	DARK BLUE	R	RED
GR	GREEN	V	VIOLET
GR/Y	GREEN/YELLOW	W	WHITE
GY	GRAY	Y	YELLOW

## 5. Low Water Safety

Upper float switch fails to close within 90 seconds after the lower float switch opens, the 150 second shutdown sequence begins. The inlet water valve remains open until the upper float switch closes.

### DCM-230HE-UK DCM-230HE-CT

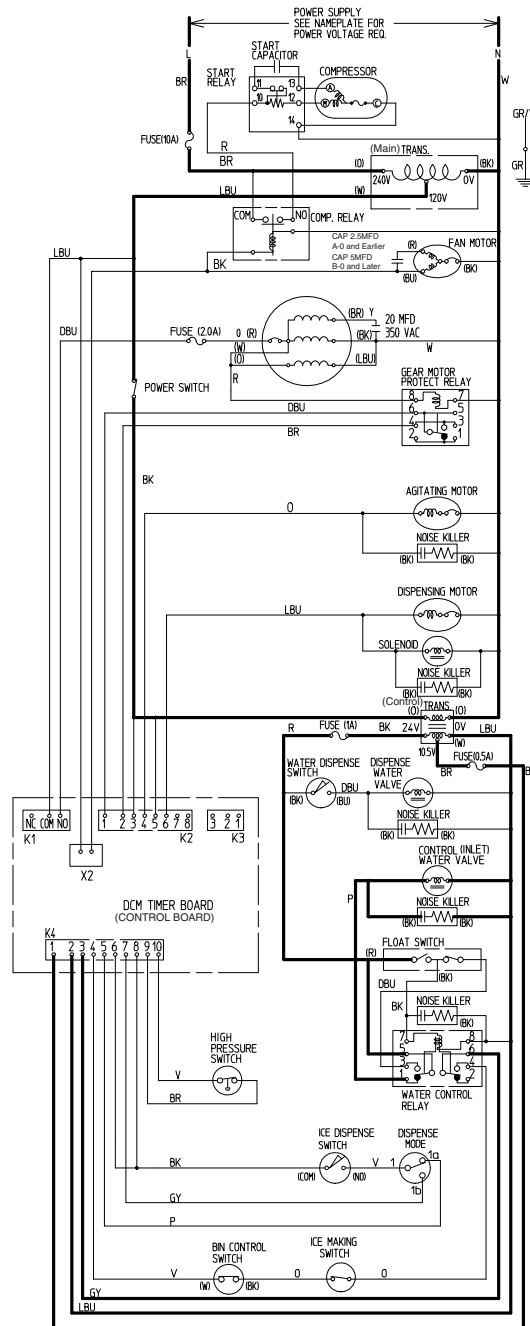

#### WIRE COLOR CODE

BK	BLACK	LBU	LIGHT BLUE
BR	BROWN	O	ORANGE
BU	BLUE	P	PINK
DBU	DARK BLUE	R	RED
GR	GREEN	V	VIOLET
GR/Y	GREEN/YELLOW	W	WHITE
GY	GRAY	Y	YELLOW

## 6. High Pressure Switch

When the high pressure switch opens, the compressor stops immediately, 60 seconds later the gear motor stops. To restart, allow time for the high pressure switch to close, then move the power switch to the "OFF" position and then back to the "ON" position.

### DCM-230HE-UK DCM-230HE-CT

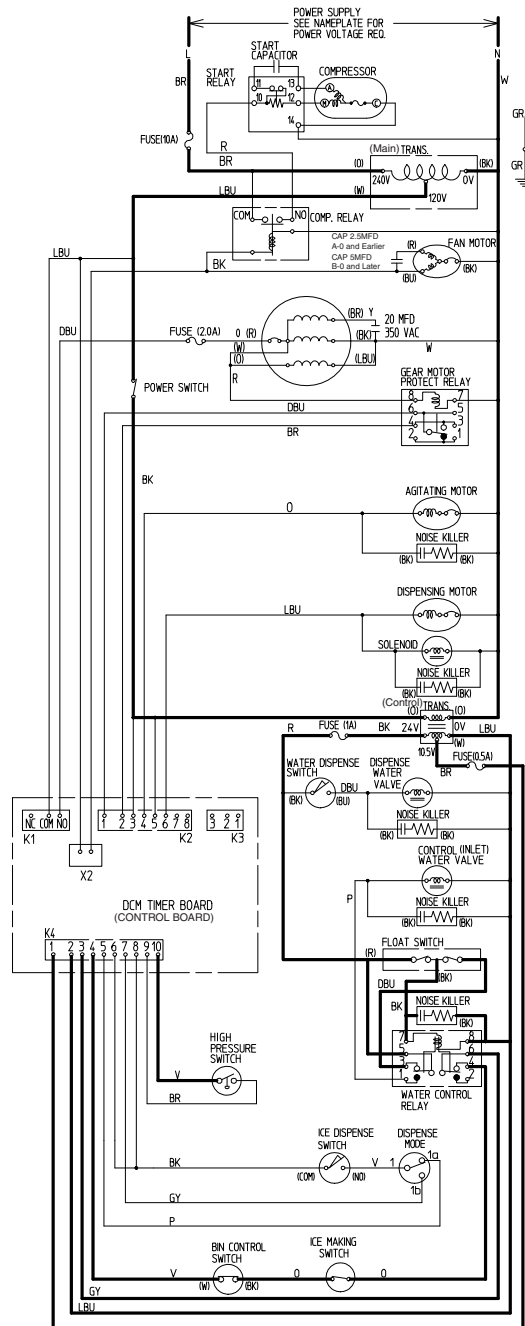

#### WIRE COLOR CODE

BK	BLACK	LBU	LIGHT BLUE
BR	BROWN	O	ORANGE
BU	BLUE	P	PINK
DBU	DARK BLUE	R	RED
GR	GREEN	V	VIOLET
GR/Y	GREEN/YELLOW	W	WHITE
GY	GRAY	Y	YELLOW

## D. Sequence of Electrical Circuit – Dispensing

### 1. Continuous Dispense

Agitating motor energizes for 0.6 seconds for every 12 seconds of accumulative dispense time. Maximum dispense time per dispense switch activation is 60 seconds. After 60 seconds, the dispense switch must be disengaged and engaged again.

### DCM-230HE-UK DCM-230HE-CT

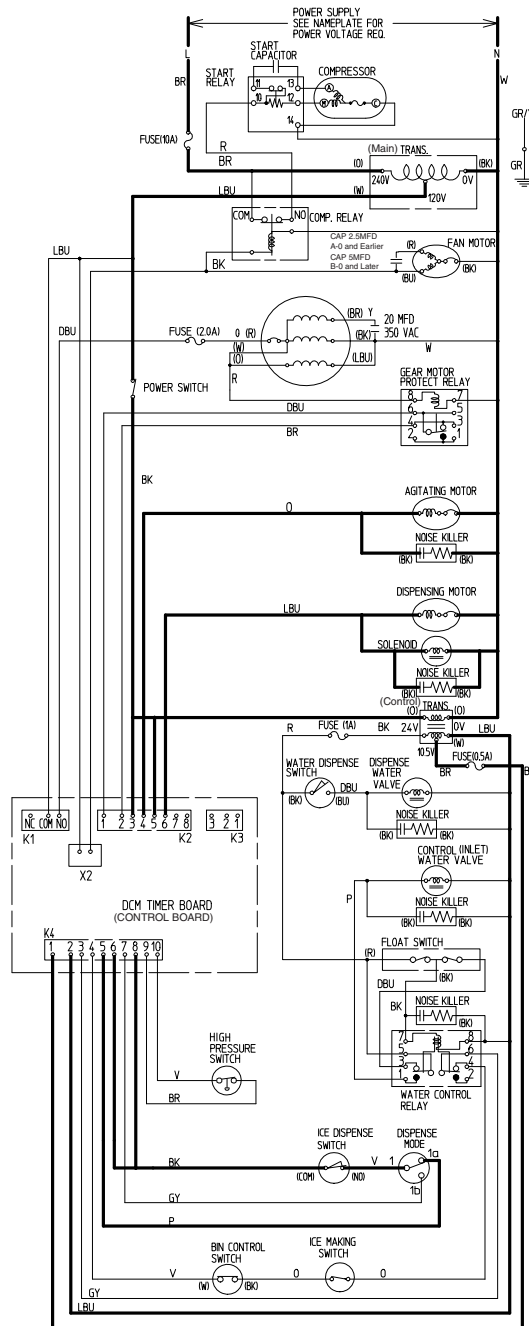

#### WIRE COLOR CODE

BK	BLACK	LBU	LIGHT BLUE
BR	BROWN	O	ORANGE
BU	BLUE	P	PINK
DBU	DARK BLUE	R	RED
GR	GREEN	V	VIOLET
GR/Y	GREEN/YELLOW	W	WHITE
GY	GRAY	Y	YELLOW



## 2. Portion Dispense

Agitating motor energizes for 0.6 seconds for every 12 seconds of accumulative dispense time. A variable resistor which controls the amount of ice dispensed is located on the control board. The figures on the label indicate dispensing time (sec.). See "II.D.3.a) Portion Control." When shipped, the portion control is set at the minimum dispensing time (0.6 sec.).

DCM-230HE-UK, DCM-230HE-CT ..... Approximately 0.72 oz.

Amount of ice dispensed per second.

DCM-230HE-UK, DCM-230HE-CT ..... Approximately 1.2 oz.

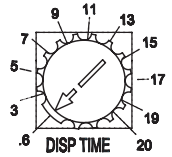

DCM-230HE-UK  
DCM-230HE-CT

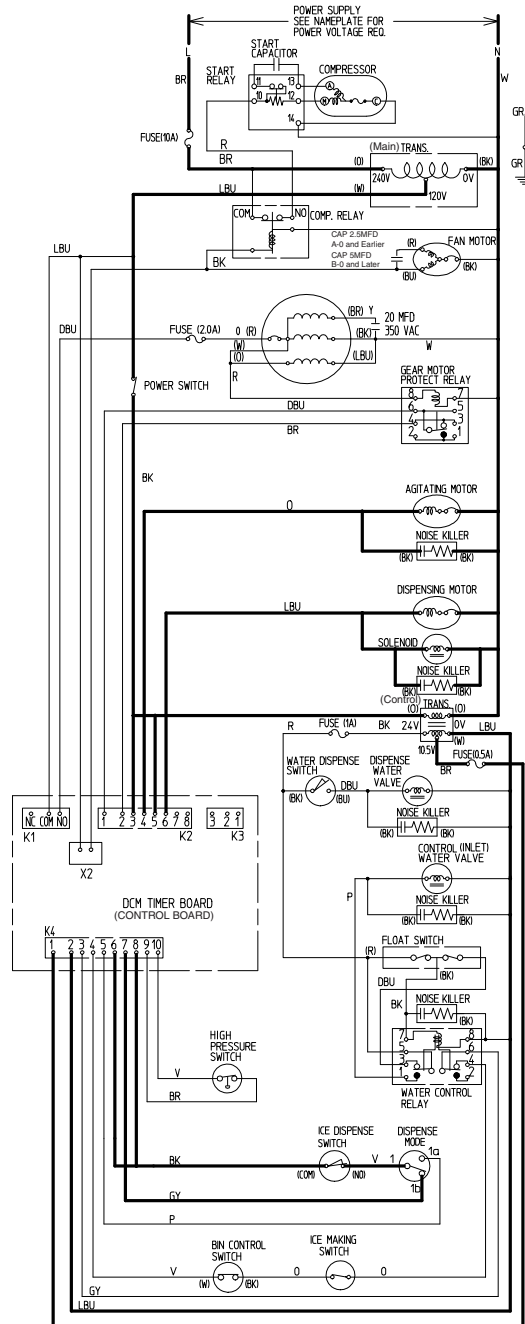

WIRE COLOR CODE

BK	BLACK	LBU	LIGHT BLUE
BR	BROWN	O	ORANGE
BU	BLUE	P	PINK
DBU	DARK BLUE	R	RED
GR	GREEN	V	VIOLET
GR/Y	GREEN/YELLOW	W	WHITE
GY	GRAY	Y	YELLOW

---

## IV. Service Diagnosis

### A. Diagnostic Procedure

This diagnostic procedure is a sequence check that allows you to diagnose the electrical system and components. Before proceeding, check for correct installation, adequate water supply (minimum of 10 PSIG, maximum of 113 PSIG) and proper voltage per unit nameplate. Always choose a white neutral wire to establish a good neutral connection when checking voltages. LEDs on the control board correspond to the components as they energize.

- 1) Move the ice making switch to the "OFF" position, then turn off the power supply. Remove the upper and lower front panels. Confirm the power switch is in the "ON" position.
- 2) Turn on the power supply, then move the ice making switch to the "ICE" position. The "POWER" LED is on. If the "POWER" LED is off, see "II.D.4. Control Board Check Procedure."
- 3) **Fill Cycle** – The inlet water valve energizes. The reservoir fills. The lower float switch closes. Nothing occurs at this time. The reservoir continues to fill until the upper float switch closes, energizing the water control relay, which closes the low water safety circuit and de-energizes the inlet water valve. **Diagnosis:** Check that the inlet water valve fills the reservoir. If not, check for water supply line shut-off valve closed, clogged water filters, clogged inlet water valve screen, drain valve open or leaking, power circuit to the inlet water valve (power switch, transformer, fuses, high pressure switch, bin control, ice making switch, float switch, water control relay contacts), and the coil on the inlet water valve. Check that the inlet water valve shuts off when the upper float switch closes. If not, check the float switch, water control relay, and inlet water valve.
- 4) **Ice Purge Cycle** – "GM" LED is on (60 second short cycle protection). The 60 second timer starts, the gear motor protect relay and gear motor energize. **Diagnosis:** Check that the gear motor starts. If not, check that the water control relay is energized (inlet water valve should be closed). Check the low water safety circuit on the water control relay (terminals 4 and 6), check for 120V at the K1 connector "COM" terminal to neutral and "NO" terminal to neutral on the control board (see wiring diagram), check the gear motor fuse (overload protector), thermal protector, gear motor capacitor, and motor windings. If the gear motor starts, but the auger does not turn, check the gear motor coupling between the auger and the gear motor. If the compressor starts at the same time the gear motor starts, check the X2 compressor relay on the control board.
- 5) **Freeze Cycle** – "GM", "COMP" LEDs are on. The compressor and fan motor energize, the gear motor protect relay, gear motor, and water control relay remain energized. Ice production begins 4 to 6 minutes after the compressor and fan motor start depending on ambient and water temperature conditions. **Diagnosis:** Check that the compressor and fan motor are running. If not, check for voltage on and to the compressor (X2 relay on the control board). Check that the gear motor protect relay circuit terminals 3 and 5 are closed, check the compressor internal overload (thermal protector), the compressor capacitors, fan capacitor, and voltage to the fan motor.

6) **Refill /Low Water Safety** – As ice is produced, the water level in the reservoir drops. As the water level drops, the upper and lower float switches open. First, the upper float switch opens. Nothing occurs at this time. When the lower float switch opens, refill begins. The water control relay de-energizes, the 90 second low water safety timer begins, and the inlet water valve energizes. The compressor, fan motor, and gear motor continue to run. When the upper float switch closes, the water control relay energizes, the 90 second low water safety timer terminates, and the inlet water valve de-energizes.

If the upper float switch fails to close within 90 seconds after the inlet water valve energizes, a 150 second shutdown sequence begins. 90 seconds after the 90 second low water safety timer is complete, the compressor and fan motor de-energize, 60 seconds later the gear motor de-energizes. The inlet water valve continues until the upper float switch closes. **Diagnosis** – Check that the reservoir fills. If not, check the water supply line, clogged water filters, dirty or sticking float switches, inlet water valve screen, water control relay contacts, voltage to the inlet water valve, and inlet water valve solenoid or drain valve leaking.

7) **Shutdown** – The bin fills and activates the bin control. A 150 second shutdown sequence begins. After the bin control has been open for 90 seconds, the compressor and fan motor stop, the agitating motor energizes for 0.6 seconds, and 60 seconds later the gear motor stops. **Diagnosis:** Check that the bin control paddle is activated and that the bin control switch opens. If the compressor and gear motor fail to stop, check the bin control (proximity) switch and control board relays.

## **B. Ice Production Check**

To check production, prepare a bucket or pan to catch the ice and a set of scales to weigh the ice. After the icemaker has operated for 10 to 20 minutes, catch the ice production for 10 minutes. Weigh the ice to establish the batch weight. Multiply the batch weight by 144 for the total production in 24 hours.

## C. Diagnostic Charts

### 1. No Ice Production

Problem	Possible Cause	Remedy	
[1] The icemaker will not start. (Fill Cycle)	a) Power Supply	1. Unplugged, off, blown fuse, or tripped breaker.	1. Plug in, turn on, replace, or reset.
		2. Loose connection.	2. Tighten.
		3. Bad contacts.	3. Check for continuity and replace.
		4. Not within specifications.	4. Refer to nameplate and correct.
	b) Water Supply	1. Water supply off or pressure too low.	1. Check and get recommended pressure.
	c) Power Switch (Control Box)	1. "OFF" position.	1. Move to "ON" position.
		2. Bad contacts.	2. Check for continuity and replace.
	d) Main and/or Control Transformer	1. Coil winding open.	1. Replace.
	e) Fuses	1. Blown.	1. Check for short circuit and replace.
	f) Ice Making Switch	1. "OFF" position.	1. Move to "ICE" position.
		2. Bad contacts.	2. Check for continuity and replace.
	g) Water Control Relay	1. Bad contacts.	1. Check for continuity and replace.
		2. Coil winding open.	2. Replace.
	h) Inlet Water Valve	1. Mesh filter or orifice clogged.	1. Clean.
		2. Coil winding open.	2. Replace.
		3. Wiring to inlet water valve.	3. Check for loose or open connection. Repair or replace.
	i) Float Switch	1. Bad contacts.	1. Check for continuity and replace.
		2. Float does not move freely.	2. Clean or replace.
	j) Bin Control	1. Open.	1. Bin full, check for continuity on proximity switch.
		2. Actuator sticking.	2. Adjust or replace.
		3. Proximity switch open.	3. Replace.

<b>Problem</b>	<b>Possible Cause</b>	<b>Remedy</b>	
[1] The icemaker will not start. (Fill Cycle) (continued)	k) High Pressure Switch	1. Bad contacts.	1. Check for continuity and replace.
		2. Dirty air filter or condenser.	2. Clean.
		3. Ambient temperature too warm.	3. Reduce temperature.
		4. Refrigerant overcharged.	4. Recover, evacuate, and recharge.
		5. Fan not operating.	5. See "3.[2]a) Fan Motor."
		6. Refrigerant line or components restricted.	6. Remove the restriction or component and replace the drier.
	l) Plug and Receptacle (Control Box)	1. Disconnected.	1. Connect.
		2. Loose terminal.	2. Repair terminal connection.
	m) Control Board	1. Defective.	1. See "II.D.4. Control Board Check Procedure."
[2] Fill cycle will not terminate.	a) Water Supply	1. Water supply off or pressure too low.	1. Check and get recommended pressure.
	b) Float Switch	1. Connector disconnected.	1. Reconnect.
		2. Float does not move freely.	2. Clean or replace.
		3. Defective switch.	3. Check and replace.
	c) Water Control Relay	1. Contacts sticking.	1. Replace.
		2. Coil winding open.	2. Replace.
	d) Drain Valve	1. Valve seat won't seal and water leaking.	1. Clean or replace.
	e) Hoses	1. Disconnected or damaged.	1. Reconnect or replace.
f) Control Board	1. Defective.	1. See "II.D.4. Control Board Check Procedure."	

<b>Problem</b>	<b>Possible Cause</b>	<b>Remedy</b>		
[3] Ice purge cycle will not start.	a) Water Control Relay	1. Low water safety circuit open (bad contacts ).	1. Replace.	
	b) Ice Making Switch	1. Bad contacts.	1. Check for continuity and replace.	
	c) Bin Control	1. Open.	1. Bin full, check for continuity on proximity switch.	
	d) Control Board	1. Fails to operate gear motor relay.	1. See "II.D.4. Control Board Check Procedure."	
	e) Gear Motor Fuse	1. Blown.	1. Check gear motor amperage, bearing wear (see "V.D.1. Upper Bearing Wear Check"), and supply voltage.	
	f) Gear Motor Thermal Protector	1. Open.	1. Check gear motor bearings, supply voltage.	
	g) Gear Motor	1. Open windings.	1. Replace.	
		2. Auger coupling broke.	2. Replace.	
		3. Locked bearings.	3. Replace.	
[4] Freeze cycle will not start (compressor).	a) Gear Motor Protect Relay	1. Open coil.	1. Replace.	
		2. Open contacts.	2. Replace.	
	b) Control Board	1. Defective.	1. See "II.D.4. Control Board Check Procedure."	
		c) Starter (Start Relay)	1. Bad contacts.	1. Check for continuity and replace.
			2. Coil winding open.	2. Replace.
	3. Loose connections.	3. Tighten.		
	d) Start Capacitor or Run Capacitor	1. Defective.	1. Replace.	
	e) Compressor	1. Power supply not within specifications.	1. Refer to nameplate and correct.	
		2. Wiring to compressor.	2. Check for loose or open connection, repair or replace.	
		3. Defective.	3. Replace.	
4. Compressor locked and internal motor protector tripped.		4. Replace.		
[5] All components run, but no ice is produced.	a) Refrigerant	1. Low charge.	1. See "V.A. Service for Refrigerant Lines."	
		2. Refrigerant line or component restricted.	2. Remove the restriction or component and replace the drier.	
		3. Air or moisture trapped.	3. Recover refrigerant, replace drier, evacuate, and recharge.	

Problem	Possible Cause		Remedy
[5] All components run, but no ice is produced. (continued)	b) Expansion Valve	1. Bulb loose.	1. Secure bulb.
		2. Operating erratically.	2. Check and replace.
	c) Compressor	1. Defective.	1. Replace.
	d) Evaporator	1. Defective.	1. Replace.

## 2. Low Ice Production

Problem	Possible Cause		Remedy
[1] Low ice production.	a) Evaporator	1. Dirty or defective.	1. Clean or replace.
	b) Bin Control	1. Erratic, sticking, defective.	1. Clean or replace.
	c) Drain Valve	1. Leaking water.	1. Clean or replace.
	d) Expansion Valve	1. Bulb loose.	1. Secure bulb.
		2. Operating erratically.	2. Check and replace.
	e) Refrigerant Charge	1. Low charge.	1. See "V.A. Service for Refrigerant Lines."
		2. Overcharge.	2. See "V.A. Service for Refrigerant Lines."
	f) Refrigerant Line	1. Refrigerant line or component restricted.	1. Repair/replace the clogged line/component and replace the drier.
	g) High-Side Pressure Too High	1. Dirty air filter or condenser.	1. Clean.
		2. Ambient temperature too warm.	2. Reduce temperature.
		3. Fan motor slow rpm.	3. See "3.[2]a) Fan Motor."
		4. Fan motor capacitor.	4. Check and replace.
	h) Compressor	1. Inefficient compressor.	1. Replace
2. Faulty thermal protector (overload).		2. Replace compressor.	
3. Faulty capacitor/ starter.		3. Replace.	

### 3. Other

Problem	Possible Cause	Remedy	
[1] Icemaker will not stop when bin is filled with ice.	a) Bin Control	1. Actuator sticking.	1. Adjust or replace.
		2. Proximity switch closed.	2. Replace.
[2] Abnormal noise.	a) Fan Motor	1. Bearing worn out.	1. Replace.
		2. Fan blade deformed.	2. Replace fan blade.
		3. Fan blade does not move freely.	3. Replace.
	b) Compressor	1. Bearings worn out, or cylinder valve broken.	1. Replace.
		2. Mounting pad out of position.	2. Reinstall.
	c) Refrigerant Lines	1. Rub or touch other lines or surfaces.	1. Reposition.
	d) Auger	1. Bearings or auger worn out.	1. Replace bearings or auger. See "V.D. Removal and Replacement of Evaporator Assembly Components."
	e) Gear Motor	1. Bearing or gear worn out/damaged.	1. Replace.
	f) Evaporator	1. Scale on inside wall of evaporator freezing cylinder.	1. Use "SCALE AWAY" solution to clean periodically. See "VI.A. Cleaning and Sanitizing Instructions." If the water is found hard by testing, install a softener.
		2. Evaporator defective.	2. Replace.
[3] Overflow from reservoir (water does not stop).	a) Water Supply	1. Water pressure too high.	1. Install a pressure reducing valve.
	b) Inlet Water Valve	1. Diaphragm does not close.	1. Clean or replace.
	c) Float Switch	1. Bad contacts.	1. Check for continuity and replace.
	d) Water Control Relay	1. Bad contacts.	1. Replace
[4] Gear motor overload protector operates frequently or fuse blows frequently.	a) Power Supply	1. Not within specifications.	1. Refer to nameplate and correct.
	b) Evaporator Assembly	1. Bearings or auger worn out.	1. Replace bearings or auger. See "V.D.1. Upper Bearing Wear Check."
	c) Bin Control	1. Bad contacts.	1. Check for continuity and replace.
		2. Actuator does not move freely.	2. Clean actuator or replace bin control assembly.
d) Control Board	1. Erratic operation of gear motor relay.	1. See "II.D.4. Control Board Check Procedure."	



## 4. Dispensing

Problem	Possible Cause	Remedy	
[1] No ice dispensed.	a) Power Supply	1. Unplugged, off, blown fuse, or tripped breaker.	1. Plug in, turn on, replace, or reset.
		2. Loose connection.	2. Tighten.
		3. Bad contacts.	3. Check for continuity and replace.
		4. Not within specifications.	4. Refer to nameplate and correct.
	b) Power Switch (Control Box)	1. "OFF" position.	1. Move to "ON" position.
		2. Bad contacts.	2. Check for continuity and replace.
	c) Ice Storage	1. No ice or little ice in storage bin.	1. Make ice.
		2. Ice bridge or ice block formed.	2. Melt ice, resupply with new ice.
		3. Agitating motor defective.	3. Check, replace.
	d) Ice Dispense Switch	1. Bad contacts. (push button only)	1. Check for continuity and replace.
	e) Shutter Assembly	1. Broken part.	1. Check and replace.
		2. Open windings on solenoid.	2. Check continuity and replace.
	f) Dispense Gear Motor	1. Thermal protector is tripped.	1. Allow to cool.
		2. Gear motor winding open.	2. Replace.
		3. Bearing worn out.	3. Replace.
		4. Wiring to gear motor.	4. Check for loose connection or open circuit, and replace wiring as needed.
5. Defective capacitor.		5. Replace.	
g) Auger Mechanism	1. Bad alignment of auger.	1. Realign.	
h) Control Board	1. Defective.	1. See "II.D.4. Control Board Check Procedure."	
[2] Abnormal noise.	a) Gear Motor or Gear Head	1. Bearing worn out.	1. Replace.
	b) Auger Mechanism	1. Bad alignment of auger.	1. Realign.
		2. Foreign matter interrupting agitator.	2. Remove foreign matter.
c) Dispense Water Solenoid	1. Vibration due to loosening screws.	1. Apply thread sealant to the parts and tighten.	

<b>Problem</b>	<b>Possible Cause</b>		<b>Remedy</b>
[3] No water dispensed.	a) Power Supply	1. Unplugged, off, blown fuse, or tripped breaker.	1. Plug in, turn on, replace, or reset.
		2. Loose connection.	2. Tighten.
		3. Bad contacts.	3. Check for continuity and replace.
		4. Not within specifications.	4. Refer to nameplate and correct.
	b) Power Switch (Control Box)	1. "OFF" position.	1. Move to "ON" position.
		2. Bad contacts.	2. Check for continuity and replace.
	c) Water Supply	1. Water supply off or pressure too low.	1. Check and get recommended pressure.
	d) Dispensing Water Valve	1. Coil winding open.	1. Replace.
		2. Wiring to dispensing water valve.	2. Check for loose or open connection. Repair or replace.
	e) Control Board	1. Defective.	1. See "II.D.4. Control Board Check Procedure."
	f) Water Dispense Switch	1. Bad contacts. (push button only)	1. Check for continuity and replace.

---

## V. Removal and Replacement of Components

### IMPORTANT

1. Ensure all components, fasteners, and thumbscrews are securely in place after the equipment is serviced.
2. The Polyol Ester (POE) oils used in R-404A units can absorb moisture quickly. Therefore it is important to prevent moisture from entering the system when replacing or servicing parts.
3. Always install a new drier every time the sealed refrigeration system is opened. Do not replace the drier until after all other repair or replacement has been made.
4. Do not leave the system open for longer than 15 minutes when replacing or servicing parts.

### A. Service for Refrigerant Lines

#### WARNING

Use an electronic leak detector or soap bubbles to check for leaks. Add a trace of refrigerant to the system (if using an electronic leak detector), and then raise the pressure using nitrogen gas (140 PSIG). DO NOT use R-404A as a mixture with pressurized air for leak testing.

#### 1. Refrigerant Recovery

The icemaker is provided with refrigerant access valves. Using proper refrigerant practices, recover the refrigerant from the access valves and store it in an approved container. Do not discharge the refrigerant into the atmosphere.

#### 2. Brazing

#### WARNING

1. R-404A itself is not flammable at atmospheric pressure and temperatures up to 176°F (80°C).
2. R-404A itself is not explosive or poisonous. However, when exposed to high temperatures (open flames), R-404A can be decomposed to form hydrofluoric acid and carbonyl fluoride both of which are hazardous.
3. Always recover the refrigerant and store it in an approved container. Do not discharge the refrigerant into the atmosphere.
4. Do not use silver alloy or copper alloy containing arsenic.
5. Use an electronic leak detector or soap bubbles to check for leaks. Add a trace of refrigerant to the system (if using an electronic leak detector), and then raise the pressure using nitrogen gas (140 PSIG). DO NOT use R-404A as a mixture with pressurized air for leak testing.

- 1) Always install a new drier every time the sealed refrigeration system is opened. Do not replace the drier until after all other repair or replacement has been made. Install the new drier with the arrow on the drier in the direction of the refrigerant flow.
- 2) Braze all fittings while purging with nitrogen gas flowing at a pressure of 3 to 4 PSIG.
- 3) Use an electronic leak detector or soap bubbles to check for leaks. Add a trace of refrigerant to the system (if using an electronic leak detector), and then raise the pressure using nitrogen gas (140 PSIG). DO NOT use R-404A as a mixture with pressurized air for leak testing.

### **3. Evacuation and Recharge (R-404A)**

- 1) Attach a vacuum pump to the system. Be sure to connect the charging hoses to both high and low-side access valves.

#### **IMPORTANT**

The vacuum level and vacuum pump may be the same as those for current refrigerants. However, the rubber hose and gauge manifold to be used for evacuation and refrigerant charge should be exclusively for POE oils.

- 2) Turn on the vacuum pump. Open the service manifold valves. Never allow the oil in the vacuum pump to flow backwards.
- 3) Allow the vacuum pump to pull down to a 29.9" Hg vacuum. Evacuating period depends on pump capacity.
- 4) Close the low-side valve and high-side valve on the service manifold.
- 5) Disconnect the vacuum pump and attach a refrigerant service cylinder to the high-side line. Remember to loosen the connection and purge the air from the hose. See the nameplate for the required refrigerant charge. Hoshizaki recommends only virgin refrigerant or reclaimed refrigerant which meets ARI Standard No. 700-88 be used.
- 6) A liquid charge is recommended for charging an R-404A system. Invert the service cylinder and place it on scales. Open the high-side valve on the service manifold.
- 7) Allow the system to charge with liquid until the proper charge weight is met.
- 8) If necessary, add any remaining charge to the system through the low-side. Use a throttling valve or liquid dispensing device to add the remaining liquid charge through the low-side access port with the unit running.
- 9) Close the service manifold valves and disconnect the service manifold hoses.
- 10) Cap the access valves to prevent a possible leak.

## B. Removal and Replacement of Compressor

### IMPORTANT

Always install a new drier every time the sealed refrigeration system is opened. Do not replace the drier until after all other repair or replacement has been made.

Note: When replacing a compressor with a defective winding, be sure to install the new start capacitor and start relay supplied with the replacement compressor. Due to the ability of the POE oil in the compressor to absorb moisture quickly, the compressor must not be opened more than 15 minutes for replacement or service. Do not mix lubricants of different compressors even if both are charged with R-404A, except when they use the same lubricant.

- 1) Move the ice making switch to the "OFF" position, then turn off the power supply. Remove the front and top panels, then move the power switch to the "OFF" position. Remove the plug from the mains socket.
- 2) Remove the apron panel, then remove the right side panel.
- 3) Disconnect the drip tray hose from the tee. Remove the four screws securing the drip tray, then remove the drip tray and hose.
- 4) Recover the refrigerant and store it in an approved container.
- 5) Remove the terminal cover on the compressor and disconnect the compressor wiring.
- 6) Remove the discharge, suction, and process pipes.
- 7) Remove the compressor hold-down bolts, washers, and rubber grommets.
- 8) Remove the compressor. Unpack the new compressor package.
- 9) Attach the rubber grommets of the prior compressor to the new compressor.
- 10) Place the compressor in position and secure it using the bolts and washers.
- 11) Remove the drier, then place the new drier in position.
- 12) Remove plugs from the suction, discharge, and process pipes.
- 13) Braze all fittings while purging with nitrogen gas flowing at a pressure of 3 to 4 PSIG.
- 14) Use an electronic leak detector or soap bubbles to check for leaks. Add a trace of refrigerant to the system (if using an electronic leak detector), and then raise the pressure using nitrogen gas (140 PSIG). DO NOT use R-404A as a mixture with pressurized air for leak testing.
- 15) Evacuate the system, and charge it with refrigerant. See the nameplate for the required refrigerant charge.
- 16) Connect the terminals and replace the terminal cover in its correct position.
- 17) Replace the drip tray and drip tray hose in their correct positions. Secure the hose to the tee. Pour water into the drip tray and check for leaks.
- 18) Move the power switch to the "ON" position, then replace the panels in their correct positions.
- 19) Plug the unit back in, then turn on the power supply. Move the ice making switch to the "ICE" position to start the automatic icemaking process.

## C. Removal and Replacement of Expansion Valve

### IMPORTANT

Sometimes moisture in the refrigeration circuit exceeds the drier capacity and freezes up at the expansion valve. Always install a new drier every time the sealed refrigeration system is opened. Do not replace the drier until after all other repair or replacement has been made.

- 1) Move the ice making switch to the "OFF" position, then turn off the power supply. Remove the front and top panels, then move the power switch to the "OFF" position. Remove the plug from the mains socket.
- 2) Remove the apron panel, then remove the left side panel.
- 3) Recover the refrigerant and store it in an approved container.
- 4) Disconnect the drip tray hose from the tee. Remove the four screws securing the drip tray, then remove the drip tray and hose.
- 5) Remove the insulation and the expansion valve bulb on the suction line.
- 6) Remove the expansion valve cover and disconnect the expansion valve.
- 7) Place the new expansion valve in position.
- 8) Remove the drier, then place the new drier in position.
- 9) Braze all fittings while purging with nitrogen gas flowing at a pressure of 3 to 4 PSIG.

### CAUTION

Always protect the valve body by using a damp cloth to prevent the valve from overheating. Do not braze with the valve body exceeding 250°F (121°C).

- 10) Use an electronic leak detector or soap bubbles to check for leaks. Add a trace of refrigerant to the system (if using an electronic leak detector), and then raise the pressure using nitrogen gas (140 PSIG). DO NOT use R-404A as a mixture with pressurized air for leak testing.
- 11) Evacuate the system, and charge it with refrigerant. See the nameplate for the required refrigerant charge.
- 12) Attach the expansion valve bulb to the suction line in the same location as the previous bulb. The bulb should be at the 12 o'clock position on the tube. Be sure to secure the bulb with the clamp and holder and to insulate it.
- 13) Place the expansion valve cover in position.
- 14) Replace the drip tray and drip tray hose in their correct positions. Secure the hose to the tee. Pour water into the drip tray and check for leaks.
- 15) Move the power switch to the "ON" position, then replace the panels in their correct positions.
- 16) Plug the unit back in, then turn on the power supply. Move the ice making switch to the "ICE" position to start the automatic icemaking process.

## D. Removal and Replacement of Evaporator Assembly Components

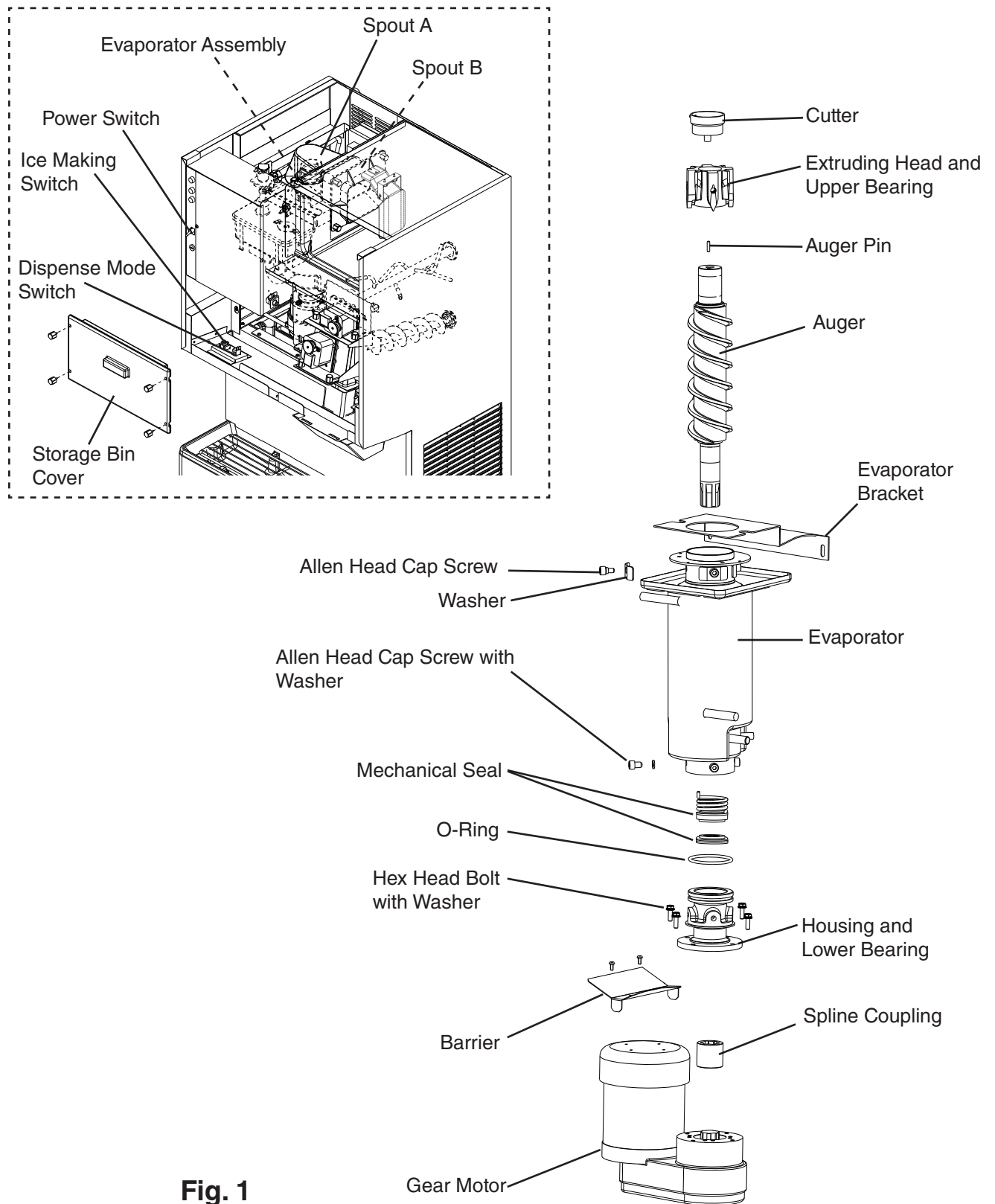
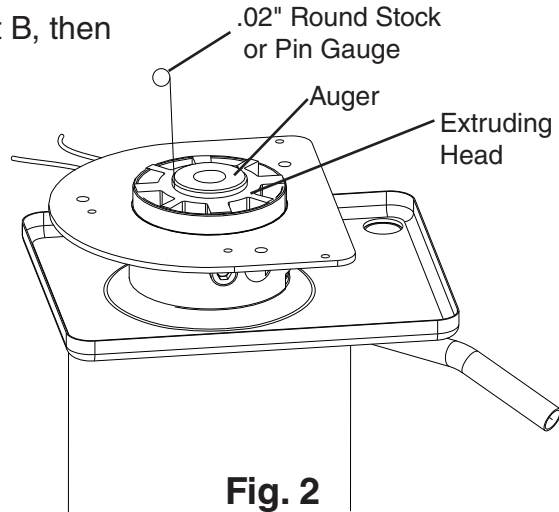

**Fig. 1**

## 1. Upper Bearing Wear Check

To ensure that the bearing inside the extruding head does not exceed the wear tolerance of .02", follow the instructions below. See Fig. 2.

- 1) Move the ice making switch to the "OFF" position, then turn off the power supply. Remove the front and top panels, then move the power switch to the "OFF" position. Remove the plug from the mains socket.
- 2) Remove the storage bin cover. Remove spout B, then remove spout A and the cutter. See Fig. 1.
- 3) Grasp the top of the auger and move the auger towards you and then try to insert a .02" round stock or pin gauge in between the back side of the auger shaft and the bearing surface. Check several locations around the auger shaft. If the gauge goes between the shaft and the bearing at any point or if the bearing is scratched or cracked, both the top bearing in the extruding head and the lower bearing in the housing should be replaced. Instructions for removing the extruding head and housing are located later in this procedure.



**Fig. 2**

Note: Replacing the bearing requires a bearing press adaptor. If one is not available, replace the whole extruding head and housing.

- 4) Replace the cutter, spout A, spout B, and the storage bin cover in their correct positions.
- 5) Move the power switch to the "ON" position, then replace the panels in their correct positions.
- 6) Plug the unit back in, then turn on the power supply. Move the ice making switch to the "ICE" position to start the automatic icemaking process.

## 2. Removal and Replacement of Extruding Head

- 1) Move the ice making switch to the "OFF" position, then turn off the power supply. Remove the front and top panels, then move the power switch to the "OFF" position. Remove the plug from the mains socket.
- 2) Open the drain valve to drain all of the water from the evaporator. Close the drain valve.
- 3) Remove the storage bin cover. Remove spout B, then remove spout A and the cutter. See Fig. 1.
- 4) Remove the apron panel, then remove the left side panel.
- 5) Remove the allen head cap screws and lift off the extruding head.
- 6) Place the new extruding head in place and tighten down the allen head cap screws.
- 7) Replace the cutter in its correct position.
- 8) Replace spout A, spout B, and the storage bin cover in their correct positions.



- 9) Move the power switch to the "ON" position, then replace the panels in their correct positions.
- 10) Plug the unit back in, then turn on the power supply. Move the ice making switch to the "ICE" position to start the automatic icemaking process.

### **3. Removal and Replacement of Auger**

- 1) Move the ice making switch to the "OFF" position, then turn off the power supply. Remove the front and top panels, then move the power switch to the "OFF" position. Remove the plug from the mains socket.
- 2) Open the drain valve to drain all of the water from the evaporator. Close the drain valve.
- 3) Remove the storage bin cover. Remove spout B, then remove spout A. See Fig. 1.
- 4) Remove the apron panel, then remove the left side panel.
- 5) Remove the allen head cap screws securing the extruding head. Using the cutter, lift out the auger assembly.
- 6) Remove the cutter, extruding head, and upper part of the mechanical seal from the auger and place them on the new auger.
- 7) Install the new auger assembly with the upper part of the mechanical seal attached and tighten down the allen head cap screws.
- 8) Replace spout A, spout B, and the storage bin cover in their correct positions.
- 9) Move the power switch to the "ON" position, then replace the panels in their correct positions.
- 10) Plug the unit back in, then turn on the power supply. Move the ice making switch to the "ICE" position to start the automatic icemaking process.

### **4. Removal and Replacement of Evaporator**

#### **IMPORTANT**

Always install a new drier every time the sealed refrigeration system is opened. Do not replace the drier until after all other repair or replacement has been made.

- 1) Move the ice making switch to the "OFF" position, then turn off the power supply. Remove the front and top panels, then move the power switch to the "OFF" position. Remove the plug from the mains socket.
- 2) Open the drain valve to drain all of the water from the evaporator. Close the drain valve.
- 3) Remove the apron panel, then remove the left side panel.
- 4) Recover the refrigerant and store it in an approved container.
- 5) Disconnect the drip tray hose from the tee. Remove the four screws securing the drip tray, then remove the drip tray and hose.
- 6) Remove the storage bin cover. Remove spout B, then remove spout A. See Fig. 1.
- 7) Remove the allen head cap screws securing the extruding head. Using the cutter, lift out the auger assembly.

- 8) Remove the evaporator bracket and disconnect the water hoses.
- 9) Disconnect the inlet and outlet tubing.
- 10) Remove the allen head cap screws securing the evaporator to the lower housing.
- 11) Lift off the evaporator.
- 12) Inspect the mechanical seal and O-ring prior to installing the new evaporator. The mechanical seal consists of two parts. One moves along with the auger, and the other is fixed on the lower housing. If the contact surfaces of these two parts are worn, cracked, or scratched, the mechanical seal may cause water leaks and must be replaced. Instructions for removing the mechanical seal and lower housing are located later in this procedure.
- 13) Make sure the lower mechanical seal is in place, then place the new evaporator in position. Secure the evaporator to the lower housing using the allen head cap screws.
- 14) Remove the drier, then place the new drier in position.
- 15) Braze all fittings while purging with nitrogen gas flowing at a pressure of 3 to 4 PSIG.
- 16) Use an electronic leak detector or soap bubbles to check for leaks. Add a trace of refrigerant to the system (if using an electronic leak detector), and then raise the pressure using nitrogen gas (140 PSIG). DO NOT use R-404A as a mixture with pressurized air for leak testing.
- 17) Evacuate the system, and charge it with refrigerant. See the nameplate for the required refrigerant charge.
- 18) Install the auger assembly with the upper part of the mechanical seal attached and tighten down the allen head cap screws.
- 19) Replace the evaporator bracket and reconnect the water hoses.
- 20) Replace spout A, spout B, and the storage bin cover in their correct positions.
- 21) Replace the drip tray and drip tray hose in their correct positions. Secure the hose to the tee. Pour water into the drip tray and check for leaks.
- 22) Move the power switch to the "ON" position, then replace the panels in their correct positions.
- 23) Plug the unit back in, then turn on the power supply. Move the ice making switch to the "ICE" position to start the automatic icemaking process.

## **5. Removal and Replacement of Mechanical Seal and Lower Housing**

### **5a. Mechanical Seal**

- 1) Move the ice making switch to the "OFF" position, then turn off the power supply. Remove the front and top panels, then move the power switch to the "OFF" position. Remove the plug from the mains socket.
- 2) Open the drain valve to drain all of the water from the evaporator. Close the drain valve.
- 3) Remove the storage bin cover. Remove spout B, then remove spout A. See Fig. 1.
- 4) Remove the apron panel, then remove the left side panel.
- 5) Remove the allen head cap screws securing the extruding head.
- 6) Using the cutter, lift out the auger assembly, then remove the evaporator bracket.

- 7) The mechanical seal consists of two parts. One moves along with the auger, and the other is fixed on the lower housing. If the contact surfaces of these two parts are worn, cracked, or scratched, the mechanical seal may cause water leaks and must be replaced.
- 8) Remove the allen head cap screws securing the evaporator to the lower housing.
- 9) Raise the evaporator up to access the lower housing.
- 10) Remove the mechanical seal from the housing. If only replacing the mechanical seal, proceed to step 13.

### **CAUTION**

To help prevent water leaks, be careful not to damage the surfaces of the O-ring or mechanical seal.

## **5b. Lower Housing**

- 11) Remove the O-ring and the bolts securing the housing to the gear motor and remove the housing from the gear motor. If inspection of the upper bearing inside the extruding head (see "V.D.1. Upper Bearing Wear Check") indicates that it is out of tolerance, replace both it and the bearing inside the lower housing.  
Note: Replacing the bearing requires a bearing press adaptor. If one is not available, replace the whole extruding head and housing.
- 12) Install the O-ring and mount the lower housing on the gear motor.
- 13) Install the lower part of the mechanical seal on the lower housing.
- 14) Lower the evaporator down and secure it to the lower housing.
- 15) Install the auger assembly with the upper part of the mechanical seal attached.
- 16) Replace the evaporator bracket in its correct position.
- 17) Replace spout A, spout B, and the storage bin cover in their correct positions.
- 18) Move the power switch to the "ON" position, then replace the panels in their correct positions.
- 19) Plug the unit back in, then turn on the power supply. Move the ice making switch to the "ICE" position to start the automatic icemaking process.

## **6. Removal and Replacement of Gear Motor**

- 1) Move the ice making switch to the "OFF" position, then turn off the power supply. Remove the front and top panels, then move the power switch to the "OFF" position. Remove the plug from the mains socket.
- 2) Open the drain valve to drain all of the water from the evaporator. Close the drain valve.
- 3) Remove the storage bin cover. Remove spout B, then remove spout A. See Fig. 1.
- 4) Remove the apron panel, then remove the left side panel.
- 5) Remove the evaporator bracket.
- 6) Remove the bolts securing the lower housing to the gear motor. Lift the evaporator up slightly.

- 7) Remove the gear motor/drain pan bolts.  
See Fig. 3.
- 8) Disconnect the wiring from the gear motor, then remove the gear motor from the drain pan.
- 9) Remove the gear motor bracket from the old gear motor and attach to the new gear motor.
- 10) Remove the spline coupling and gear motor cover from the old gear motor and attach to the new gear motor. The narrow side of the gear motor cover should be towards the evaporator. After tightening the mounting screws, apply silicone caulk to the heads to seal them.
- 11) Place the new gear motor in the drain pan.
- 12) Using the gear motor/drain pan bolts and washers, secure the gear motor and drain pan to the drain pan bracket.
- 13) Connect the gear motor wires.
- 14) Lower the evaporator down and secure it to the gear motor.
- 15) Replace the evaporator bracket in its correct position.
- 16) Replace spout A, spout B, and the storage bin cover in their correct positions.
- 17) Move the power switch to the "ON" position, then replace the panels in their correct positions.
- 18) Plug the unit back in, then turn on the power supply. Move the ice making switch to the "ICE" position to start the automatic icemaking process.

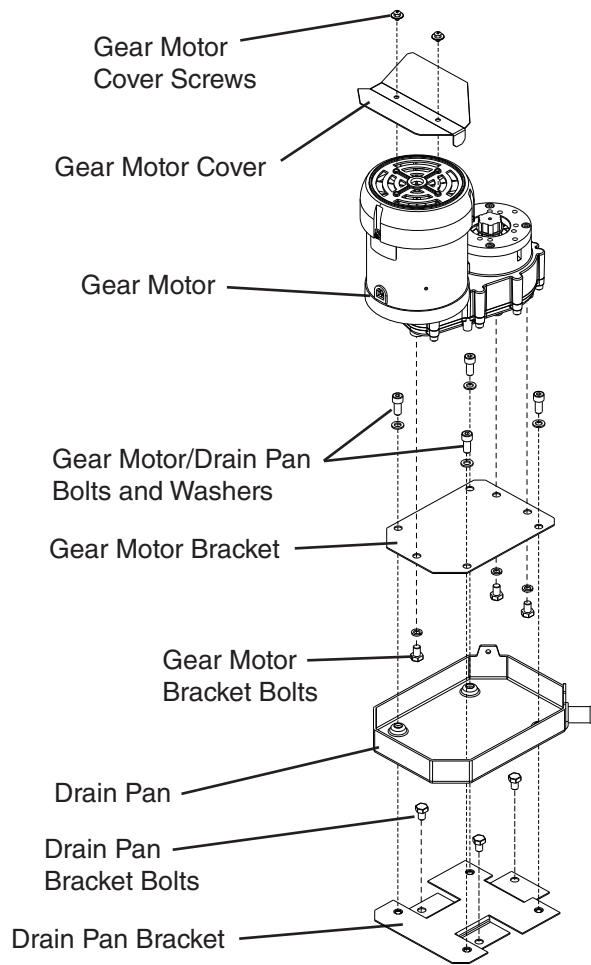

**Fig. 3**

## E. Removal and Replacement of Air-Cooled Condenser

### IMPORTANT

Always install a new drier every time the sealed refrigeration system is opened. Do not replace the drier until after all other repairs or replacement have been made.

- 1) Move the ice making switch to the "OFF" position, then turn off the power supply. Remove the front and top panels, then move the power switch to the "OFF" position. Remove the plug from the mains socket.
- 2) Remove the apron panel, then remove the left side panel.
- 3) Recover the refrigerant and store it in an approved container.
- 4) Disconnect the drip tray hose from the tee. Remove the four screws securing the drip tray, then remove the drip tray and hose.
- 5) Remove the four bolts securing the fan motor assembly to the floor of the machine, then move the assembly to the side.
- 6) Disconnect the condenser inlet and outlet piping.
- 7) Remove the screws securing the condenser assembly, then remove the assembly.
- 8) Remove the shroud from the old condenser and attach it to the new condenser.
- 9) Install the new condenser.
- 10) Remove the drier, then place the new drier in position.
- 11) Braze all fittings while purging with nitrogen gas flowing at a pressure of 3 to 4 PSIG.
- 12) Use an electronic leak detector or soap bubbles to check for leaks. Add a trace of refrigerant to the system (if using an electronic leak detector), and then raise the pressure using nitrogen gas (140 PSIG). DO NOT use R-404A as a mixture with pressurized air for leak testing.
- 13) Evacuate the system, and charge it with refrigerant. See the nameplate for the required refrigerant charge.
- 14) Replace the fan motor assembly in its correct position.
- 15) Replace the drip tray and drip tray hose in their correct positions. Secure the hose to the tee. Pour water into the drip tray and check for leaks.
- 16) Move the power switch to the "ON" position, then replace the panels in their correct positions.
- 17) Plug the unit back in, then turn on the power supply. Move the ice making switch to the "ICE" position to start the automatic icemaking process.

## F. Removal and Replacement of Fan Motor

- 1) Move the ice making switch to the "OFF" position, then turn off the power supply. Remove the front and top panels, then move the power switch to the "OFF" position. Remove the plug from the mains socket.
- 2) Remove the apron panel.

- 3) Disconnect the wire connectors from the fan motor leads.
- 4) Remove the fan motor bracket.
- 5) Remove the fan blade and install it onto the new fan motor.
- 6) Install the new fan motor onto the fan motor bracket.
- 7) Replace the fan motor bracket in its correct position and reconnect the wire connectors.
- 8) Move the power switch to the "ON" position, then replace the panels in their correct positions.
- 9) Plug the unit back in, then turn on the power supply. Move the ice making switch to the "ICE" position to start the automatic icemaking process.

## **G. Removal and Replacement of Inlet or Dispensing Water Valve**

- 1) Close the water supply line shut-off valve.
- 2) Open the water supply line drain valve.
- 3) Move the ice making switch to the "OFF" position, then turn off the power supply. Remove the front and top panels, then move the power switch to the "OFF" position. Remove the plug from the mains socket.
- 4) Remove the apron panel. For the inlet water valve, remove the left side panel. For the dispensing water valve, remove the right side panel.
- 5) Disconnect the wire terminals from the water valve.
- 6) Loosen the fitting nut on the water valve. Do not lose the washer inside the fitting nut.
- 7) Remove the water valve bracket (inlet water valve) or water valve (dispensing water valve).
- 8) Remove the old water valve and install the new water valve. Remove the supply hose from the old water valve and place on the new water valve.
- 9) Replace the water valve bracket (inlet water valve) or water valve (dispensing water valve) in its correct position.
- 10) Reconnect the wire terminals.
- 11) Reconnect the fitting nut on the water valve. Make sure the washer is in place in the fitting nut.
- 12) Close the water supply line drain valve and open the water supply line shut-off valve.
- 13) Check for water leaks.
- 14) Move the power switch to the "ON" position, then replace the panels in their correct positions.
- 15) Plug the unit back in, then turn on the power supply. Move the ice making switch to the "ICE" position to start the automatic icemaking process.

## **H. Removal and Replacement of Drain Valve**

- 1) Close the water supply line shut-off valve.
- 2) Move the ice making switch to the "OFF" position, then turn off the power supply. Remove the front and top panels, then move the power switch to the "OFF" position. Remove the plug from the mains socket.
- 3) Prepare a container to catch water from the reservoir and evaporator, then disconnect the hose from the drain valve and allow all of the water from the reservoir and evaporator to drain into the container.
- 4) Remove the old drain valve and install the new drain valve.
- 5) Reconnect the hoses.
- 6) Open the water supply line shut-off valve.
- 7) Plug the unit back in, then turn on the power supply. Move the power switch to the "ON" position, then move the ice making switch to the "ICE" position.
- 8) Allow the icemaker to fill for two minutes.
- 9) Move the ice making switch to the "OFF" position.
- 10) Check for water leaks.
- 11) Open the drain valve. Make sure that water is draining and that there are no water leaks around the hose connection.
- 12) Move the ice making switch to the "OFF" position.
- 13) Replace the panels in their correct positions.
- 14) Move the ice making switch to the "ICE" position to start the automatic ice making process.

## **I. Removal and Replacement of Dispensing System**

### **1. Dispensing Auger and Agitator**

- 1) Move the ice making switch to the "OFF" position, then turn off the power supply. Remove the front and top panels, then move the power switch to the "OFF" position. Remove the plug from the mains socket.
- 2) Remove the storage bin cover.
- 3) Remove the thumbscrews from the vertical plane, then loosen the thumbscrews from the horizontal plane of the motor bracket. Slide the motor back.  
Note: Hold the dispensing auger/agitator to prevent it from dropping when sliding back the motor. See Fig. 4.
- 4) Replace the dispensing auger/agitator with the new one.
- 5) Assemble the removed parts in the reverse order of which they were removed.
- 6) Move the power switch to the "ON" position, then replace the panels in their correct positions.
- 7) Plug the unit back in, then turn on the power supply. Move the ice making switch to the "ICE" position to start the automatic icemaking process.

## 2. Dispensing or Agitating Motor

- 1) Move the ice making switch to the "OFF" position, then turn off the power supply.  
Remove the front and top panels, then move the power switch to the "OFF" position.  
Remove the plug from the mains socket.
- 2) Remove the storage bin front panel.
- 3) Remove the thumbscrews from the vertical plane, then loosen the thumbscrews from the horizontal plane of the motor bracket. Slide the motor back.  
Note: Hold the dispensing auger/agitator to prevent it from dropping when sliding back the motor. See Fig. 4.
- 4) Remove the thumbscrews from the horizontal plane of the motor bracket.
- 5) Remove the motor from the bracket.
- 6) Install the new motor.
- 7) Assemble the removed parts in the reverse order of which they were removed.
- 8) Move the power switch to the "ON" position, then replace the panels in their correct positions.
- 9) Plug the unit back in, then turn on the power supply. Move the ice making switch to the "ICE" position to start the automatic icemaking process.

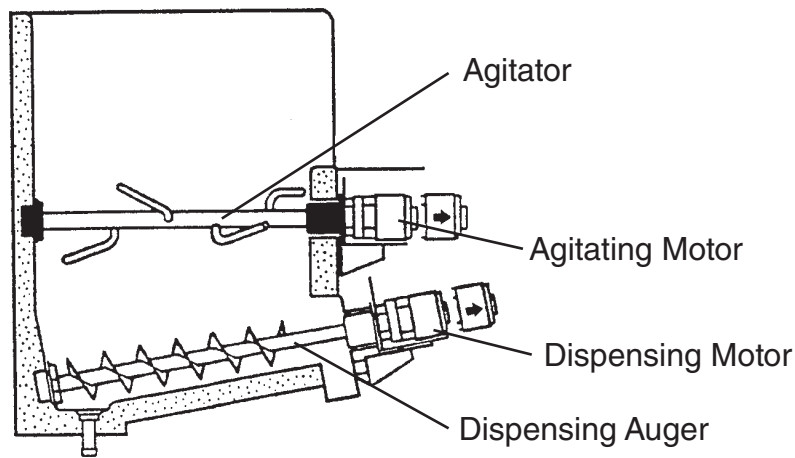

**Fig. 4**



## VI. Cleaning and Maintenance

### IMPORTANT

Ensure all components, fasteners, and thumbscrews are securely in place after any cleaning or maintenance is done to the equipment.

### A. Cleaning and Sanitizing Instructions

Hoshizaki recommends cleaning this unit at least twice a year. More frequent cleaning, however, may be required in some existing water conditions.

### WARNING

1. To prevent injury to individuals, do not use any ammonia type cleaners.
2. Carefully follow any instructions provided with the bottles of cleaning and sanitizing solution.
3. Always wear liquid-proof gloves to prevent the cleaning and sanitizing solutions from coming into contact with skin.
4. After cleaning, do not use ice made from the cleaning and sanitizing solutions. Be careful not to leave any solution on the parts or in the storage bin.

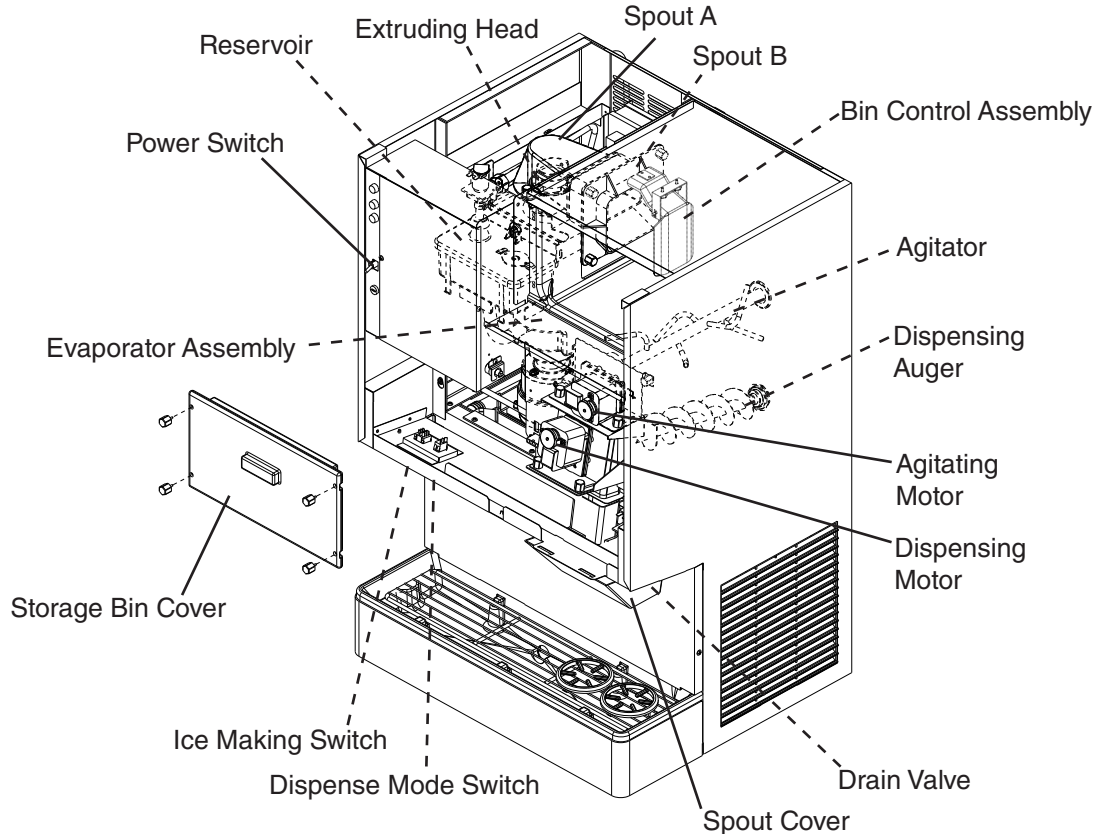

**Fig. 5**

## 1. Water System

### a) *Cleaning Solution*

Dilute 9.6 fl. oz. (0.29 l) of Hoshizaki "Scale Away" with 1.6 gal. (6.0 l) of warm water. This is a minimum amount. Make more solution if necessary.

### b) *Cleaning Procedure*

1. Move the ice making switch to the "OFF" position. See Fig. 5.
2. Close the water supply line shut-off valve.
3. Move the dispense mode switch to the "CONTINUOUS" position, then dispense all of the ice from the storage bin.
4. Open the drain valve and allow the water system to drain. Close the drain valve after the water system has drained.
5. Make sure at least 2.5 minutes have elapsed since moving the ice making switch to the "OFF" position. This allows the components to cycle down. Remove the plug from the mains socket. Remove the front and top panels, then move the power switch to the "OFF" position.
6. Remove the storage bin cover. Remove spout B, then remove spout A.
7. Pour the cleaning solution over the extruding head until the evaporator assembly and the reservoir are full and the solution starts to overflow into the drain pan.  
Note: If there is excess scale on the extruding head, fill the evaporator assembly and reservoir as described above, then use a clamp on the reservoir hose between the reservoir and evaporator assembly to block flow. Pour additional cleaning fluid over the extruding head until the evaporator assembly is completely full.
8. Replace spout A, spout B, and the storage bin cover in their correct positions.
9. Allow the icemaker to sit for about 10 minutes before operation. If you placed a clamp on the reservoir hose in step 7, remove it before operation.
10. Move the power switch to the "ON" position and replace the panels in their correct positions. Plug the unit back in, then move the ice making switch to the "ON" position. Make ice using the solution until the icemaker stops making ice.
11. Open the drain valve and allow the water system to drain. Close the valve after the water system has drained.
12. Open the water supply line shut-off valve to supply water to the reservoir.
13. After the gear motor starts, close the water supply line shut-off valve. Open the drain valve and allow the water system to drain. Close the drain valve after the water system has drained.  
Note: If you do not sanitize the unit, open the water supply line shut-off valve after the water system drains. Allow the icemaker to run for about 30 minutes, then move the ice making switch to the "OFF" position. Wait at least 2.5 minutes to allow the components to cycle down, then remove the plug from the mains socket. Remove the front panel, then move the power switch to the "OFF" position. Remove the storage bin cover. Go to step 12 in "Cleaning & Sanitizing Procedure" under "Dispensing Components."

14. Move the ice making switch to the "OFF" position. Wait at least 2.5 minutes to allow the components to cycle down, then remove the plug from the mains socket.

**c) Sanitizing Solution**

Dilute 0.82 fl. oz. (25 ml) of a 5.25% sodium hypochlorite solution (chlorine bleach) with 1.6 gal. (6.0 l) of warm water. This is a minimum amount. Make more solution if necessary.

**d) Sanitizing Procedure - Following Cleaning Procedure**

1. Make sure the ice making switch is in the "OFF" position, the unit is unplugged, and the water supply line shut-off valve is closed.
2. Remove the front and top panels, then move the power switch to the "OFF" position.
3. Remove the storage bin cover. Remove spout B, then remove spout A.
4. Pour the sanitizing solution over the extruding head until the evaporator assembly and the reservoir are full and the solution starts to overflow into the drain pan.
5. Replace spout A, spout B, and the storage bin cover in their correct positions.
6. Allow the icemaker to sit for about 10 minutes before operation.
7. Move the power switch to the "ON" position and replace the panels in their correct positions. Plug the unit back in, then move the ice making switch to the "ON" position. Make ice using the solution until the icemaker stops making ice.
8. Open the drain valve and allow the water system to drain. Close the valve after the water system has drained.
9. Open the water supply line shut-off valve to supply water to the reservoir.
10. After the gear motor starts, close the water supply line shut-off valve. Open the drain valve and allow the water system to drain. Close the drain valve after the water system has drained.
11. Open the water supply line shut-off valve after the water system drains. Allow the icemaker to run for about 30 minutes, then clean and sanitize the dispensing components as outlined below.

**2. Dispensing Components**

Perform after cleaning and sanitizing the water system as outlined above.

**a) Cleaning Solution**

Dilute 9.6 fl. oz. (0.29 l) of Hoshizaki "Scale Away" with 1.6 gal. (6.0 l) of warm water. This is a minimum amount. Make more solution if necessary.

**b) Sanitizing Solution**

Dilute 0.82 fl. oz. (25 ml) of a 5.25% sodium hypochlorite solution (chlorine bleach) with 1.6 gal. (6.0 l) of warm water. This is a minimum amount. Make more solution if necessary.

**c) Cleaning & Sanitizing Procedure**

1. Move the ice making switch to the "OFF" position. Wait at least 2.5 minutes to allow the components to cycle down, then remove the plug from the mains socket.
2. Remove the front and top panels, then move the power switch to the "OFF" position.
3. Remove the storage bin cover.
4. Remove the motor bracket thumbscrews from the vertical plane, then loosen the motor bracket thumbscrews on the horizontal plane. While holding on to the corresponding agitator or auger, move the agitating motor or the dispensing motor towards you. Remove the agitator and the dispensing auger from the storage bin. See Fig. 5.
5. Remove the bin control assembly.
6. Remove the snap pin, shaft, and actuator. See Fig. 6.
7. Remove spout B, spout A, and their gaskets.
8. Remove the spout cover, ice dispensing spout, and water dispensing nozzle. See Fig. 7.
9. Immerse the agitator, dispensing auger, and parts removed in steps 5 through 8 in the cleaning solution and then in the sanitizing solution for about 15 minutes each. Rinse the parts thoroughly with clean water.
10. Wipe the shutter located above the ice dispensing spout thoroughly with a clean cloth.
11. Reassemble the bin control assembly and replace all parts in the reverse order of which they were removed.
12. Pour warm water into the storage bin and melt any remaining ice. Clean the storage bin liner and the storage bin cover using a neutral cleaner. Rinse thoroughly after cleaning. Replace the storage bin cover in its correct position.
13. Move the power switch to the "ON" position and replace the panels in their correct positions. Plug the unit back in, then move the ice making switch to the "ON" position to start the automatic icemaking process.

## B. Maintenance

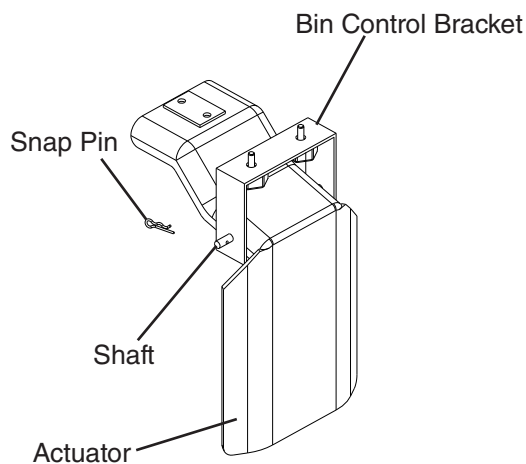

**Fig. 6**

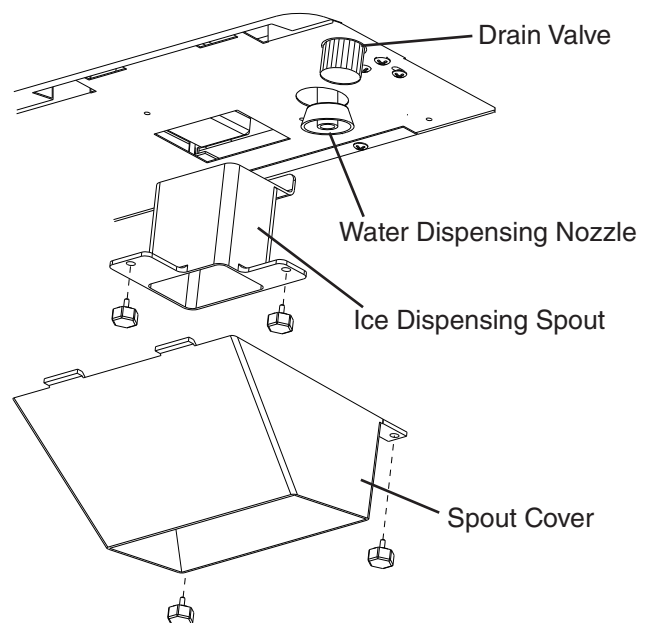

**Fig. 7**

This icemaker must be maintained individually, referring to the instruction manual and labels provided with the icemaker. The schedule below is a guideline. More frequent maintenance, however, may be required depending on water quality, the icemaker's environment, and local sanitation regulations. Consult with your local distributor about inspection and maintenance service.

### WARNING

1. Only qualified service technicians should attempt to service or maintain this icemaker.
2. Disconnect power before performing maintenance.

<b>Maintenance Schedule</b>		
<b>Frequency</b>	<b>Area</b>	<b>Task</b>
Every 2 Weeks	Air Filter	Inspect. Wash with warm water and neutral cleaner if dirty.
Monthly	External Water Filters	Check for proper pressure and change if necessary.
	Icemaker Exterior	Wipe down with a clean, soft cloth. Use a damp cloth containing a neutral cleaner to wipe off oil or dirt build up. Clean any chlorine staining (rust colored spots) using a non-abrasive cleaner like Zud or Bon Ami.
Every 6 Months	Icemaker and Storage Bin	Clean and sanitize per the cleaning and sanitizing instructions provided on this label.
	Evaporator Condensate Drain Pan and Gear Motor Drain Pan	Wipe down with a clean cloth and warm water. Slowly pour one cup of sanitizing solution (prepare as outlined in the sanitizing instructions on this label) into the evaporator condensate drain pan. Be careful not to overflow the pan. This solution will flow down to the gear motor drain pan and out the drain line to sanitize these areas. Repeat with a cup of clean water to rinse.
	Icemaker and Bin Drains	Check to make sure they are clear.
Yearly	Inlet Water Valve and Drain Valve	Close the water supply line shut-off valve and drain the water system. Clean the inlet water valve screen and clean and inspect the drain valve.
	Water Hoses	Inspect the water hoses and clean/replace if necessary.
	Condenser	Inspect. Clean if necessary by using a brush or vacuum cleaner.
	Icemaker	Inspect for oil spots, loose components, fasteners, and wires.
	Upper Bearing (extruding head)	Check for wear using .02" round stock or pin gauge. Replace both upper bearing and lower bearing if wear exceeds factory recommendations. See "V.D.1. Upper Bearing Wear Check" for details.
After 3 Years, then Yearly	Upper Bearing (extruding head); Lower Bearing and O-Ring (lower housing); Mechanical Seal; Evaporator Cylinder; Auger	Inspect. Replace both upper bearing and lower bearing if wear exceeds factory recommendations. Replace the mechanical seal if the seal's contact surfaces are worn, cracked, or scratched.

## C. Preparing the Icemaker for Long Storage

### CAUTION

When the icemaker is not used for two or three days under normal conditions, it is sufficient to only move the ice making switch to the "OFF" position. When storing the icemaker for extended time or in sub-freezing temperatures, turn the water off and drain out all water from the water lines and remove the ice from the storage bin. The storage bin should be cleaned and dried. Drain the icemaker water hoses using air or carbon dioxide to prevent damage at sub-freezing temperatures.

#### **1. Remove the ice from the storage bin, drain the water system, and remove the water from the icemaker/water dispenser water supply line:**

- 1) Close the icemaker/water dispenser water supply line shut-off valve and open the icemaker/water dispenser water supply line drain valve.
- 2) Move the dispense mode switch to the "CONTINUOUS" position, then dispense all of the ice from the storage bin.
- 3) Open the drain valve to drain all of the water from the evaporator. Close the drain valve.
- 4) Attach a compressed air or carbon dioxide supply to the icemaker/water dispenser water supply line drain valve.
- 5) While engaging the water dispense switch, blow out the water dispense valve using the compressed air or carbon dioxide supply. After blowing out the water dispense valve, leave the compressed air or carbon dioxide supply flowing. Move the ice making switch to the "ICE" position to open the inlet water valve and briefly blow out the valve. After blowing out the inlet water valve, move the ice making switch to the "OFF" position.
- 6) Close the icemaker/water dispenser water supply line drain valve.
- 7) Turn off the power supply. then remove the front panel and move the power switch to the "OFF" position.
- 8) Remove the storage bin cover. Clean the storage bin liner and the storage bin cover using a neutral cleaner. Rinse thoroughly after cleaning. Replace the storage bin cover and the front panel in their correct positions.