

NO.:	73091
ISSUED:	DEC. 21, 1999
REVISED:	DEC. 17, 2003



**HOSHIZAKI
ICE DISPENSING BIN/
WATER DISPENSER**

**MODEL
DM-90A**

SERVICE MANUAL

IMPORTANT

Only qualified service technicians should attempt to service or maintain the dispensing bin. No such service or maintenance should be undertaken until the technician has thoroughly read this Service Manual.

HOSHIZAKI provides this manual primarily to assist qualified service technicians in the service and maintenance of the dispensing bin.

Should the reader have any questions or concerns which have not been satisfactorily addressed, please call or write to the HOSHIZAKI Care Department for assistance.

HOSHIZAKI AMERICA, INC.
618 Highway 74 South
Peachtree City, GA 30269

Attn: HOSHIZAKI Care Department

Phone: 1-800-233-1940 Technical Service
(770) 487-2331
Fax: (770) 487-3360

NOTE: To expedite assistance, all correspondence/communication **MUST** include the following information:

- Model Number
- Serial Number
- Complete and detailed explanation of the problem

- Please review this manual. It should be read carefully before the dispensing bin is serviced or maintenance operations are performed. Only qualified service technicians should service and maintain the dispensing bin. This manual should be made available to the technician prior to service or maintenance.

CONTENTS

	PAGE
I. SPECIFICATIONS	4
II. GENERAL INFORMATION	5
1. CONSTRUCTION	5
III. INSTALLATION AND OPERATING INSTRUCTIONS	6
1. CHECKS BEFORE INSTALLATION	6
2. LOCATION	6
3. SET UP	8
4. CABINET STAND	8
5. ELECTRICAL CONNECTION AND DISPENSING SWITCHES	9
6. WATER SUPPLY AND DRAIN CONNECTIONS	11
7. FINAL CHECK LIST	12
8. START UP	12
9. PREPARING THE ICE/WATER DISPENSER FOR LONG STORAGE	12
IV. TECHNICAL INFORMATION	13
1. WIRING DIAGRAM	13
V. SERVICE DIAGNOSIS	14
VI. REMOVAL AND REPLACEMENT OF COMPONENTS	15
1. SOLENOID	15
VII. CLEANING AND MAINTENANCE INSTRUCTIONS	16
1. CLEANING INSTRUCTIONS	16
[a] CLEANING PROCEDURE	16
[b] SANITIZING PROCEDURE	17
2. MAINTENANCE	17

I. SPECIFICATIONS

AC SUPPLY VOLTAGE	115/60/1		
AMPERAGE	1.5 A		
MINIMUM CIRCUIT AMPACITY	15 A		
MAXIMUM FUSE SIZE	-		
APPROXIMATE ELECTRIC CONSUMPTION	175 W		
APPROXIMATE STORAGE CAPACITY	Cubelet:	Bin Control-44lbs Manual Fill-72lbs	KM: Bin Control-96lbs Manual Fill-103lbs
EXTERIOR DIMENSIONS (WxDxH)	22.22" x 28.86" x 32.81" (564 x 733 x 833 mm) No 4" Legs		
INTERIOR DIMENSIONS (WxDxH)	N/A		
EXTERIOR FINISH	Plastic front, Stainless Steel sides and back		
INTERIOR FINISH	Galvanized Steel & Plastic		
INSULATION	Polyurethane Foam		
WEIGHT	95lbs (approximate)		
CONNECTIONS - ELECTRIC	120 V Power Cord		
- DRAIN	1/2" NPT Threads		
GEAR MOTOR AGITATOR	60 W / Stainless Steel round bar 16.8" Dia.		
GEAR MOTOR PROTECTION	Thermal Protector (Internal)		
ACCESSORIES - OPTIONAL	4" Legs 4 pcs		
OPERATING CONDITIONS	VOLTAGE RANGE	104 - 127 V	
	AMBIENT TEMP.	45 - 100° F	
DRAWING NO. (DIMENSIONS)	3A0859S		
RECOMMENDED ICEMAKER INSTALLED ON UNIT WITH TOP KIT (OPTION)	N/A		

II. GENERAL INFORMATION

1. CONSTRUCTION

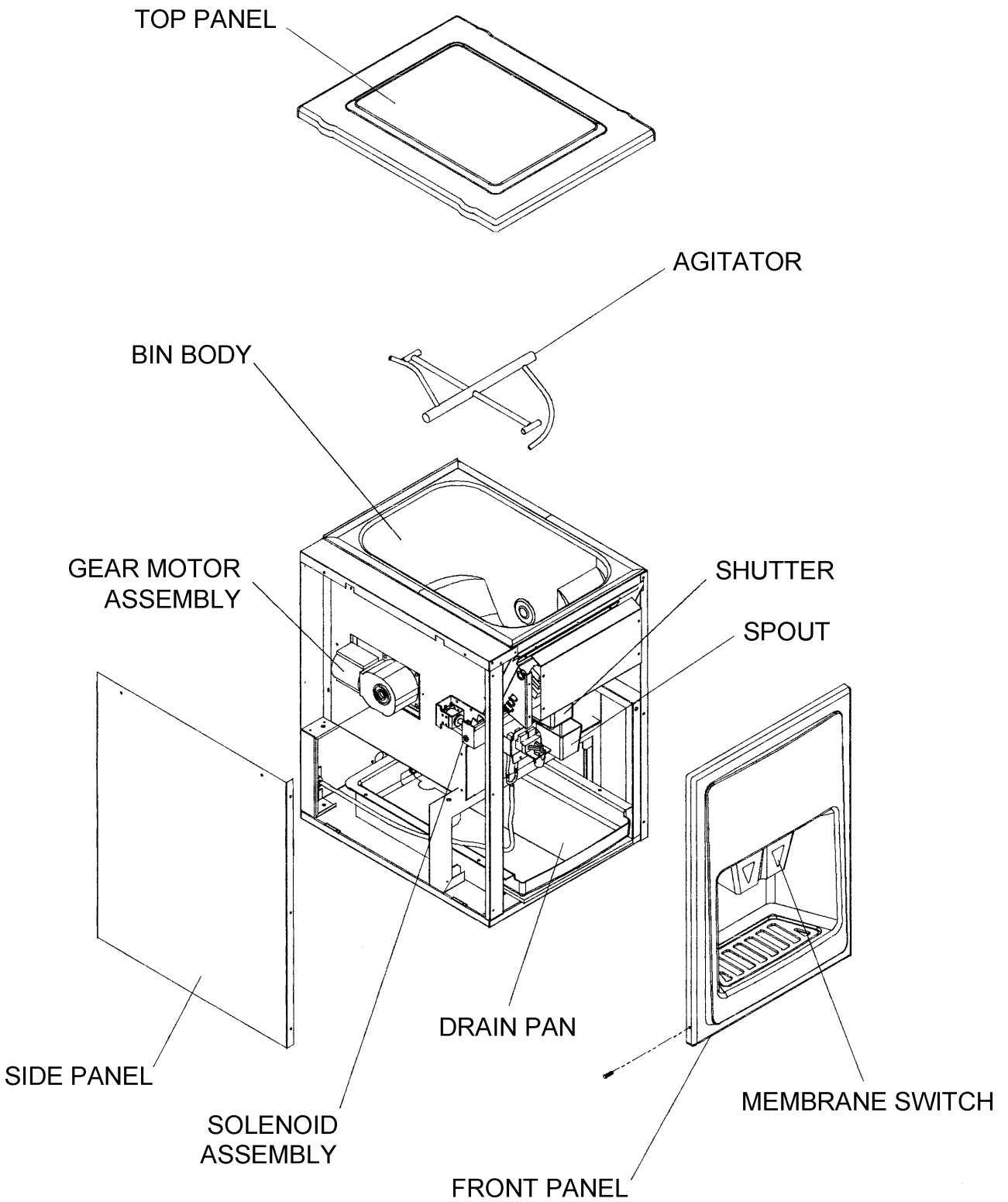

III. INSTALLATION AND OPERATING INSTRUCTIONS

1. CHECKS BEFORE INSTALLATION

IMPORTANT

1. Using this ice dispensing bin in combination with any ice machine cannot be recommended. Inside of bin must be accessible for cleaning.
2. Remove all tape, packing material and shipping cartons from the ice dispenser to prevent possible damage to the machine.
3. Ensure all components, fasteners and thumbscrews are securely in place.

- 1) Remove the Front Panel to prevent damage before installing.
- 2) Remove the package containing the accessories.
- 3) Remove the protective plastic film from the Side Panels. If the ice dispensing bin has been exposed to the sunlight or to direct heat, it should be allowed to cool before removing the protective film.
- 4) Refer to the Nameplate, located on the upper portion of the right Side Panel. Be certain that the voltage supply corresponds with the voltage specified on the nameplate.

2. LOCATION

IMPORTANT

This ice dispensing bin is not intended for outdoor use. Normal operating ambient temperature should be within +45°F to +100°F. Operation of the ice dispensing bin for extended periods, outside of these normal temperature ranges may cause unsatisfactory results.

For best operating results:

- Ice dispensing bin should not be located next to ovens, grills or other high heat producing equipment.
- Location should provide a firm and level foundation for the equipment.
- Always avoid an installation site where dripping is not allowed.

- Allow 6" clearance at rear and sides for ease of maintenance and/or service should they be required. More space is needed especially on the left side of the dispensing bin to service the gear motor.

3. SET UP - See Fig. 1

IMPORTANT

It is especially important that the ice dispensing bin is leveled in both the left-to-right and front-to-rear directions. If it is not level, unsatisfactory performance and/or a reduced rate of ice flow may result.

- 1) Unpack the ice dispensing bin, and remove all shipping cartons, tape(s) and packing before operating the unit. Attach four (4) adjustable legs [adjustable within min. 4" (102 mm) to max. 5" (127 mm)] to the bottom of the ice dispensing bin. Remove the Front Panel to prevent damage, and be careful not to damage the other panels when installing the ice dispensing bin. Remove the screws, and pull up and toward you to remove the Front Panel.

Note: When placing the dispenser on the Cabinet Stand, see "4. CABINET STAND."

- 2) Position the ice dispensing bin in a selected permanent site. Clean and wipe the interior with a clean cloth.
- 3) Level the ice dispensing bin in both the left-to-right and front-to-rear directions.
- 4) Place exterior panels in position on the ice dispensing bin.

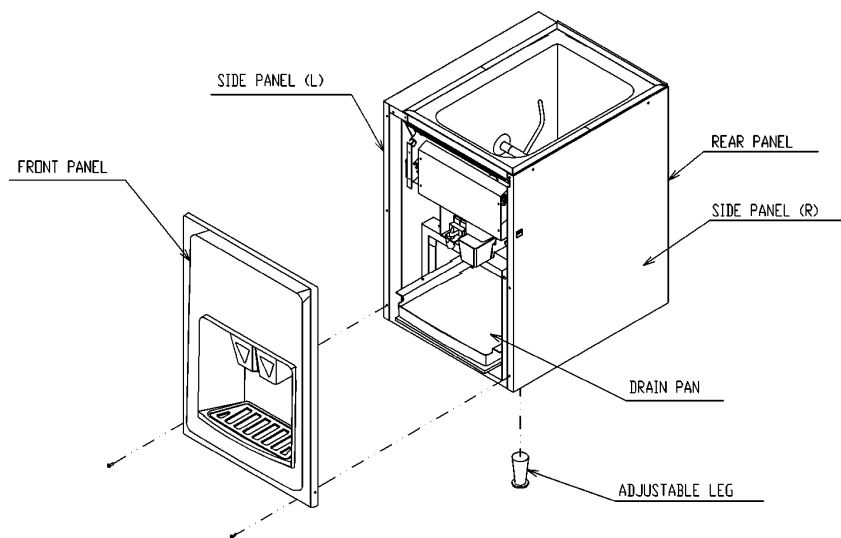

Fig. 1

4. CABINET STAND

When placing the ice dispensing bin on the Cabinet Stand:

- 1) Attach the four (4) adjustable legs to the Cabinet Stand (Cabinet Stand accessory).
- 2) Remove the protective plastic film from the panels.
- 3) Open the Front Door Panel.
- 4) Place the ice dispensing bin on the Cabinet Stand.

Combination: SD-90 DM-90A

- 5) You must secure the ice dispensing bin to the Cabinet Stand with four (4) bolts (Cabinet Stand accessory).
- 6) Seal the seam all around between the dispensing bin and the Cabinet Stand with food grade silicone. See Fig. 2.
- 7) Close the Front Door Panel.

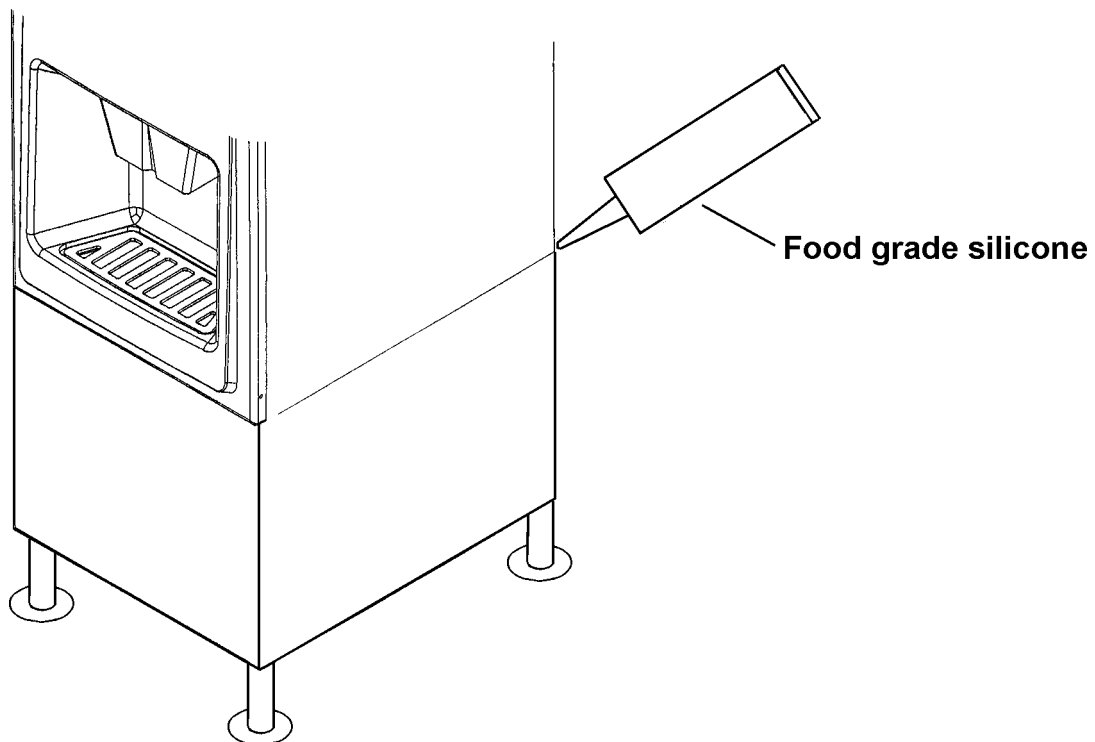

Fig. 2

5. ELECTRICAL CONNECTION AND DISPENSING SWITCHES

WARNING

1. Electrical connection must be made in accordance with the instructions on a "WARNING" tag, provided with the pig tail leads in the Junction Box.
2. To prevent possible electrical shock to individuals or extensive damage to the equipment, install a proper ground wire to the ice dispensing bin that meets local code requirements.

- The white lead must be connected to the neutral conductor of the power source. Miswiring results in severe damage to the ice dispensing bin. See Fig. 3.
- The ice dispensing must have a separate power supply or receptacle of proper capacity. See the Nameplate.
- Check that the ice dispensing switch and the water dispensing switch are operating correctly. See Fig. 4.

Water Dispensing Switch

Push the button, and the unit should operate.
You should hear an operating sound.

Ice Dispensing Switch

Push the button, and the unit should operate.
You should hear an operating sound.

- Usually, an electrical permit and services of a licensed electrician are required.

WARNING

ELECTRICAL CONNECTION

The white lead must be connected to the neutral conductor of the power source.
Miswiring results in severe damage to the icemaker.

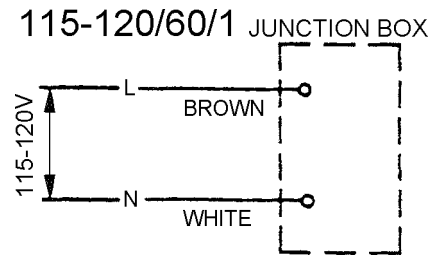

Fig. 3

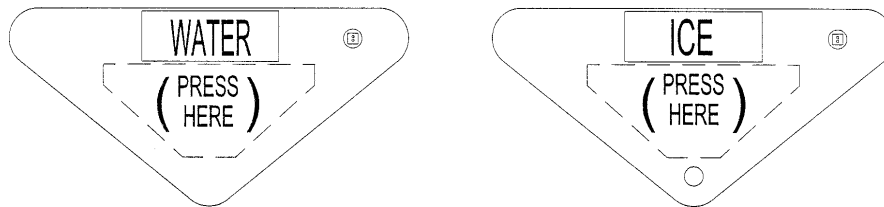

Fig. 4

6. WATER SUPPLY AND DRAIN CONNECTIONS - See Fig. 5

- The water supply inlet is 1/2" female pipe thread (FPT). A strainer should be installed with the clean-out plug facing down. Locate the strainer in the water supply line which is next to the ice dispensing bin. An arrow on the strainer indicates the direction of the water flow.

Note: A Strainer (Hoshizaki Part # 311166A01) is an optional extra.

- A water supply line shut-off valve and drain valve should be installed.
- Water supply pressure should be a minimum of 10 PSIG and a maximum of 113 PSIG. If the pressure exceeds 113 PSIG, use a pressure reducing valve.
- A drain outlet 3/4" FPT is located at the rear of the ice dispensing bin.
- The ice dispensing bin drain connection must be separate from the plumbing of other drains.
- All horizontal runs of drain pipe must have a 1/4 inch drop per foot to promote good drainage.
- Drains should not be piped directly to a sewer system. An air gap of a minimum of 2 vertical inches (5 cm) should be between the end of the ice dispenser drain pipe and the floor drain.
- A back flow preventer may be required in some areas.
- Only cold drinking water should be used for this dispenser.
- A plumbing permit and services of a licensed plumber may be required in some areas.

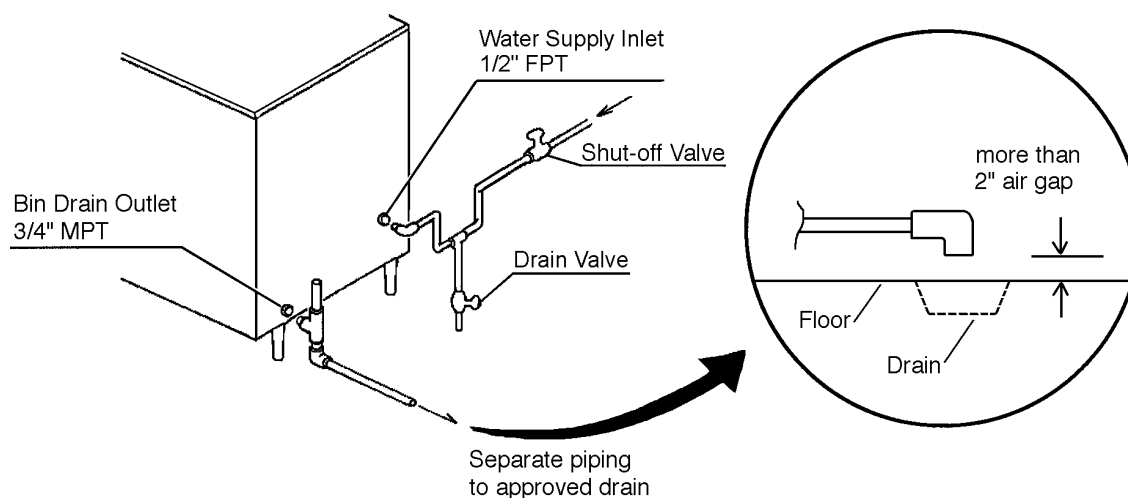

Fig. 5

7. FINAL CHECK LIST

- 1) Is the ice dispensing bin level?
- 2) Is the ice dispensing bin in a site where the ambient temperature is within +45°F to +100°F all year around?
- 3) Is there at least 6" clearance around the ice dispensing bin for easy maintenance and service, and for good ventilation?
- 4) Have all shipping carton, tape(s) and packing been removed from the ice dispensing bin?
- 5) Are all components, fasteners and thumbscrews securely in place?
- 6) Have all electrical and piping connections been made?
- 7) Has the power supply voltage been checked or tested against the nameplate rating? Has proper ground been installed in the ice dispensing bin?
- 8) Has the ice dispensing bin been cleaned and wiped with a clean cloth?
- 9) Has the end user been given the instruction manual, and instructed on how to operate the ice dispensing bin and the importance of the recommended periodic maintenance?
- 10) Has the end user been given the name and telephone number of the contracted service representative?
- 11) Has the warranty tag been filled out and forwarded to the factory for warranty registration?

8. START UP

- 1) Remove the top and use a clean bucket or other clean container for filling the ice dispenser with ice. Reinstall the top.
- 2) Place a cup under the ice or water spout and press membrane switch to dispense.

9. PREPARING THE ICE/WATER DISPENSER BIN FOR LONG STORAGE

CAUTION

Remove all ice from the ice dispenser when preparing it for storage. The dispenser should be cleaned and wiped dry prior to sanitizing.

- 1) Turn the power supply switch off after removing all ice. Unplug the ice dispenser's plug from the power source receptacle.
- 2) The ice dispensing bin should be properly cleaned and wiped dry.

IV. TECHNICAL INFORMATION

1. WIRING DIAGRAMS

(with Brother Gear Motor)

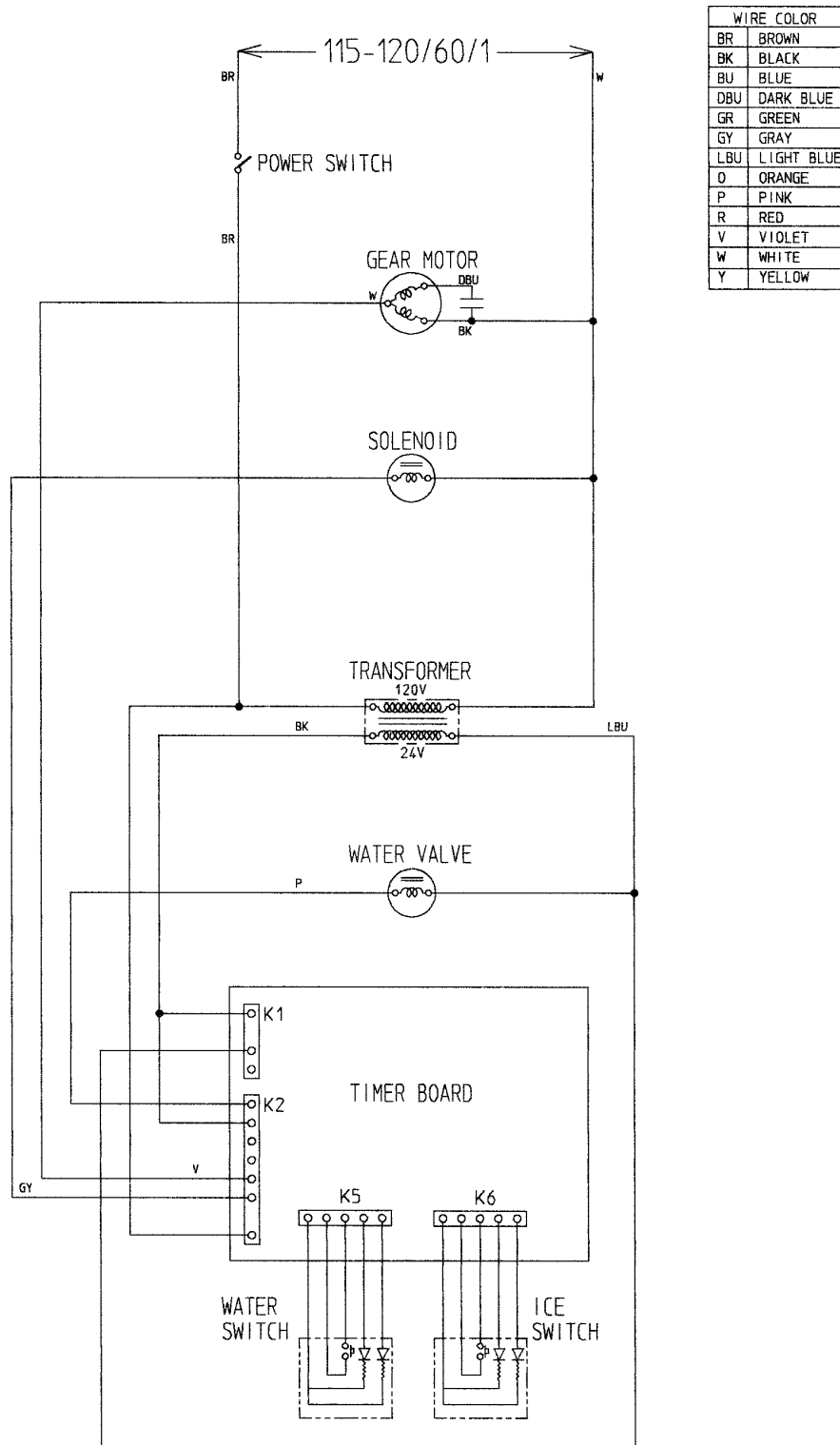

V. SERVICE DIAGNOSIS

PROBLEM	POSSIBLE CAUSE		REMEDY
[1] No ice dispensed.	a) Power Source	1. OFF position.	1. Move to ON position
		2. Loose connection.	2. Tighten
		3. Bad contacts.	3. Check for continuity and replace.
		4. Voltage too high.	4. Check and get recommended voltage.
	b) Ice Dispense Switch	1. Switch is not connected to board	1. Connect to board
		2. Bad contacts.	2. Check for continuity and replace.
		3. Loose connection.	3. Tighten
	c) Gear Motor	1. Thermal protector is tripped.	1. Allow to cool.
		2. Gear Motor winding is opened.	2. Replace
		3. Bearing worn out.	3. Replace.
		4. Wiring to Gear Motor.	4. Check for loose connection or open circuit, and replace wiring as needed.
		5. Defective capacitor.	5. Replace.
		6. Agitator rotates in reverse direction.	6. Check leads and reverse the connections.
	d) Solenoid	1. Solenoid winding open.	1. Replace.
		2. Wiring to Solenoid.	2. Check for loose connection or open circuit and replace wiring as needed.
3. Overload due to loosening screws.		3. After tightening, apply Thread Sealant to the parts.	
e) Ice Storage	1. No ice or little ice in storage bin.	1. Fill ice bin.	
	2. Ice bridge or block formed	2. Break with a poker.	
[2] No water dispensed.	a) Power Source	1. OFF position.	1. Move to ON position
		2. Loose connection.	2. Tighten
		3. Bad contacts.	3. Check for continuity and replace.
		4. Voltage too high.	4. Check and get recommended voltage.
	b) Water dispense switch	1. Switch not connected to board.	1. Connect to board.
		2. Bad Contacts	2. Check for continuity and replace.
		3. Loose Connection	3 Tighten.
	c) Water Valve	1. Wiring to water valve	1. Check for loose connection or open circuit, and preplace wiring as needed.

PROBLEM	POSSIBLE CAUSE		REMEDY
	d) Water Supply	1. Shut-off valve is closed. 2. Drain valve is open.	1. Open valve. 2. Close valve.
[3] Abnormal noise	a) Gear Motor or Gear Head	1. Bearing worn out.	1. Replace.
		2. Grease leaks.	2. Supply grease, and replace O-ring.
	b) Mechanism	1. Bad setting. 2. Bad alignment	1. Apply oil and readjust. 2. Readjust.
		3. Foreign matter interrupting agitator.	3. Remove foreign matter.
c) Solenoid	1. Overload due to loosening screws.	1. After tightening, apply Thread Sealant on the parts.	
	2. Foreign matter on plunger.	2. Clean.	
[4] Ice in storage bin often melts.	a) Bin Drain	1. Foreign matter blocking bin drain.	1. Remove foreign matter.

VI. REMOVAL AND REPLACEMENT OF COMPONENTS

IMPORTANT

Ensure all components, fasteners and thumbscrews are securely in place after the equipment is serviced.

1. SOLENOID

- 1) Turn off the power supply.
- 2) Remove the Front Panel and the Left Side Panel.
- 3) Disconnect the connectors from the Solenoid leads, and remove the Solenoid Assembly.
- 4) Remove the Solenoid, and install a new Solenoid. Securing torque should be 13–17.3 in. lb.
- 5) Assemble the removed parts in the reverse order of the above procedure.
- 6) Turn on the power supply.

VII. CLEANING & MAINTENANCE INSTRUCTIONS

IMPORTANT

Ensure all components, fasteners and thumbscrews are securely in place after any maintenance or cleaning is done to the equipment.

1. CLEANING INSTRUCTIONS

CAUTION

1. HOSHIZAKI recommends cleaning this unit at least once a year. (See the "CLEANING INSTRUCTIONS" on the icemaker.) More frequent cleaning, however, may be required in some existing water conditions.
2. To prevent injury to individuals and damage to the ice dispensing bin, do not use ammonia type cleaners.
3. Always wear liquid-proof gloves for safe handling of the cleaning and sanitizing solution. This will prevent irritation in case the solution contacts the skin.

[a] CLEANING PROCEDURE - See Fig. 6 on following page

- 1) Clean and sanitize the ice dispensing bin as conditions require.
- 2) Remove all ice from the Bin.
- 3) Disconnect electrical power to the ice dispensing bin.
- 4) Remove the Front Panel to allow access to the Chute Assembly for cleaning.
- 5) Scrub inside of the Bin, the Agitator, the Spout of the Bin, the Spout of the Front Panel and the Chute using a nylon scouring pad, brushes and cleaning solution, such as 5 oz. Hoshizaki "Scale Away" or Lime-A-Way (Economics Laboratories Inc.), in one gallon of water.
- 6) Scrub the Shutter Assembly and the Spout using the cleaning solution made in step 5). See Fig. 6 on the following page.
 - a) Remove the snap pin and shift the shaft to the right.
 - b) With snap pin removed, removal of Shutter Assembly (A) can now be accomplished.
- 7) Rinse all parts thoroughly with clean water.

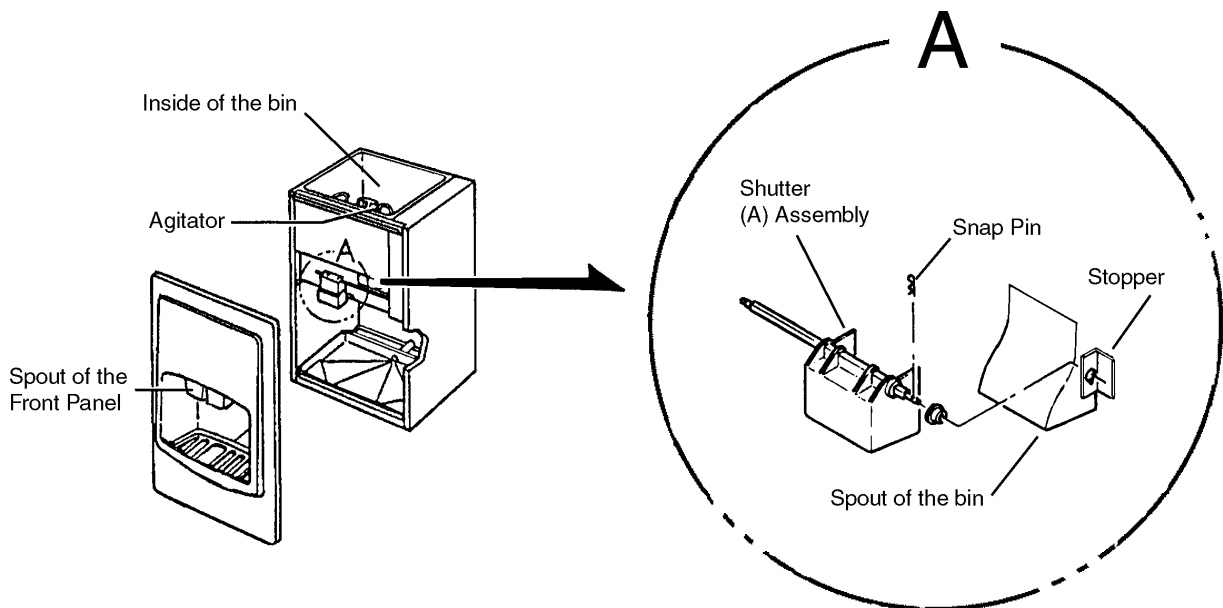

Fig. 6

[b] SANITIZING PROCEDURE - Following Cleaning Procedure

- 1) Wash all parts in steps 5) and 6) using the following sanitizing solution: 1/2 fl. oz. of a 5.25% sodium hypochlorite solution (chlorine bleach) in 1 gallon of water.
- 2) Rinse all parts thoroughly with clean water.
- 3) Reassemble in the reverse order of the removal procedure.
- 4) Turn on the ice dispensing bin.
- 5) Check for proper operation. (See the "ELECTRICAL CONNECTION" instructions.)

2. MAINTENANCE

1) Exterior Panels

To prevent corrosion, wipe occasionally with a clean, soft cloth. Use a damp cloth containing a neutral cleaner to wipe off oil or dirt build up.

2) Periodic Maintenance

Due to the simple design of this ice dispensing bin, and the relatively short operating time, very little maintenance is required.