



# HOSHIZAKI

## Instruction Manual

Water Dispenser  
MODwater™ Series

Model:  
DWM-20A



[hoshizakiamerica.com](http://hoshizakiamerica.com)

# Table of Contents

<b>INTRODUCTION .....</b>	<b>3</b>
<b>Contents .....</b>	<b>3</b>
<b>Installation Kit Contents .....</b>	<b>6</b>
<b>Product Specifications .....</b>	<b>7</b>
<b>Safeguards .....</b>	<b>9</b>
<b>Instructions .....</b>	<b>10</b>
<b>INSTALLATION.....</b>	<b>11</b>
<b>Step-By-Step Set Up .....</b>	<b>11</b>
<b>Installation on AM-50/C-80 Ice Makers .....</b>	<b>23</b>
<b>OPERATION.....</b>	<b>28</b>
<b>MAINTENANCE .....</b>	<b>30</b>
<b>Empty Drain Pan.....</b>	<b>30</b>
<b>CO<sub>2</sub> Tank Replacement.....</b>	<b>31</b>
<b>Cleaning and Sanitation .....</b>	<b>31</b>
<b>Electrical System.....</b>	<b>39</b>
<b>Transporting and Relocating .....</b>	<b>40</b>
<b>TECHNICAL SUPPORT.....</b>	<b>41</b>
<b>Troubleshooting .....</b>	<b>41</b>
<b>Leak Detector Troubleshooting .....</b>	<b>43</b>
<b>Support.....</b>	<b>43</b>
<b>Recycling Program.....</b>	<b>43</b>
<b>WARRANTY CONDITIONS .....</b>	<b>44</b>

# INTRODUCTION

## Contents

MODwater™ Dispenser Model DWM-20A

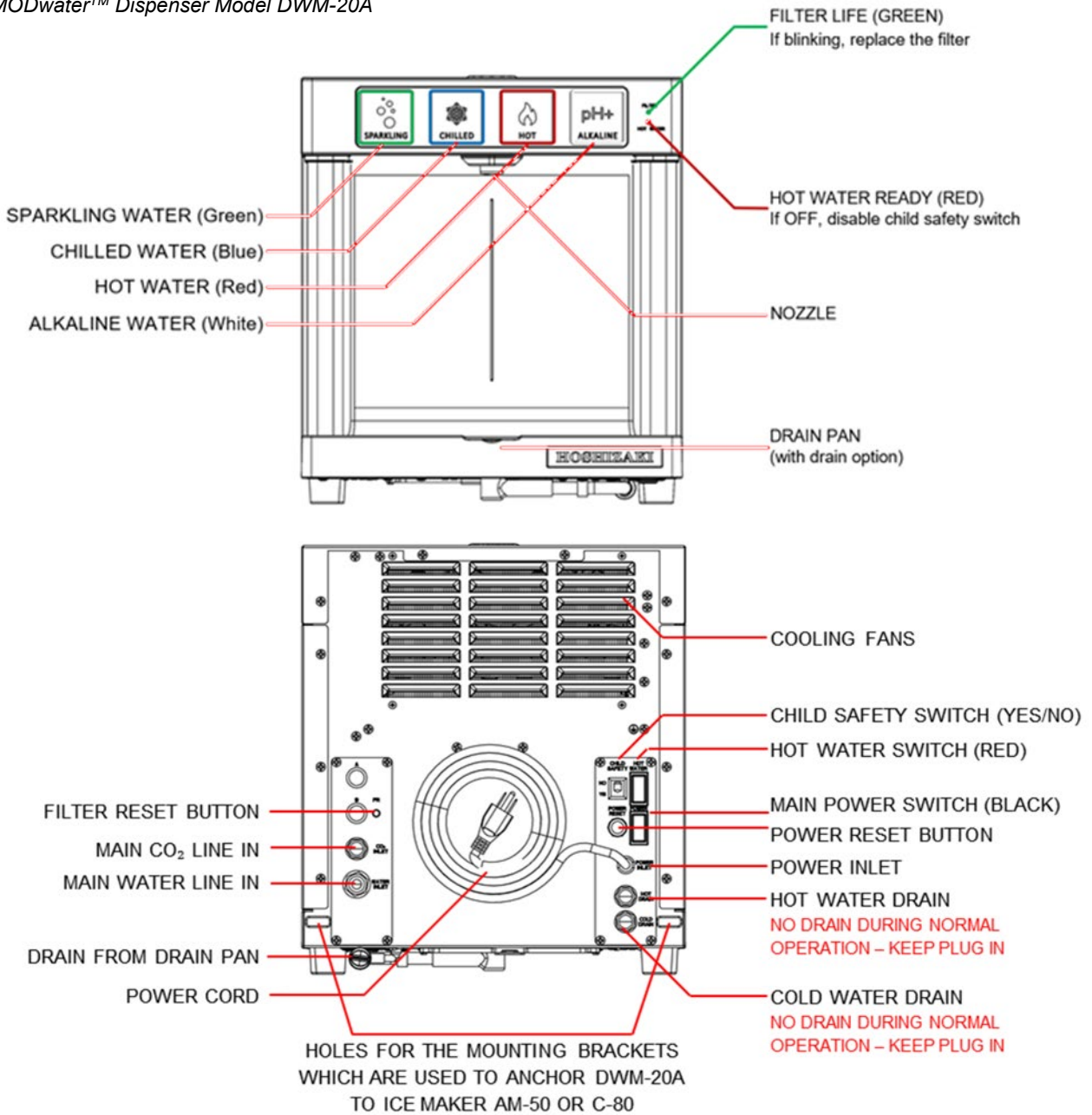

- DURING INSTALLATION, KEEP THE PLUGS (STEMS) INSIDE BOTH COLD AND HOT DRAINS  
Cold and hot water drains should ONLY be unplugged before transporting your MODwater dispenser.



- DO NOT FLUSH FILTERS THROUGH THE DWM-20A DISPENSER  
Flush or wash the filters with a separate line. Flushing the filters through the dispenser may cause the internal valves to be compromised and fail. Your warranty will be invalidated.

# Congratulations on your purchase!

Thank you for choosing HOSHIZAKI MODwater™ model DWM-20A.

The DWM-20A has the following main characteristics and features:

**Multiple Options:** From the left to the right: chilled sparkling water, chilled still water, hot water and cold alkaline water.

**Fast:** It fills bottles in seconds.

**Child Safe:** Avoids accidental dispensing of hot water (by enabling the Child Safety Switch).

**Energy Saving:** It enters stand-by mode – with button lights off, if not frequently used.

**Thermal Energy Saving Switch:** Turn the hot water power off if not used daily.

**Alkaline Chamber:** Mineral chamber included inside the dispenser.

## **IN ORDER TO INSTALL DWM-20A DISPENSER, YOU NEED:**

- 1. Installation Kit: (included) a set of items for proper installation of this dispenser (see page 6).**
- 2. Carbon Dioxide Tank (Not included): external to this dispenser (see page 8).**

## **NOTICE**

- Read the instructions in this Manual and retain for future reference.
- Product failure due to improper installation is NOT covered by the Warranty.
- The DWM-20A is for indoor use only. Do not install it outdoors.
- Due to rigorous testing performed by the Manufacturer on each of its products, the DWM-20A may contain reasonable traces of liquid sanitizing solution inside.
- **SLEEP MODE.** After one hour of inactivity, DWM-20A enters SLEEP MODE to reduce energy consumption, and all 4 touch buttons are off. To wake it up, just touch and release your finger on any of the four buttons.
- **SAFETY MODE.** The green and red LED indicators are both blinking while all touch buttons are off. To prevent accidental dispensing the DWM-20A automatically stops if more than 0.4 gallon (i.e. 1.5L) of water is dispensed continuously, or if a button is touched for more than 30 seconds without pausing. It also stops if there is little or no water in the pipeline flowing to the DWM-20A, or there is an internal leak. To restart it, switch main power off and, after just 3 seconds, turn it on again.
- **ENERGY SAVING.** DON'T NEED HOT WATER OFTEN? Turn Hot Water Switch (RED) off and enable Child Safety Switch (turn it to the "YES" position). Otherwise, if you don't dispense hot water at least once per month, the DWM-20A automatically switches hot water power off, to save energy. To get hot water again, just touch and hold the red touch button for 15 seconds.

## **▲ WARNING**

- Connect DWM-20A to city potable water only.
- Check and comply with all local plumbing codes when performing installation.
- Check the water inlet pressure. While the dispenser is designed to withstand 80 psi maximum inlet water pressure, the recommended inlet water pressure is 60-65 psi. Always use a water pressure regulator (included in the installation kit) to reduce the water pressure down to 60-65 psi.
- For sparkling water, only use carbon dioxide UN 1013 Food Grade.
- Fill water into the Hot Water Tank before switching the heater. Do not keep the heater on (i.e. by turning the red hot water switch to on) if you do not dispense hot water at least once per month. Save energy.
- Once the water dispenser has been installed, DO NOT MOVE IT and DO NOT TILT IT.
- If you need to move the water dispenser to another location, please check specific instructions found on page 40.

## **▲ WARNING**

Only qualified service technicians should install and service the water dispenser. To obtain the name and phone of your local Hoshizaki Certified Service Representative, visit [www.hoshizakiamerica.com](http://www.hoshizakiamerica.com). No installation or service should be undertaken until the technician has thoroughly read this Instruction Manual. Likewise, the owner/manager should not proceed to operate the water dispenser until the installer has instructed them on its proper operation. Failure to install, operate, and maintain the water dispenser in accordance with this Manual will adversely affect safety, performance, component life, and warranty coverage and may result in costly water damage. Proper installation is the responsibility of the installer. Product failure or property damage due to improper installation is not covered under warranty.

Hoshizaki provides this Manual primarily to assist qualified service technicians in the installation, maintenance, and service of the water dispenser.

# Installation Kit Contents

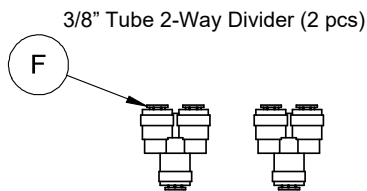
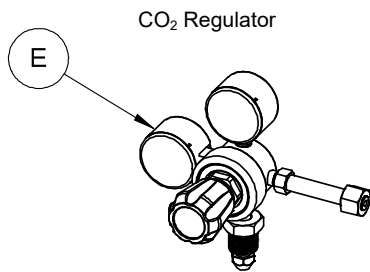
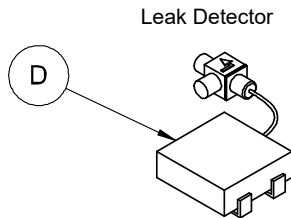
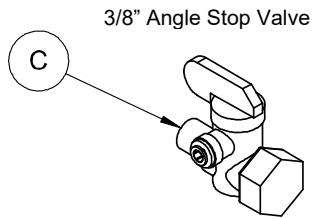
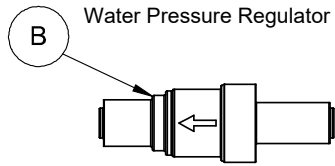
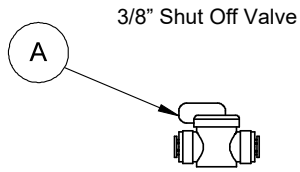

All-in-One Filters (2 pcs) HS-5441

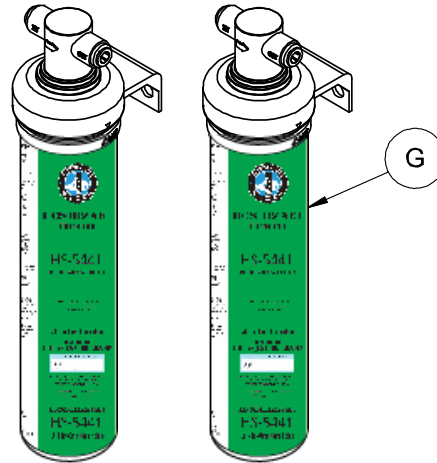

Alkaline Chamber HS-5442

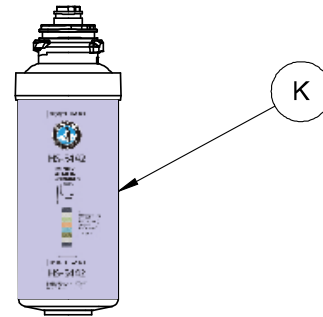

3/8" Tube (20 ft.) for Water Inlet

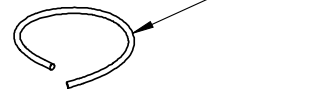

1/4" Tube (15 ft.) for CO<sub>2</sub> Inlet

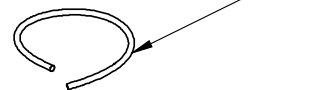

Red Collet Locking Clip 1/4" and 3/8"

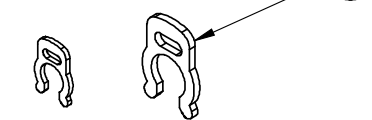

x5 PCS

x20 PCS

## Product Specifications

Dimensions	14 <sup>7</sup> / <sub>8</sub> " W x 21 <sup>1</sup> / <sub>2</sub> " D x 16 <sup>5</sup> / <sub>8</sub> " H
Dry / Wet Weight	72 lb. / 93 lb.
Electrical Rate	120 V / 60 Hz (Single Phase)
Maximum Current	9 A
Ambient Working Temperature	41 – 90 °F
Inlet Water Temperature	41 – 85 °F
<b>Recommended Inlet Water Pressure</b>	<b>45 PSI (min) - 65 PSI (max)</b>
<b>Recommended Inlet CO<sub>2</sub> gas Pressure ✕</b>	<b>50 PSI (min) to 65 PSI (max) ✕</b>
Water Filters Capacity	6000 Gal
Mineral Alkaline Chamber Capacity	1000 Gal

✕For fine tuning of carbonation level in sparkling water, see table at page 29.

PERFORMANCE CHARACTERISTICS OF MODEL DWM-20A		
SECTION	PARAMETER	VALUE
REFRIGERATION SYSTEM	Max Draw Capacity	up to 0.9 Gal/minute (chilled water)
	Max Cooling Capacity ( $\Delta T = 10^{\circ}F$ )	20 Gal/h - Normal Ambient Conditions
	Max Volume of Chilled Water (< 40°F)	6.8 Gal/h - Normal Ambient Conditions
	Max Volume of Chilled Water (< 40°F)	5.0 Gal/h - Hot Ambient Conditions
CARBONATION MECHANISM	Max Carbonation (inlet water at 65 psi)	3.6 vol. - avg. 7.2 g/L – Normal Ambient Conditions
HOT WATER SYSTEM	Max Dispensing Vol. at > 170°F (up to 195°F)	1.8 Gal/h Normal Ambient Conditions
	Max Dispensing Vol. at > 170°F (up to 195°F)	1.3 Gal/h Cold Ambient Conditions
	Time Interval for constant hot water temp 1 mug (8oz.)	2:30 minutes Normal Ambient Conditions
ALKALINE CHAMBER	Max quantity of minerals dissolved in water	40 ppm
	Maximum pH (after 72 hours of rest)	10.1 pH
	Average Alkaline pH	8pH to 9pH
	Type of Minerals/Electrolytes	K, Ca, Mg, Fe, Mn, P, Na, Zn

Normal Ambient	Incoming water at a temperature of 75°F	Room temperature of 75°F
Hot Ambient	Incoming water at a temperature of 85°F	Room temperature of 90°F + 65% humidity
Cold Ambient	Incoming water at a temperature of 41°F	Room temperature of 41°F

NOTICE: the performance of DWM-20A varies based on several variables including, in particular, the temperature of the incoming water and the ambient (i.e. room) temperature. Find above three different temperature settings characterizing Normal, Hot and Cold ambient conditions. The performance of water dispensers also depends upon the size of the cup or the bottle used and the sequence of dispensing (i.e. the interval of time between multiple dispensing). This dispenser has been submitted to tests based on the standards published on [www.waterdispenserstandard.com](http://www.waterdispenserstandard.com).



## Dimensions of the 3 largest components to be installed:

### 1. CO<sub>2</sub> Gas Tank – UN1013 Food Grade – (Not included)

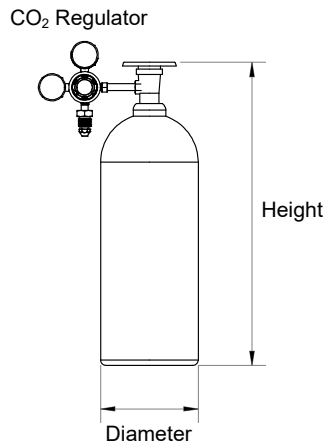

To be positioned under the counter, or at any location no more than 30 ft from the DWM-20A dispenser.

SIZE	DIAMETER	HEIGHT
20 lb. Tank	9 in.	28 in.
10 lb. Tank	7 in.	22 in.
5 lb. Tank	7 in.	17 in.

### 2. Model DWM-20A

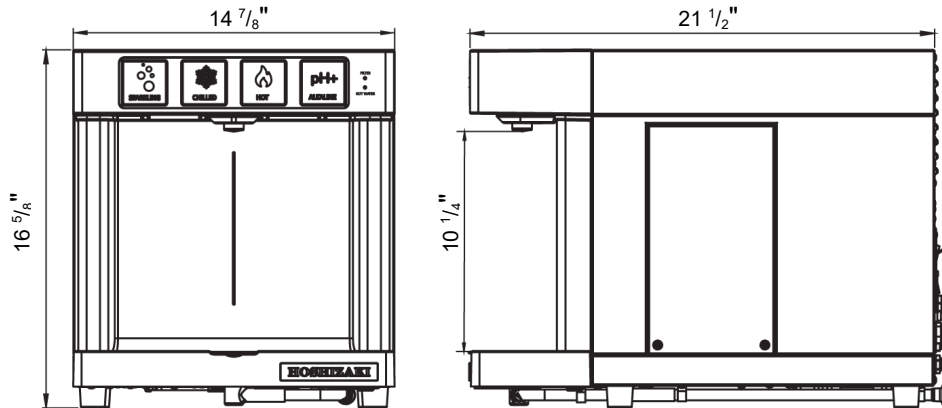

#### NOTICE

for proper ventilation allow at least 4" of space at the rear and sides of DWM-20A. If not possible, refer to: [www.hoshizakiamerica.com](http://www.hoshizakiamerica.com) website for alternative installation solutions.

To be positioned on any countertop, or on top of an AM-50 / C-80 HOSHIZAKI ice maker.

### 3. All-in-One filters (2 pcs.) – HS-5441 – (Included)

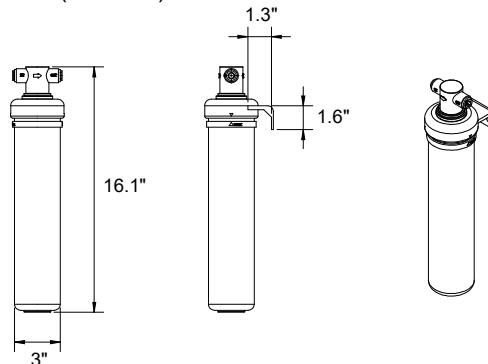

To be positioned under the sink, or at any location near to the main water line, no more than 10 ft. from DWM-20A.



## Safeguards

**WARNING:** TO REDUCE THE RISK OF ELECTRIC SHOCK, FIRE AND/OR PERSONAL INJURY, PLEASE READ THIS INSTALLATION MANUAL CAREFULLY.

1. Connect and operate the DWM-20A only in accordance with the specifications shown on the label located at the back of the DWM-20A model and in this Installation Manual.
2. Do not immerse the electric power cord, the plug, or the DWM-20A in water. Do not plug the DWM-20A into a household extension cord. It must be plugged directly into an electrical wall outlet (110/120 VAC, 60Hz, 20 Amps).
3. Do not operate the DWM-20A with a damaged electric power cord or a damaged plug. In the event the DWM-20A malfunctions, or is dropped or damaged in any manner, unplug it immediately and return it to the manufacturer for repair.
4. Do not place the DWM-20A, its electric cord, or plug on or near stoves or other hot surfaces.
5. Always unplug the electric power cord when the DWM-20A is not in use for an extended period, when it is relocated, or before cleaning it.
6. Leave at least a 4-inch gap on all lateral sides between the DWM-20A and the wall to assure sufficient air circulation for proper ventilation and efficient cooling of the water dispenser's refrigeration system. Do not install the DWM-20A inside a cabinet because without proper air-circulation the water dispenser's refrigeration system will fail. Alternative installation solutions are possible: refer to [www.hoshizakiamerica.com](http://www.hoshizakiamerica.com) to find out more.
7. Children and people with mental disabilities must be supervised by a person who is responsible for their safety when using the DWM-20A, because it can dispense water at a very high temperature. ADULT SUPERVISION REQUIRED.
8. To avoid potential hazards and personal injury, never attempt to open/disassemble the DWM-20A by unscrewing panels/covers: there are no user-serviceable parts inside! In case of malfunction, call the Manufacturer using the toll-free customer service line. Repairs of DWM-20A must only be performed by the Manufacturer or its qualified service personnel to avoid potential hazard and electric shocks. The Manufacturer warranty will be automatically invalidated if non-authorized personnel service the DWM-20A. Call toll-free at 1 (800) 233-1940.
9. Any use of non-original parts (i.e. parts not provided by the Manufacturer), including third-party parts, could lead to a permanent malfunction or a failure of the DWM-20A, property damage and/or personal injury, including death.
10. Using third-party filters or other filtration systems for the DWM-20A water dispenser other than original filters may result in a permanent malfunction of the dispenser and may also cause personal injury. Furthermore, it will invalidate the manufacturing warranty on the DWM-20A.
11. If any component of the DWM-20A is misused or used incorrectly, the water dispenser may fail and cause property damage and personal injury, including death from electric shock. Misuse of the DWM-20A may cause deterioration of the quality or contamination of the materials used in the DWM-20A. Connecting the water dispenser to a supply of contaminated water may result in serious personal injury. Only connect the DWM-20A, through its own external filtration system, to a potable water supply.
12. Water pipe connections and fixtures directly connected to a potable water supply shall be seized, installed, and maintained in accordance with federal, state, and local codes.

## Instructions

1. Make certain that installation of the DWM-20A model complies with all federal, state and local laws and regulations as well as with your building codes, office/apartment or condo provisions, rules or regulations.
2. In the installation of DWM-20A you must only use HS-5441 filtration system. The Manufacturer is not responsible for any misuse or modification of HS-5441 filtration system and accepts NO liabilities if the DWM-20A is used with different filtration systems. In addition, the use of non original filters invalidates the Manufacturer
3. on the DWM-20A water dispenser.
4. Do not connect the DWM-20A dispenser and its filtration system to a water supply that is microbiologically unsafe or of unknown quality without adequate pre-treatment and disinfection. Connect HS-5441 filtration system to the city potable water only.
5. If the DWM-20A is left unused for more than 3 days, dispense at least one bottle of water from each water type. If left unattended for more than 30 days, replacement of its filtration system and of its alkaline chamber is recommended before starting to use the DWM-20A again.
6. The DWM-20A dispenser must be connected to a cold water supply with a pressure of at least 45 psi measured on a 3/8" section tube. A very low external water pressure (at or below 40 psi) or a very low water flow rate (below 1 gallon/minute) will significantly reduce or hamper the performance of the DWM-20A and its ability to properly carbonated sparkling water. If the water pressure is low, please use the booster pump as indicated in the Parts Manual (order separately).
7. The DWM-20A is designed to operate up to the maximum allowed water pressure for a residence or a commercial building, which is 80 psi (552 kPa). However, the recommended maximum water pressure is 60-65 psi. To reduce the water pressure, use the water pressure regulator provided in the installation kit.
8. Do not use the DWM-20A outdoors. The recommended room temperature, for indoor use, is comprised between 41°F and 90°F.
9. When the filtration system indicator (green light – top right) starts blinking (on/off) it means that the HS-5441 filters and the HS-5442 alkaline chamber have reached the end of their lifespan, and MUST be changed in order to prevent quality deterioration of your drinking water and/or clogging of the system. It is recommended to replace the HS-5441 filters and the HS-5442 alkaline chamber as soon as possible when the green light indicator starts blinking or every 6 months, whichever comes first.

DUE TO THE FACT THAT THE MANUFACTURER MAY NOT KNOW THE QUALITY AND THE PERFORMANCE CHARACTERISTICS OF ANY POSSIBLE ALTERNATIVE FILTRATION SYSTEMS IN THE MARKET, PLEASE NOTE THAT THE MANUFACTURING WARRANTY OF THIS DISPENSER BECOMES NULL AND VOID SHOULD YOU USE FILTER(S) OTHER THAN THE HS-5441.

# INSTALLATION

## Step-By-Step Set Up

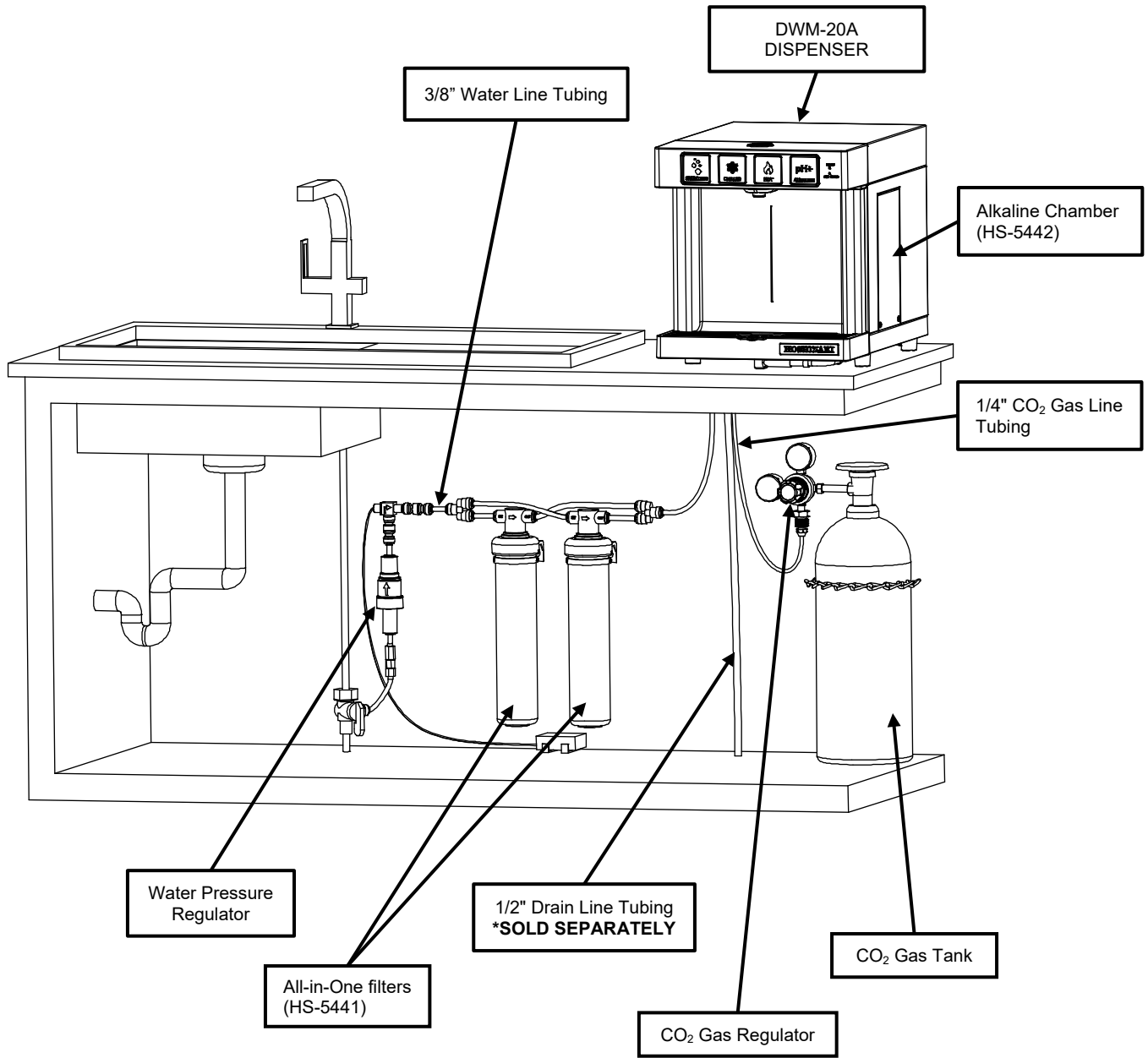

COMPLETED INSTALLATION ON A COUNTERTOP

General Instructions:

- The DWM-20A model is designed to be located on any countertop, or on a Hoshizaki C-80/AM-50 ice maker as indicated on the following section (see page 23).
- In case of installation on a counter, the DWM-20A must be placed on a sturdy, uniform surface capable of withstanding, at least, 93 lb. of weight. A kitchen countertop is an ideal place. Unpack the DWM-20A model and place it on a counter, next to an electrical power outlet, exactly where it is supposed to be permanently installed.
- Locate a water line within 10 feet of the DWM-20A. Make sure the water supply you intend to connect the DWM-20A to is cold and is not coming from a water heater or boiler.
- Allow 4" of space at rear and sides of DWM-20A for better ventilation. Never place the DWM-20A inside a closed cabinet without proper ventilation. In case this requisite may not be fulfilled, go on [www.hoshizakiamerica.com](http://www.hoshizakiamerica.com) web site for alternative installation solutions.
- **IMPORTANT:** Before beginning the installation process, insert the alkaline chamber (K) by unscrewing the lateral panel of the DWM-20A. Refer to diagrams on pages 36 and 37 for details about how to perform this operation.
- The All-in-One filtration system (included) and the CO<sub>2</sub> gas tank (not included) should be installed under the counter.
- In order to connect the dispenser to its external filtration system (with the 3/8" flexible plastic tube provided in the installation kit) and to the CO<sub>2</sub> gas tank (with the 1/4" flexible plastic tube provided in the installation kit), a 3/4" hole might be necessary to be drilled on the countertop, in a location corresponding to the back of the dispenser.

List of Necessary Tools (Not Provided):

Tube Cutter

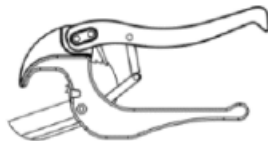

Screwdriver



Tongue and Groove Pliers

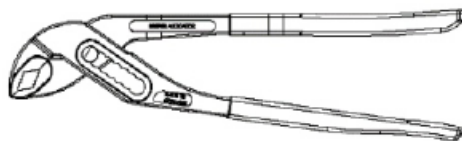

Electric Drill 1/8" Drill Bit and, for granite, a Milwaukee One-Piece Hole Saw Diamond plus 3/4" & 1/2"



Adjustable Wrench



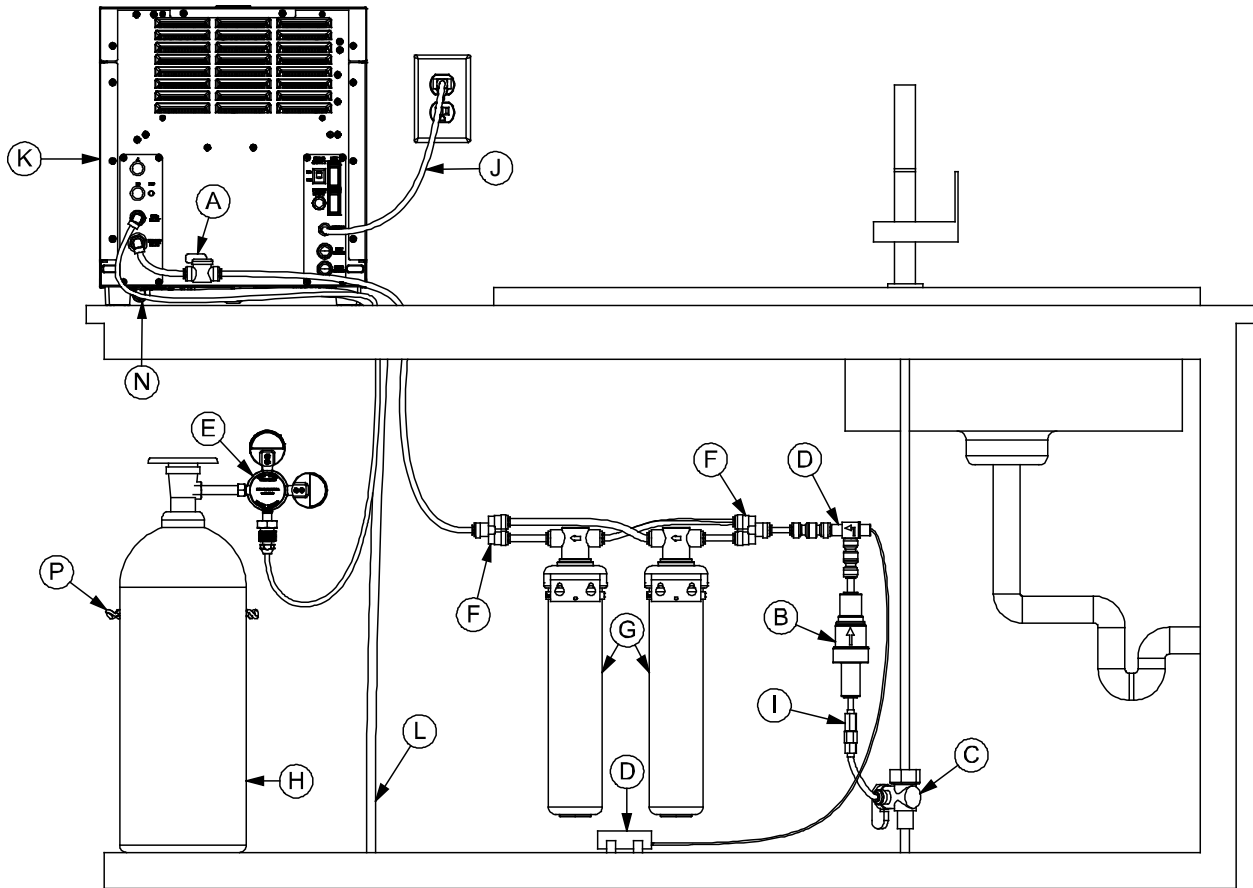

**BACK VIEW OF A COMPLETED INSTALLATION ON A COUNTERTOP**

- A. 3/8" Manual shut off valve
- B. 65PSI 3/8" Pressure regulator
- C. 3/8" Angle stop valve
- D. Leak Detector
- E. Double Gauge CO<sub>2</sub> Regulator
- F. 3/8" Tube 2-way Divider
- G. Double All-in-One Filter
- H. CO<sub>2</sub> Gas Tank
- I. Flow Prevention Valve (ASSE 1032)
- J. Power Cord
- K. Alkaline Chamber
- L. 3/8" Drain Tube
- M. 3/8" Water Tube
- N. 1/4" CO<sub>2</sub> Tube
- O. Red Collet Locking
- P. CO<sub>2</sub> Tank Restraint

Red Collet Locking Clip 1/4" and 3/8"

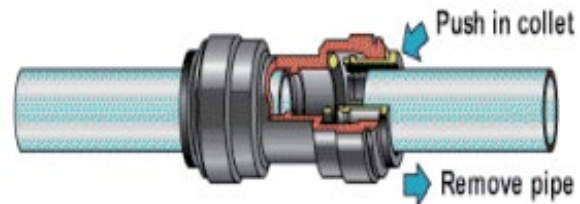
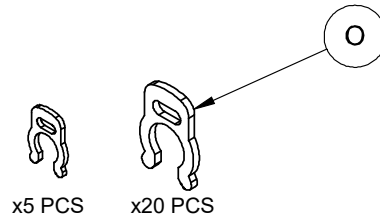

Lock each John Guest Quick Connect with Collet Locking Clip

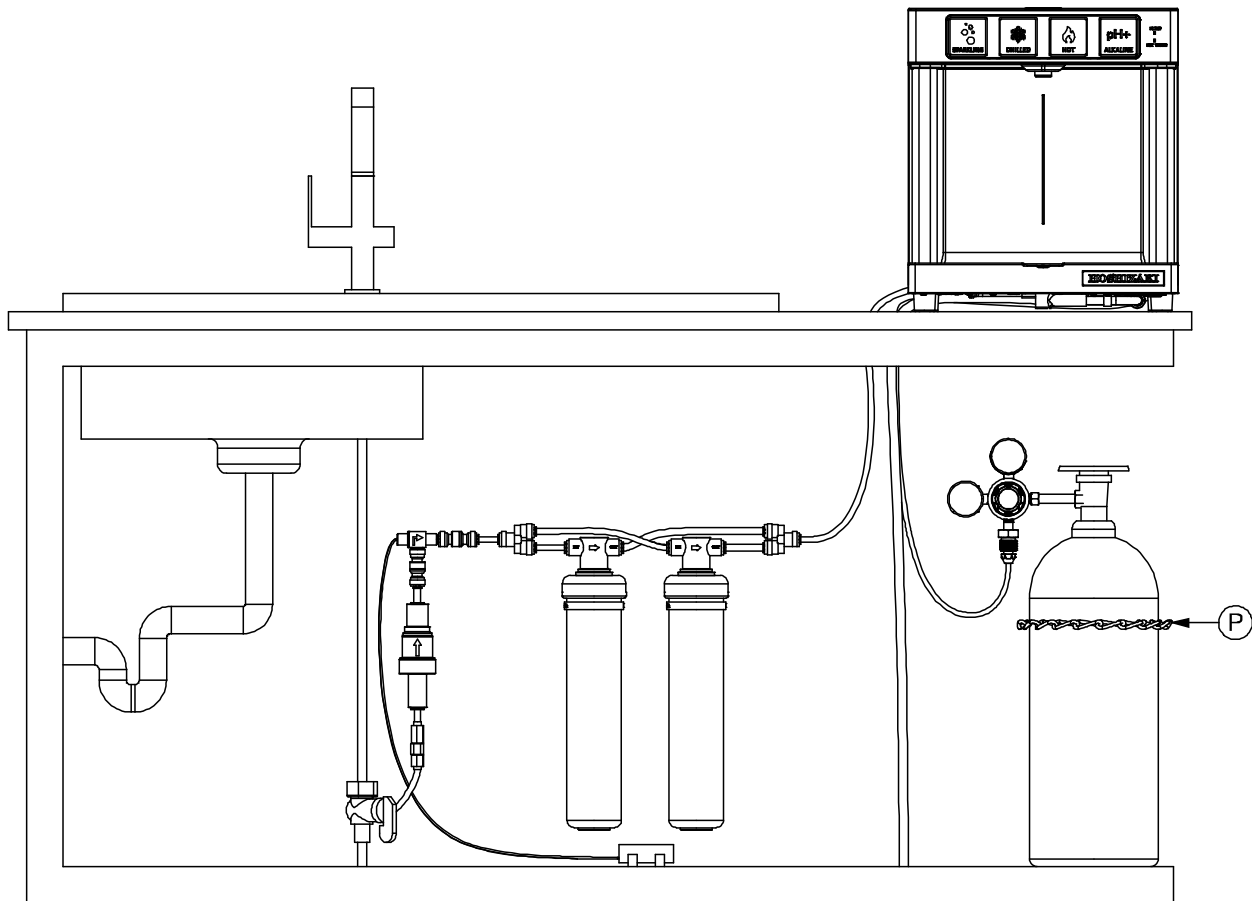

**FRONT VIEW OF A COMPLETED INSTALLATION ON A COUNTERTOP**

- Unpack the two All-in-One filters. Procure the CO2 gas tank from a local CO2 supplier of choice. Make sure that the CO2 tank is labeled Carbon-Dioxide UN1013 Food Grade. Check that there is sufficient space under the counter to place all the components of the installation kit as listed on page 6. Otherwise select another suitable location for either the filters or the CO2 tank. Filters and/or CO2 tank can be located several feet away from the dispenser (DWM-20A unit) (see page 8). Before starting, check dimensions of largest components on page 8.



CO<sub>2</sub> Tank Restraint  
(Not Included)

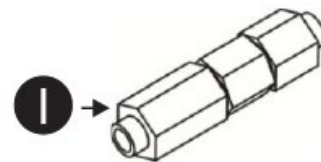

Backflow Prevention Valve ASSE 1032  
(Not Included)

- **IMPORTANT:** connect the drain pan. The drain pan comes connected to a drain pipe that runs underneath the dispenser and can be connected to a drain by a flexible plastic tube connected to the back of the DWM-20A dispenser. If there is not enough downward slope for the drain line, please install an accessory drain pump to ensure water does not back-up in the drain line. Remove the two (2) black rubber plugs at the bottom of the drain pan and at the end of the drain tube.
- Alternatively, if the location where the dispenser is installed has no drain, you can go “drainless” and use the drain pan as a “drip tray.” You must detach the metal pipe underneath the drain pan (by pushing down the silicon connector) and leave the plug at the bottom of the drain pan. The drain pan must be emptied periodically, or when it is full. NOTE: Please be sure not to pour non-water liquids in the drain pan as they can create unsanitary conditions.
- The DWM-20A drain pan can be connected to a drain through a flexible plastic tube (1/2”) as per picture (not included).

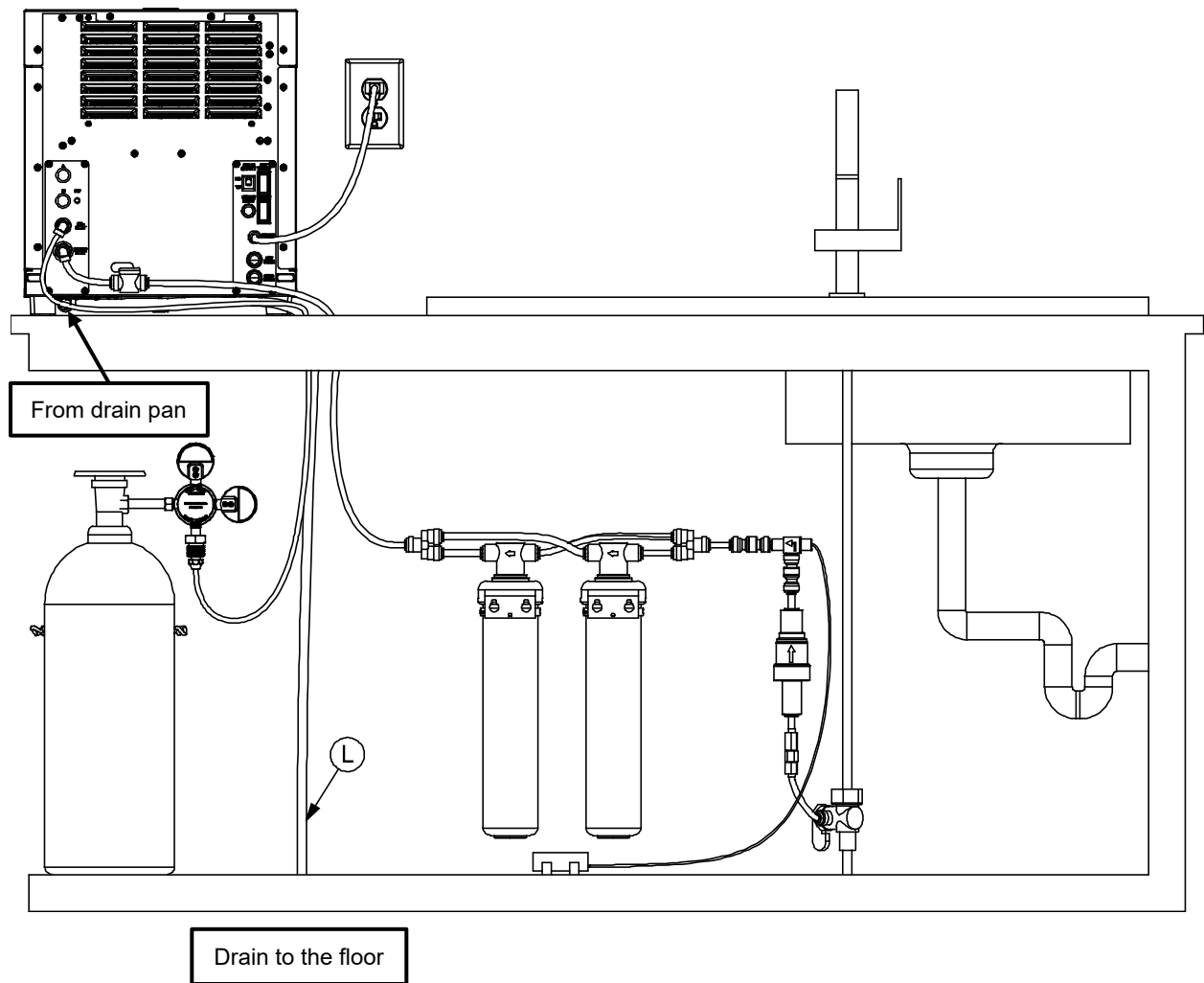

BACK VIEW

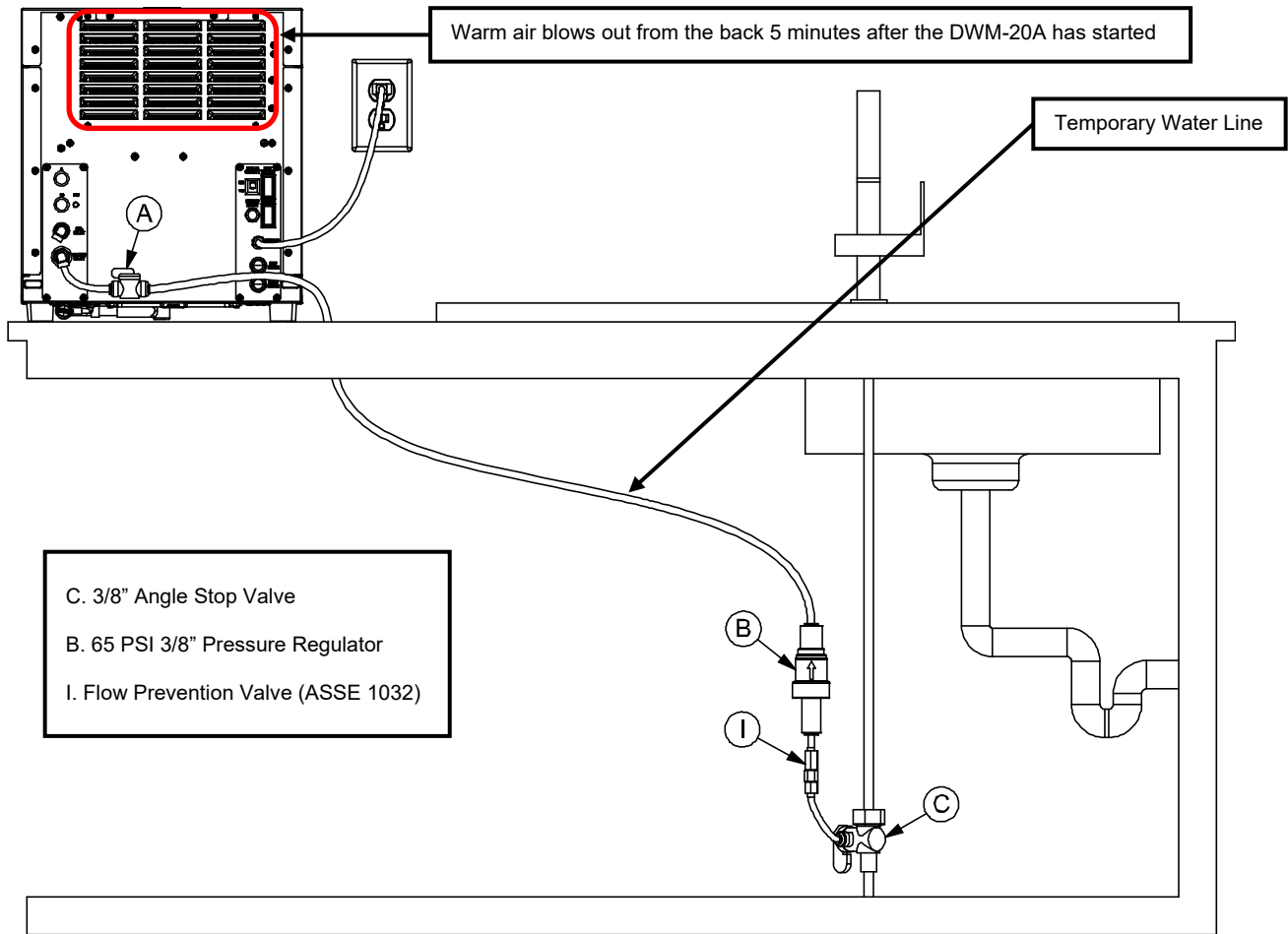

**BACK VIEW**

- Prepare a temporary water line to connect the water dispenser (DWM-20A unit):

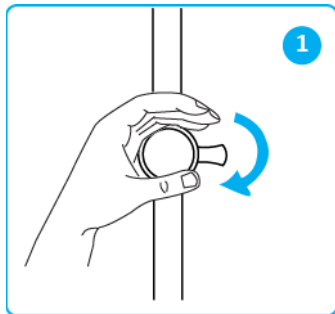

1. Locate and close the main valve for COLD water under the sink (turn it right completely), (fig 1).



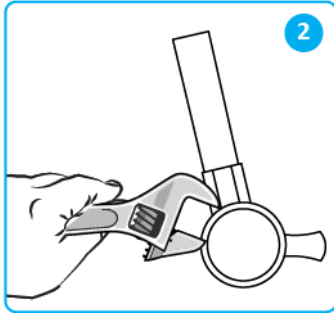

2. Using a pipe wrench, loosen the nut and disconnect the water line at the main valve, (fig 2).

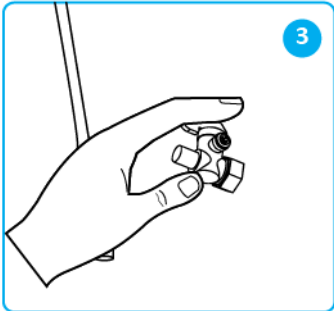

3. Next, install the “Angle Stop Valve” (C), as shown, (fig 3).

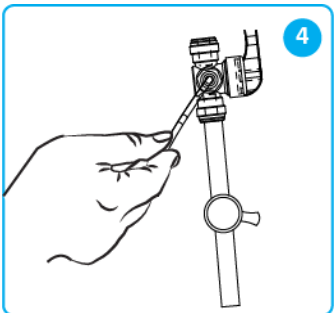

4. Locate the 3/8” flexible tube in the installation kit. Cut a short tube section to connect the angle stop valve to the other components of the installation kit, (fig 4). Then install the “ASSE 1032” backflow prevention valve (I), the water pressure regulator (B) and the shutoff valve (A).  
 ※Install (C), (I) and (B) close to each other. Install (A) close to the DWM-20A on the countertop. Make sure (C) is installed on the cold water source under the sink, NOT the hot water source which is often located next to the cold! Insert the other extremity of the 3/8” tube in the elbow quick-connector in the “WATER INLET” port located at the back of the DWM-20A. **IMPORTANT:** open both valves (C) and (A) so that water from the temporary water line can enter the DWM-20A.

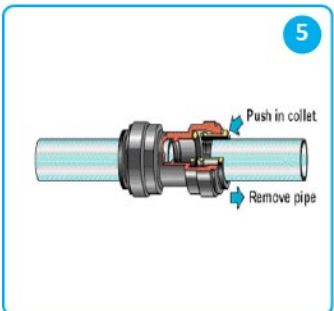

5. TIP: To connect the 3/8” flexible plastic tube to the other components of the installation kit, simply push the tube into the quick-connect fitting until it stops. Then pull out the tube to check if it is secured in its position and it is properly connected. To disconnect it, first push in the collet as shown in the fig 5. Next, with the collet held in position, remove the tube by pulling it away from the collet as shown.

**WARNING:** AS DIRECTED IN THE INTERNATIONAL PLUMBING CODE OF THE INTERNATIONAL CODE COUNCIL AND THE FOOD CODE MANUAL OF THE FOOD AND DRUG ADMINISTRATION (FDA), THIS DISPENSER MUST BE INSTALLED WITH ADEQUATE BACKFLOW PREVENTION TO COMPLY WITH FEDERAL, STATE AND LOCAL CODES. FOR MODELS INSTALLED OUTSIDE THE U.S.A., YOU MUST COMPLY WITH THE APPLICABLE PLUMBING/SANITATION CODE IN YOUR AREA.

- Locate the gas tubing (1/4") as found in the installation kit.
- Attach a CO<sub>2</sub> regulator (as provided in the installation kit) to the external CO<sub>2</sub> canister (not provided) by turning the nut to the right while holding the regulator. **IMPORTANT:** Ensure that the main valve on the external CO<sub>2</sub> canister is completely closed.
- Connect the CO<sub>2</sub> regulator using the 1/4" CO<sub>2</sub> tube, to the elbow quick connector (1/4") in the "CO<sub>2</sub> INLET" at the back of the DWM-20A appliance.
- Open the main valve on the external CO<sub>2</sub> canister very gently to avoid fast release of gas.
- Then, use the CO<sub>2</sub> regulator (see installation kit) to adjust the pressure. Turn the blue handle knob located on the front side of the CO<sub>2</sub> regulator. Set the pressure to your desired fizziness level (typically around 55 to 65 psi). After the pressure is set, push the blue knob in, to lock the arrow right at the selected gas pressure.
- See Figure 6 below. For fine tuning go on page 29.

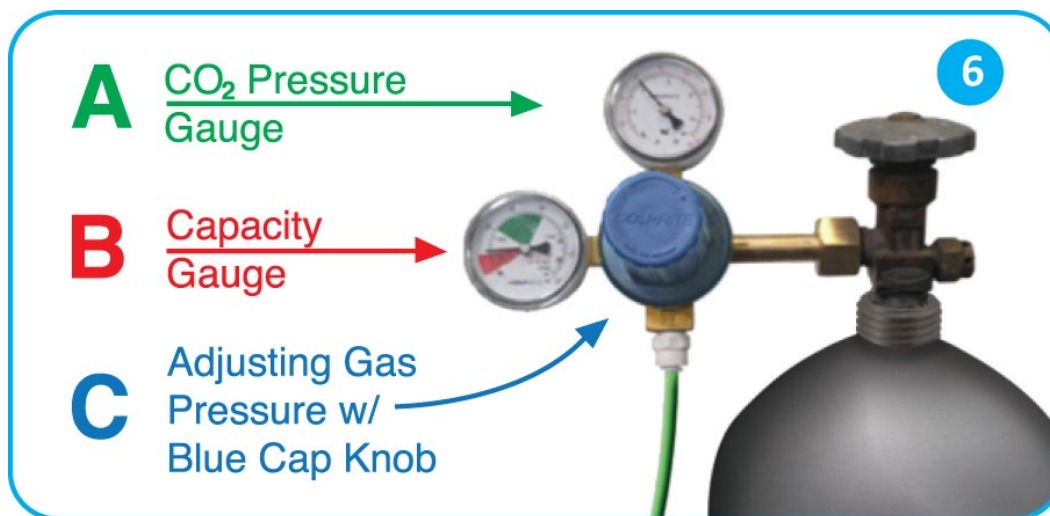

**WARNING:** THE CO<sub>2</sub> TANK MUST BE SECURED WITH A CHAIN OR RESTRAINT (P) IN AN UPRIGHT POSITION AS INDICATED ON PAGE 14 OF THIS MANUAL.

- At this point, locate the main electrical power socket and the main electrical power supply switch at the back of the DWM-20A, plug in the dispenser and switch the main electrical power ON (see fig 7 and fig 8 below). **IMPORTANT:** do not turn on hot water power yet (the red switch behind the DWM-20A). **IMPORTANT:** if the DWM-20A was NOT transported upright, make sure the DWM-20A has sat still in its position for at least 2 hours before turning on main power. This is to ensure the refrigerant has had time to settle.

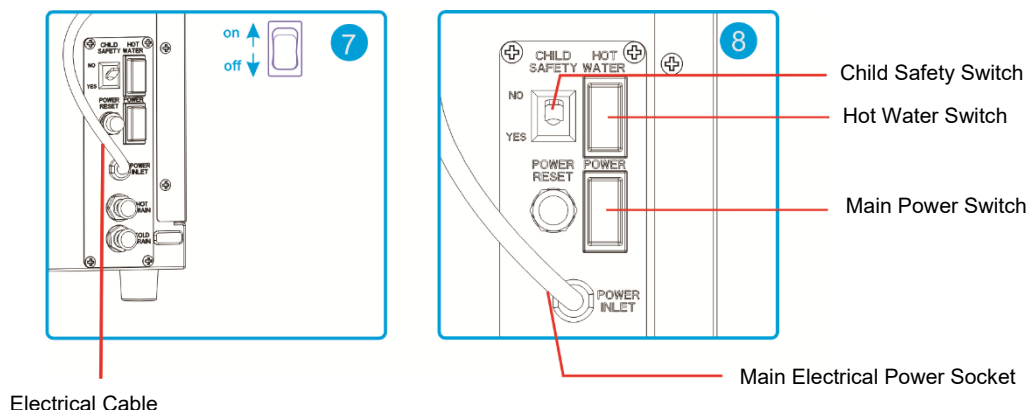

- With power on, after one (1) minute, two touch button lights - the green-sparkling and the white-alkaline - will start blinking. Touch and hold both of them – contemporarily – for three (3) seconds, until ALL all four button lights (green, blue, red, and white) will start blinking, indicating water is flowing into the dispenser.
- If valves (A) and (C) are both opened, the flow of water inside the DWM-20A will be audible, which indicates the automatic filling of the refrigeration system has been activated. This automatic filling process of the internal chiller of the unit may take up to ten (10) minutes. Wait. **IMPORTANT:** When the water dispenser is ready, all the touch button lights will stop blinking and stay illuminated.
- The unit's compressor starts after another five (5) minutes. Check the air temperature behind the dispenser's grid. The air blowing through the grid should be warm (red circle area in the picture on page 16).
- Touch the Alkaline button (white) and dispense alkaline water. Initially, the alkaline water may be gray in color because of the granular activated carbon contained in the alkaline chamber. After completely flushing the alkaline chamber HS-5442, the alkaline water dispensed is clear and transparent.
- Touch and hold the red-hot touch button until water comes out from the hot water nozzle (located just behind the main nozzle). Please note that the nozzle for the hot water is separated from the nozzle of alkaline, chilled and sparkling water in order to minimize splashes and to reduce flow rate (for safety reasons). If by touching the red button hot water is not dispensed, it is probably due to the Child Safety Switch located at the back of the dispenser being switched on (i.e. the switch is positioned on its "YES" position). The Child Safety Switch will prevent children from accidentally dispensing hot water by pressing the red button. Therefore, disabling the Child Safety Switch will allow you to dispense hot water by touching the red button. This will also activate the red-light indicator "HOT WATER" located at the right corner of the front of the dispenser. When the red light is illuminated - WARNING sign - the DWM-20A is enabled to dispense hot water. In order to dispense hot water, first the internal HOT WATER TANK MUST BE FILLED UP: touch the red button until the hot water tank is totally filled and water starts flowing out of the nozzle.
- Next turn on the hot water switch (red switch) located behind the DWM-20A model (see fig 8). It takes almost ten (10) minutes for the water in the internal hot water tank to reach the maximum temperature.
- Now dispense some Chilled and Sparkling (even without adjusting the CO<sub>2</sub> gas for optimal carbonation level), and check if the dispenser is working properly. **IMPORTANT:** for fine tuning of the dispenser, wait until the installation is completed and the water is very cold. If the water is not cold enough, carbonation will not occur!
- At this time, while the dispenser has started and its refrigeration and heating systems are working, you might need to drill a 3/4" hole on the countertop in proximity of the back of dispenser to connect the DWM-20A unit with its filtration system and its CO<sub>2</sub> tank. Use a one-piece hole saw or equivalent tool.
- At this point, close the Angle Stop Valve (C), and dispense some alkaline water for 5 seconds in order to release the water pressure inside the temporary water line.
- Shut off the valve (A) behind the Water dispenser but KEEP the electrical power on. Now you can remove the temporary water line.
- Leave the water dispenser powered on so that its refrigeration system can work during the time the filtration system is installed. Then, when the installation is completed, you can easily check the temperature of the chilled water and the carbonation of the sparkling water. **IMPORTANT:** Do not move the water dispenser since its refrigeration system is now full of water and might overflow. If you need to slightly move the DWM-20A to its final position, pay extreme attention. The dispenser is quite heavy now (93lbs), its refrigeration is full of water and any sudden movement might produce an internal water overflow and small flooding on the countertop. Avoid this. Do not ever incline the DWM-20A.
- Install the leak detector tee (D) close to the water pressure regulator (B). Do not activate leak detector by inserting its alkaline battery until the installation is complete.
- Connect (D) & (F) (i.e. the 3/8" 2-way divider), which is the inlet of the two All-in-One filters HS-5441. The two filters shall be connected "in parallel". Connect the temporary line from the other 3/8" 2-way divider (the outlet port of the double All-in-One filters) directly to the sink to allow flushing of the filters. Open the angle stop valve (C) and keep it open until clear water is dispensed through this temporary line. **IMPORTANT:** the complete flushing of the external filters may require up to five (5) gallon of water to pass through.

- When completely clear water is dispensed through the double All-in-One filters, close the angle stop valve (C) again, and remove the temporary water line.

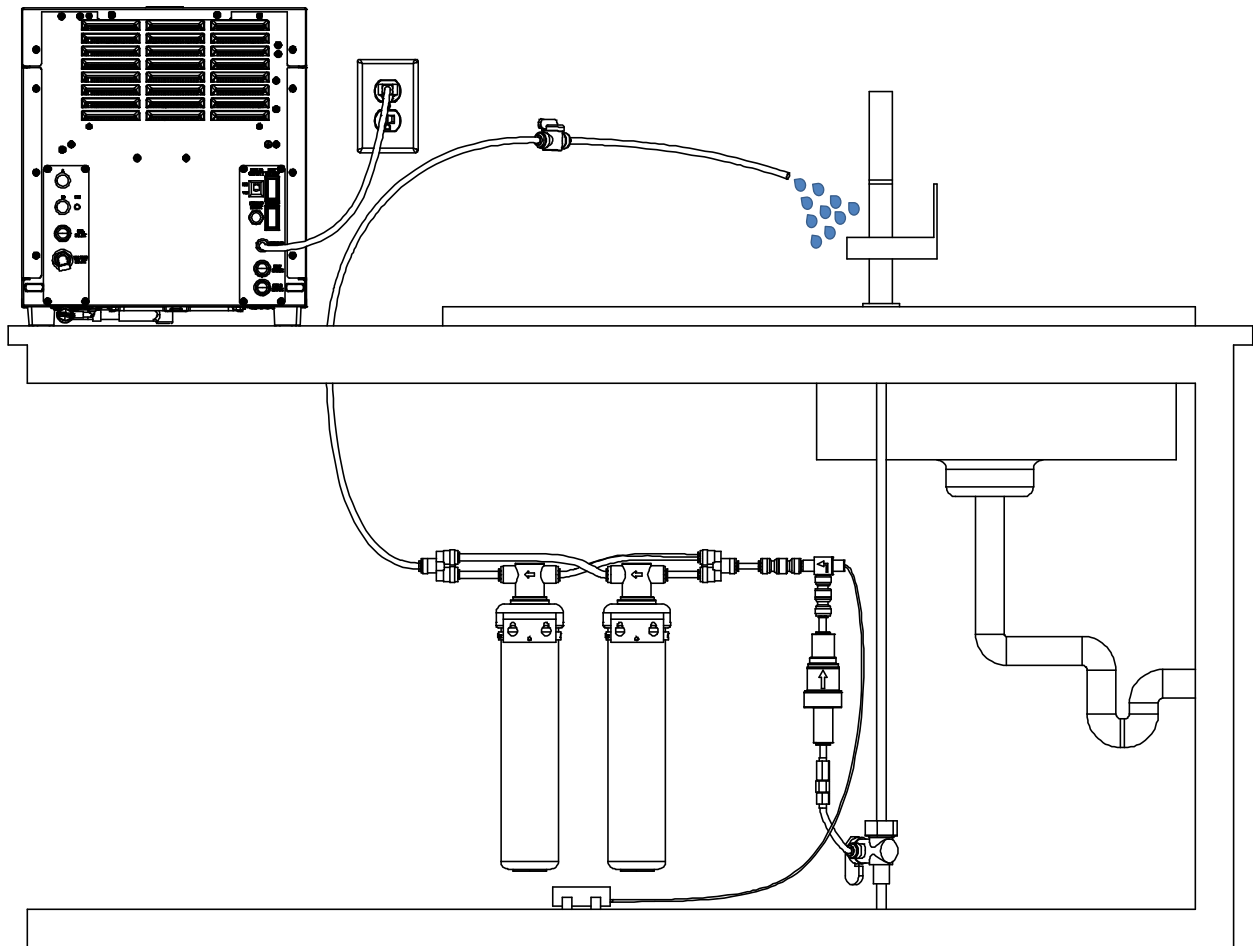

**BACK VIEW**

- Run a line from the back of the dispenser to the 3/8" 2-way divider which is connected to the filters' outlet port.
- Now that the entire water line is connected, as per the picture on the next page, open the angle stop valve (C) and also the shutoff valve (A).
- **IMPORTANT:** make sure DWM-20A is fully connected to the water line and to the CO<sub>2</sub> line and dispense some water from DWM-20A. Now pull all the lines: the 3/8" water inlet line, the 1/4" CO<sub>2</sub> gas line and, also, the 1/2" water drain line, if present) in order to check if they are all properly connected with the various John Guest connectors. Make sure there are no leaks. Insert collect locking clips 1/4" and 3/8" as appropriate at any junction.
- Insert the battery (included) into the water leak detector. Use a small piece of wet fabric or wet paper towel in order to test the leak detector by using the wet fabric or paper towel to touch both electrodes and close the circuit. Check that the leak detector gets triggered correctly by listening for a loud beep. To reset the leak detector, press and hold its reset button for five (5) seconds until the water solenoid valve of the leak detector opens.
- Make sure that the entire installation area is clean and dry. Cut a small square of (completely dry) paper towel, fold it and position the paper towel under the electrodes of the leak detector: if the paper towel gets wet due to a flooding, the leak detector will activate and the solenoid valve will close the water line. Then the leak detector will

start beeping loudly. However, thanks to the paper towel wrapped around, a small spill from a glass of water or from the drain pan would not be sufficient to trigger the leak detector.

- Carefully position the leak detector under the counter, close to the double All-in-One filters, or in an area where potential flooded water would naturally accumulate, (see diagram below).

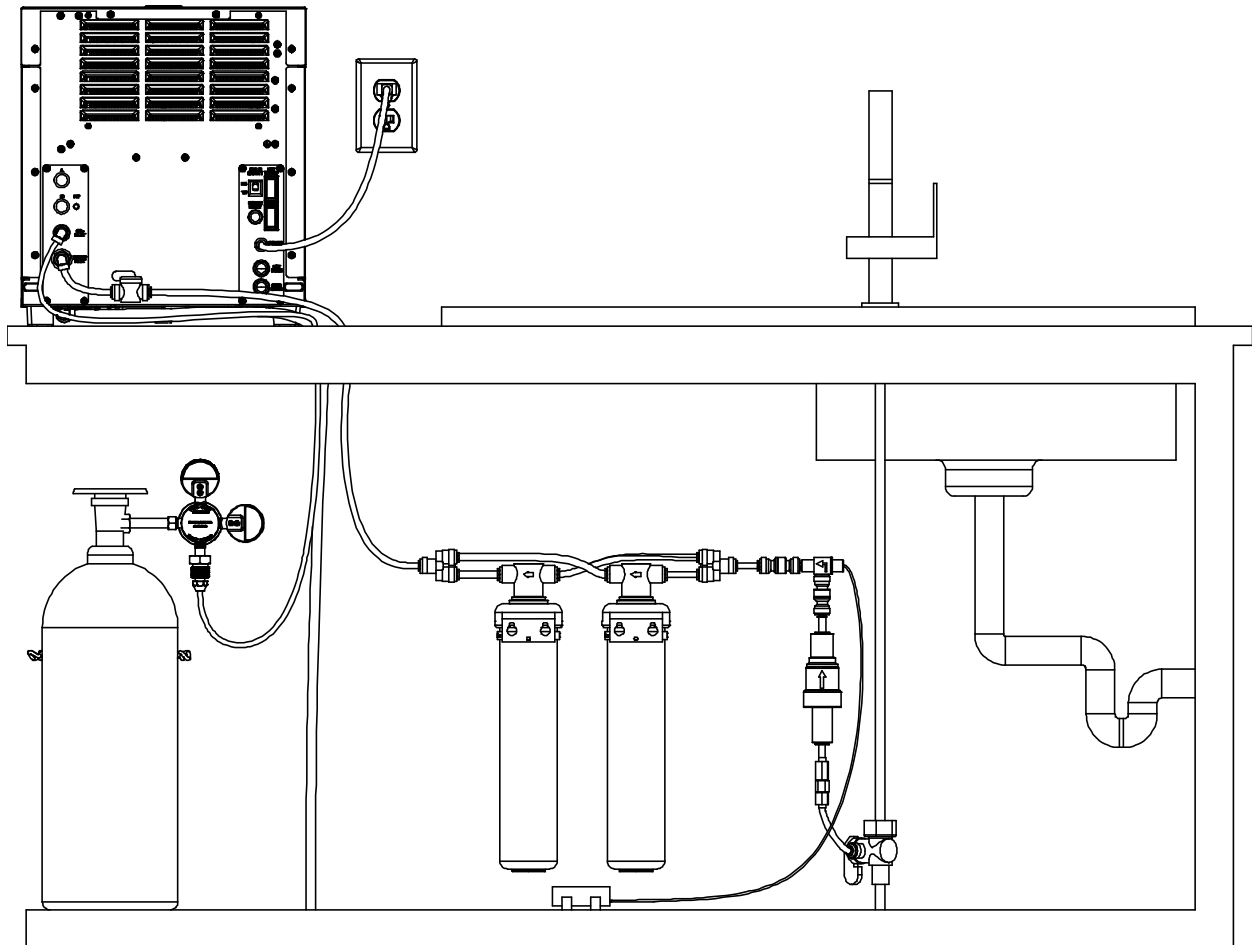

**BACK VIEW**

- Now the installation is complete, and it is time for setup and fine tuning. Place a bottle or container on the drain pan. Dispense alkaline water (white button) until the dispensed water is clear of carbon particles. **NOTE:** It is normal that the first two gallon of mineralized alkaline water appears black or milky in color. Wait 10 minutes. Dispense two gallons more until the water is completely clear. Repeat the process after waiting another 10 minutes until the alkaline water is totally transparent.
- Dispense 16 oz. of chilled (still) water (blue button). If the DWM-20A has been turned on for more than one hour, the chilled water now should be ice-cold.
- Next, dispense 16 oz. of sparkling water (green button). Make sure the regulator has the arrow in the green region (see fig 6 on page 18). For fine tuning of the carbonation level, refer to the table on page 29.
- Next, dispense hot water (red button). Check if the red LED light top left is on. If the hot water tank heater has been on for more than 10 minutes, the hot water now should be boiling-hot.

- If you have installed the DWM-20A filtration correctly, the green light indicator “FILTER” (top right) should also be solid green at this point.

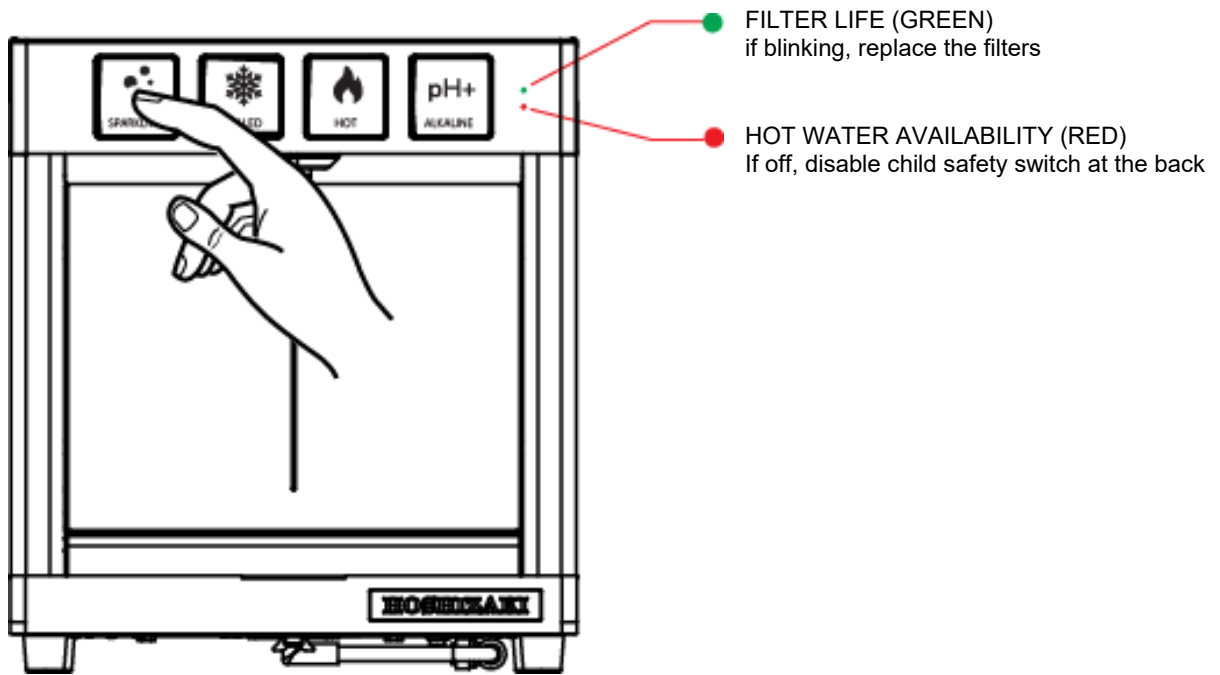

## Installation on AM-50/C-80 Ice Makers

The MODwater DMW-20A can also be mounted on Hoshizaki AM-50 or C-80 undercounter ice makers. The base of the DWM-20A is designed to perfectly fit on top of these ice makers and can be secured by using two mounting brackets, provided separately as an accessory. The overall installation process follows the same steps as above, but there is no need to drill holes in countertops.

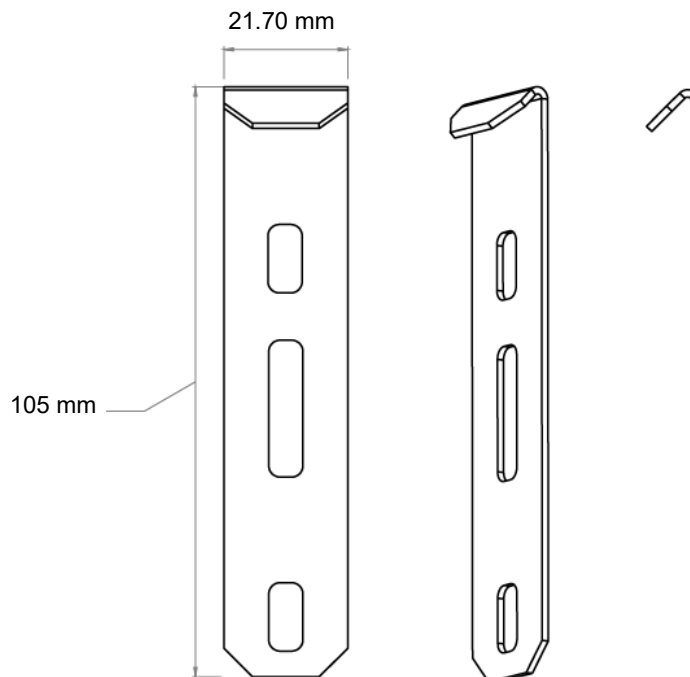
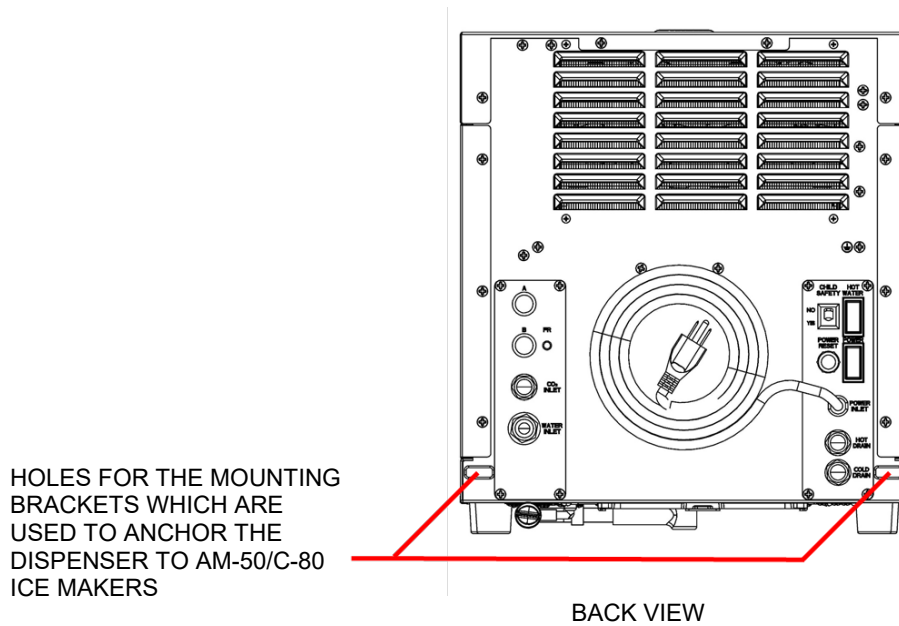

Mounting Brackets (2pcs) 4A0363-01  
(Not included, order separately)

**NOTE:** The DWM-20A cannot be mounted on the cabinet door models (- DS version) of the AM-50/C-80 models

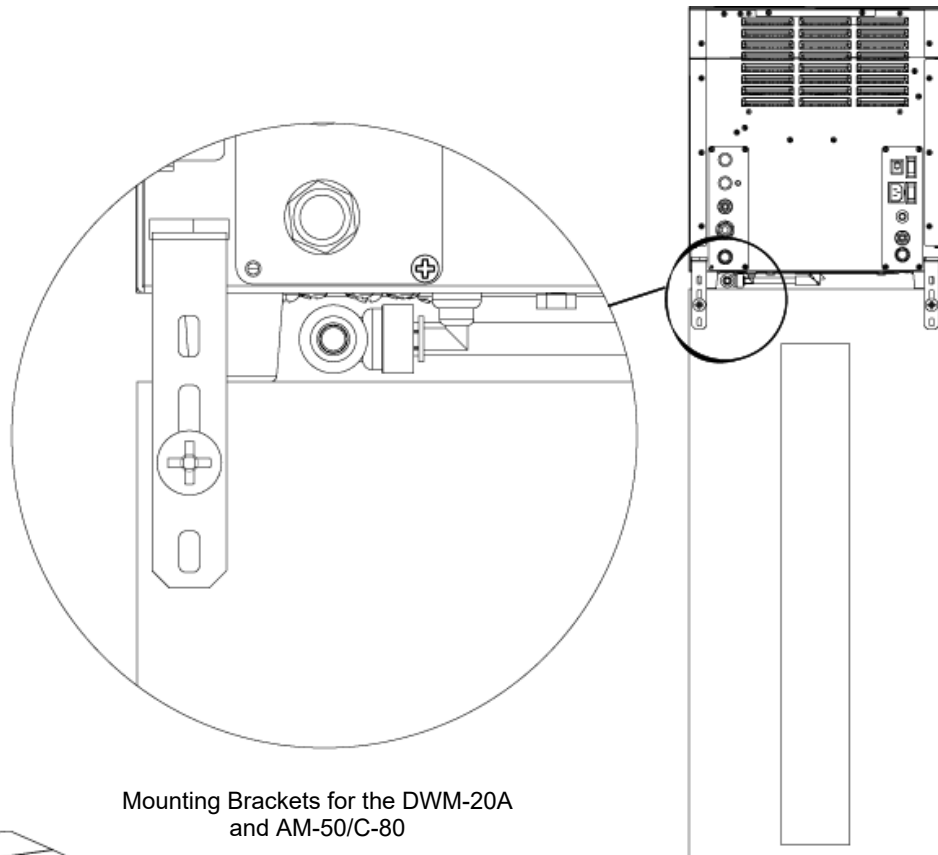

Mounting Brackets for the DWM-20A  
and AM-50/C-80

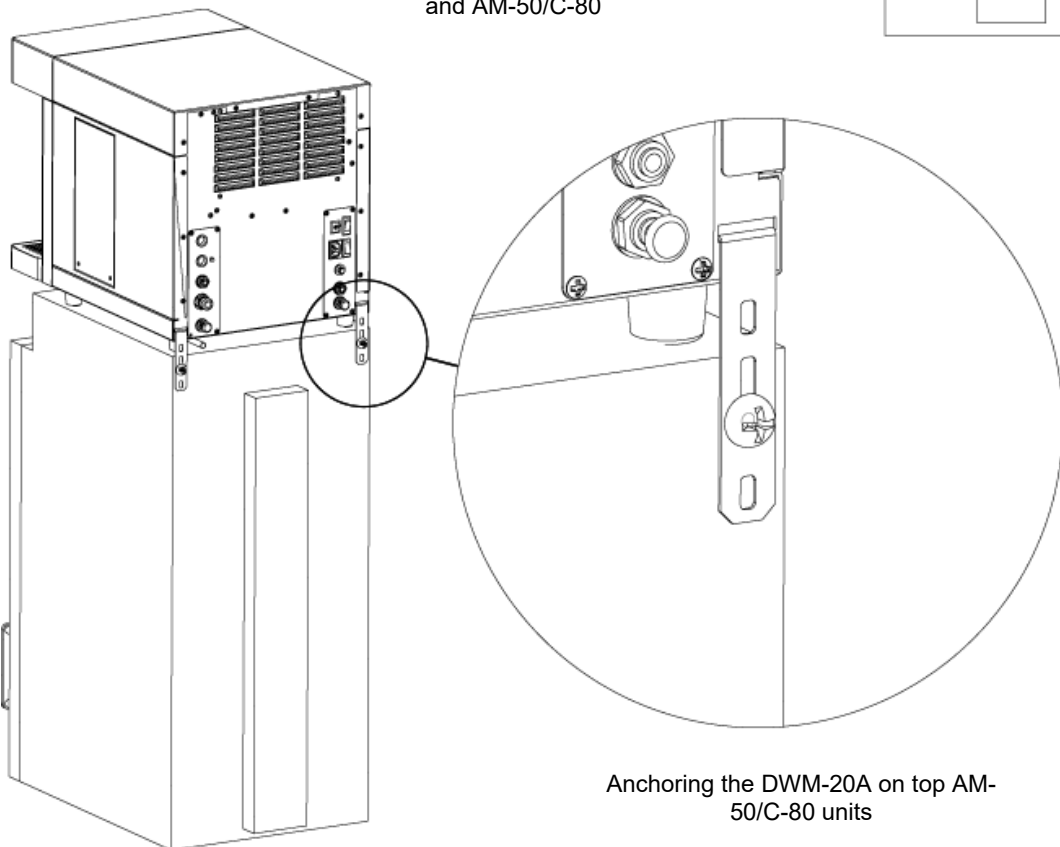

Anchoring the DWM-20A on top AM-  
50/C-80 units



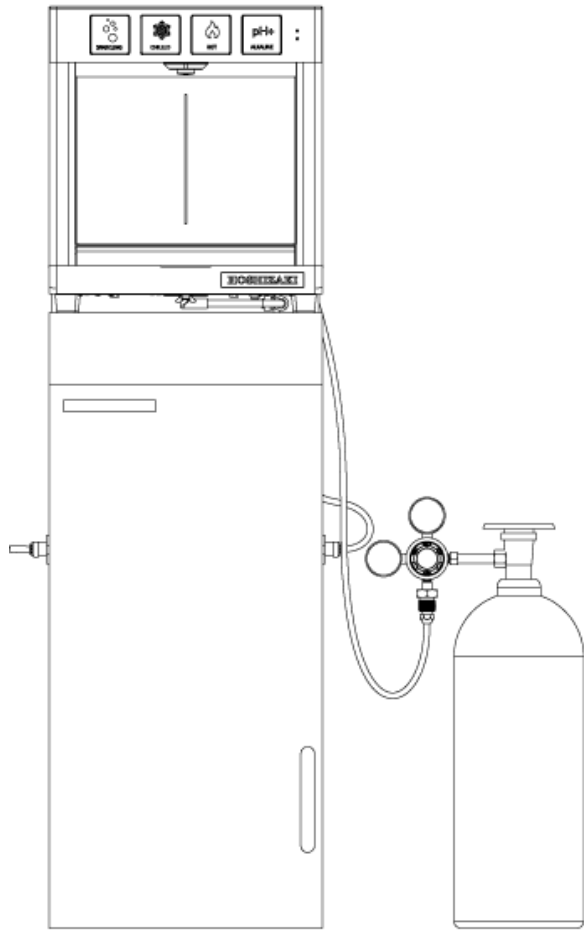

FRONT

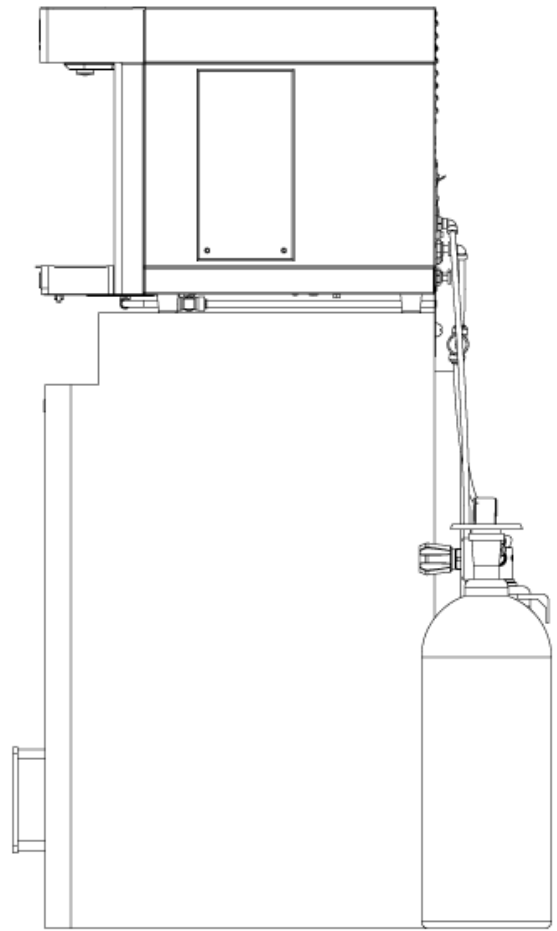

SIDE

Completed Installation of DWM-20A on AM-50/C-80

**WARNING:** The CO<sub>2</sub> tank must be secured to the wall with a metal chain or restraint (not included, order separately)

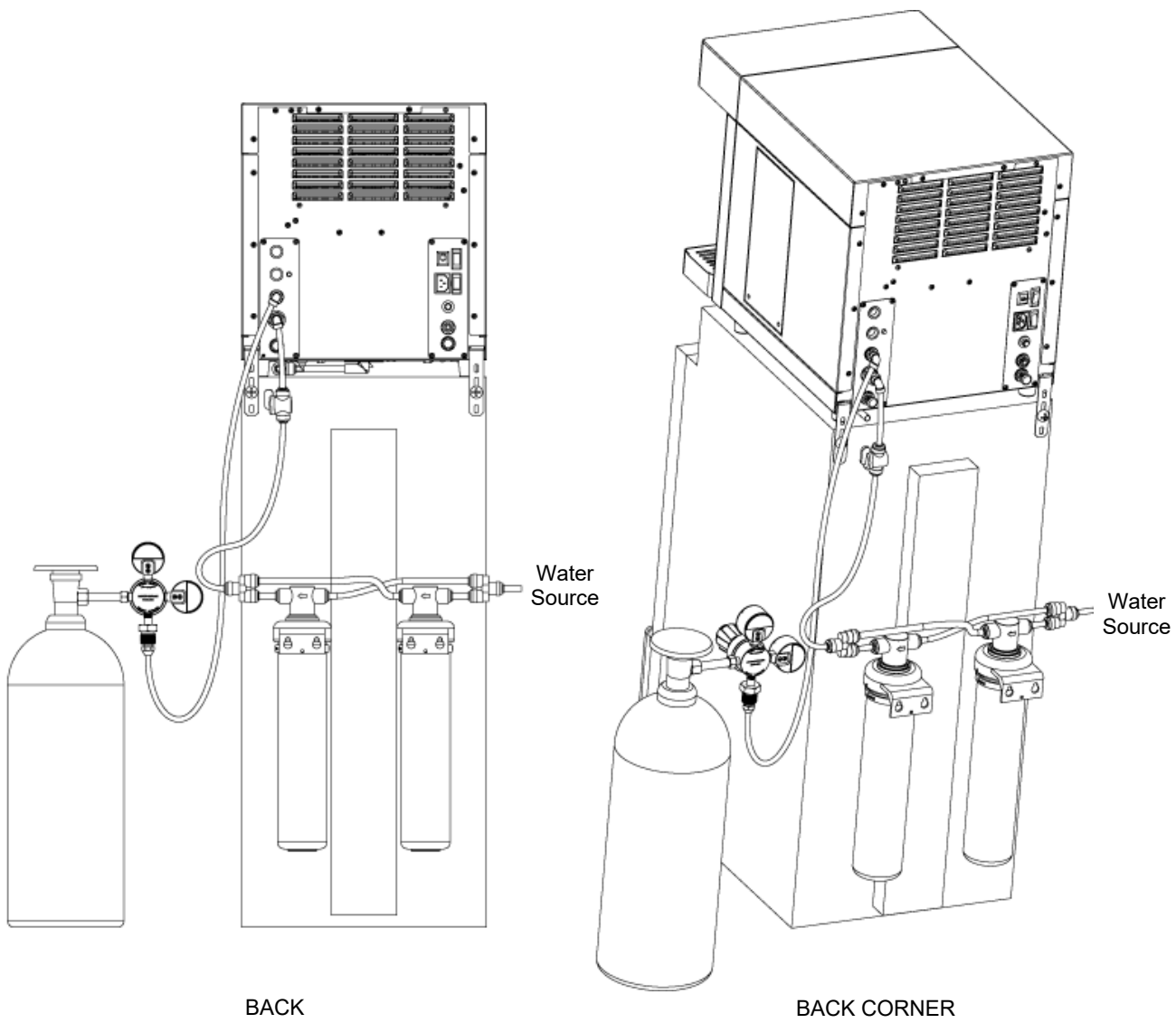

Completed Installation of DWM-20A on AM-50/C-80

MAX 20 lbs

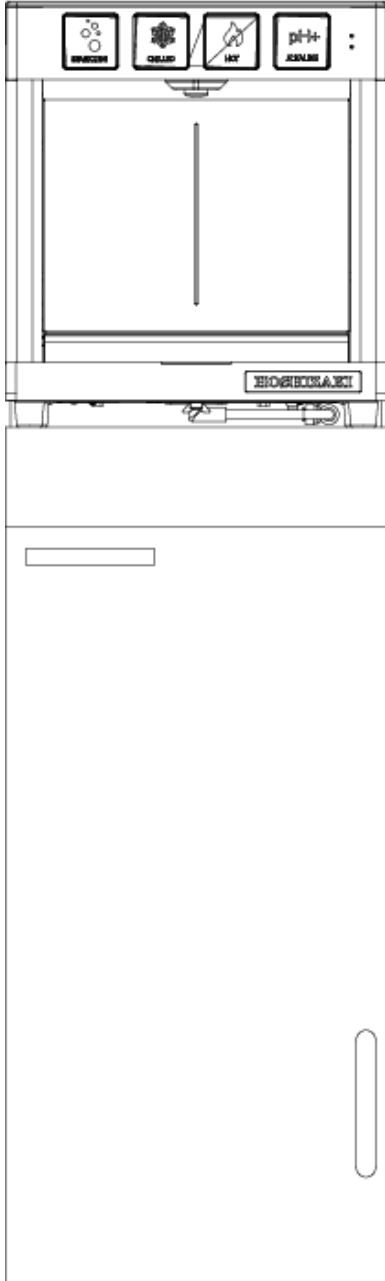

**WARNING:** MAX LOAD WEIGHT ON TOP OF DWM-20A = 20 LBS

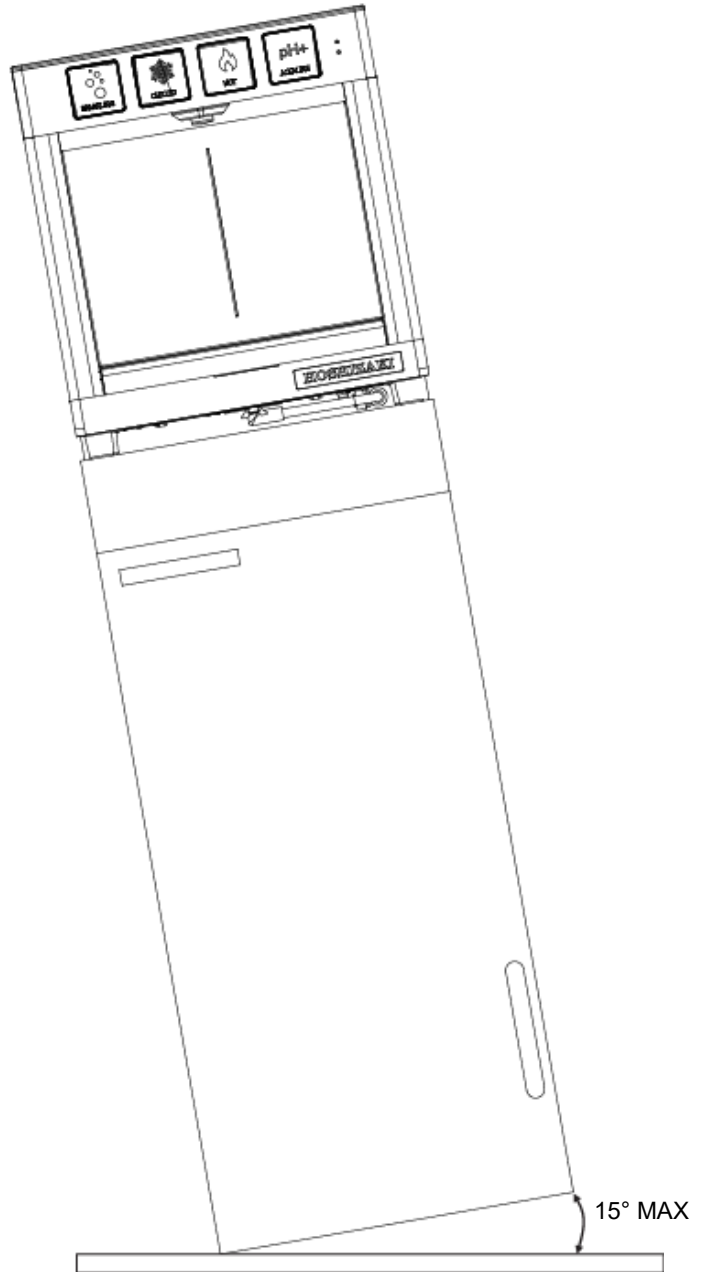

MAX TILT = 15 DEGREES

**WARNING:** DO NOT TILT

# OPERATION

## Alkaline Water

Touch and hold the white button to dispense alkaline water (fig 9).

## Chilled Still Water

Touch and hold the blue button to dispense chilled water (fig 10).

## Chilled Sparkling Water

Touch and hold the green button to dispense chilled sparkling water (fig 11). Increase the bubble level to desired fizziness level as described in the following page.

## Hot Water

Touch and hold red button to dispense hot water (fig 12).

The red LED light indicator labeled “HOT WATER” at the right corner on the touch panel indicates that the DWM-20A is ready to dispense hot water. If the red light indicator is off, the dispenser will not dispense hot water because the child safety is inserted (“YES”). To turn on the hot water dispensing function, simply turn off the “Child Safety Switch” located on the back of the dispenser (move it to its disabled position: up, where the word “NO” is indicated), and be sure to turn on the red Hot Water switch on the back of the unit as well, in order to switch the hot water tank heater on.

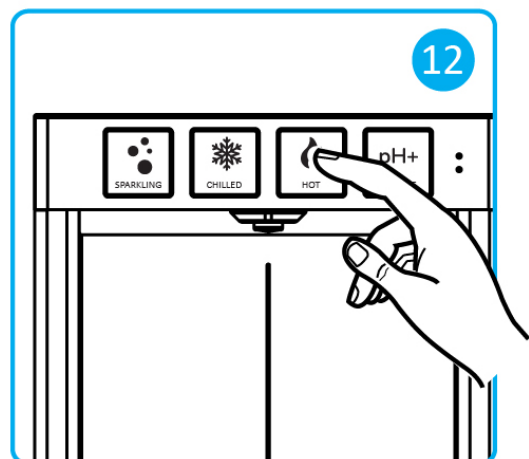
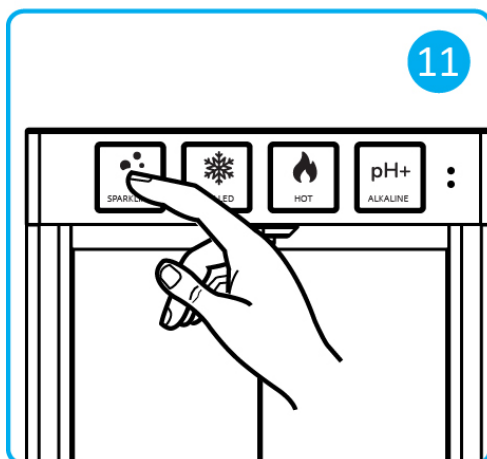
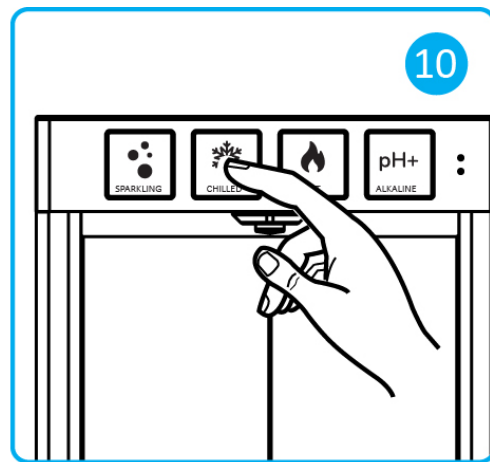
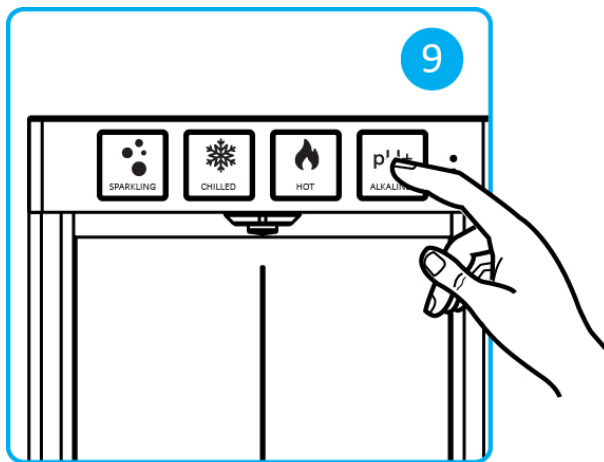

TIP: For precise adjustment of carbonation level, measure the inlet water pressure entering DWM-20A and follow this table below:

Inlet Water Pressure	CO <sub>2</sub> Pressure
45 psi	45-50 psi
50 psi	50-55 psi
55 psi	55 psi
60 psi	60 psi
65 psi	65 psi

# MAINTENANCE

## Empty Drain Pan

If the drain pan is NOT connected to its drain line, it must be regularly emptied:

- Gently pull the drain pan with care to avoid spilling.
- Empty the water inside and clean the drain pan with soapy water if necessary.
- Put the drain pan back in place.

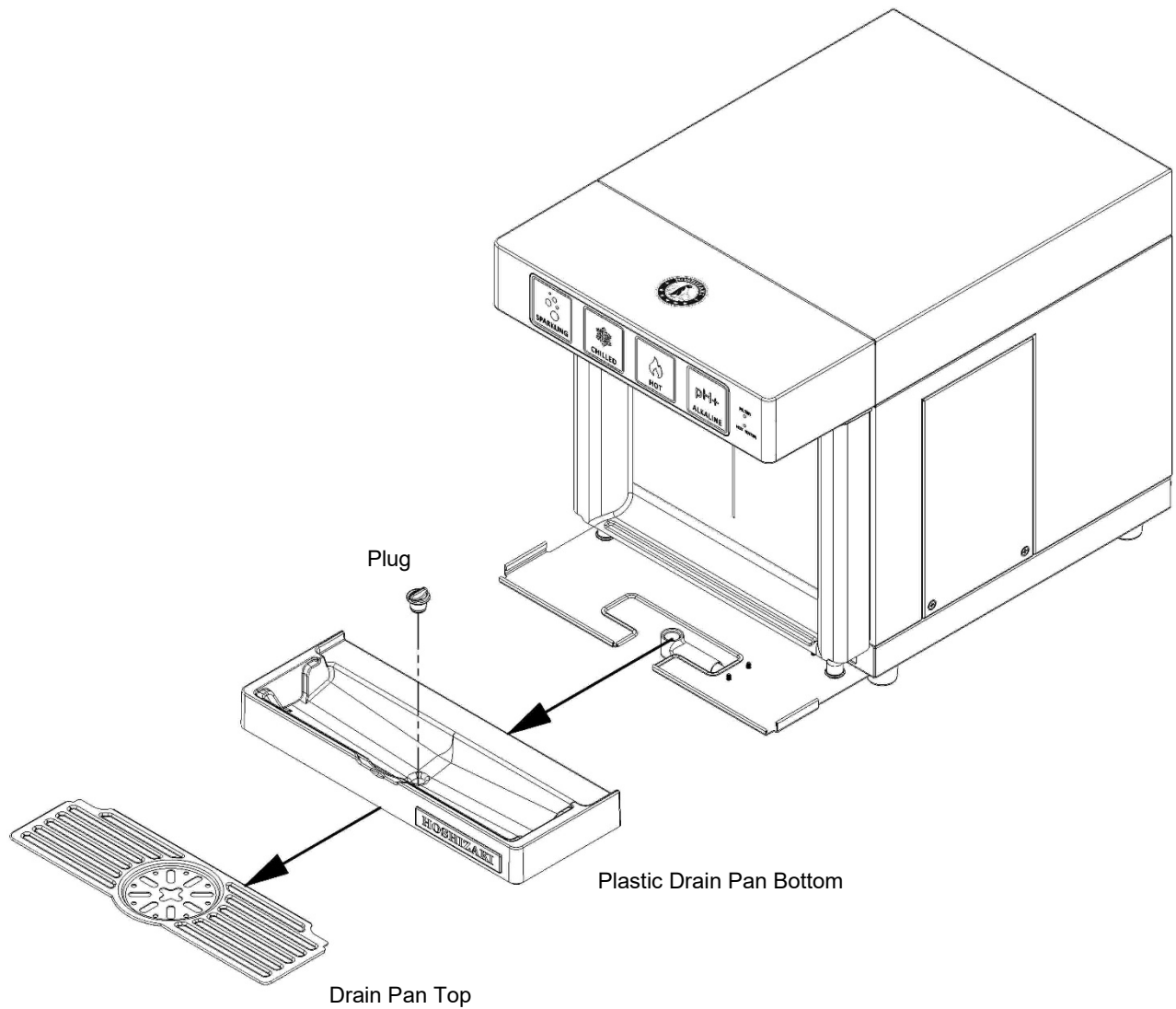

## CO<sub>2</sub> Tank Replacement

If the arrow on the “Capacity Gauge” is in the red region, it is time to replace the CO<sub>2</sub> tank. Follow these steps below:

1. Fully close the main valve on top of the CO<sub>2</sub> tank.
2. Release gas pressure by touching the green button on the water dispenser and dispensing sparkling water, or by pulling the gas valve (see fig 6 on page 18).
3. Shut the the CO<sub>2</sub> regulator, turning the knob counter-clockwise until the arrow on the “Gas Pressure Gauge” is close to zero.
4. Using a wrench, remove the regulator from the empty tank.
5. Screw the CO<sub>2</sub> regulator to the new (full) tank.
6. Open the main valve on top of the tank completely.
7. Open the CO<sub>2</sub> valve (clockwise) on the regulator knob.
8. Reset the gas pressure to the desired level (i.e. the arrow must be in the green region).

## Cleaning and Sanitation

### WARNING

SANITARY GLOVES ARE TO BE USED DURING CLEANING OPERATIONS. APPLICABLE SAFETY PRECAUTIONS MUST BE OBSERVED. INSTRUCTION WARNINGS ON THE PRODUCT MUST BE FOLLOWED.

CLEANING SOLUTIONS CONTAIN ACIDS. THESE COMPOUNDS MAY CAUSE BURNS. IF SWALLOWED, DO NOT INDUCE VOMITING. CALL PHYSICIAN IMMEDIATELY. IN THE CASE OF EXTERNAL CONTACT, FLUSH WITH WATER. KEEP OUT OF REACH OF CHILDREN.

The DWM-20A is constructed with high quality stainless steel. Cleaning with a glass cleaner and a soft cotton cloth will keep the stainless steel of the DWM-20A clean. Using sparkling water to clean external surfaces is also an option.

## Surface Finish Care

Do not use cleaners containing chloride, chlorine bleach solutions, concentrated soaps, water with high salinity, or hydrochloric acid, since they will cause corrosion or discoloration of the stainless-steel surface.

Do not use metal scrapers, sharp objects, steel wool, scouring pads, or abrasives on the unit.

Do not use a water jet to clean the surface.

Highly concentrated cleaners may cause aesthetic damage to plastic and metal finishes.

## Areas of Maintenance

Routine sanitization of the DWM-20A dispenser should be performed on the following parts:

- 1) Nozzle
- 2) Nozzle Guard
- 3) Front Plate Dispensing Area
- 4) Drain Pan Top
- 5) Drain Pan Bottom

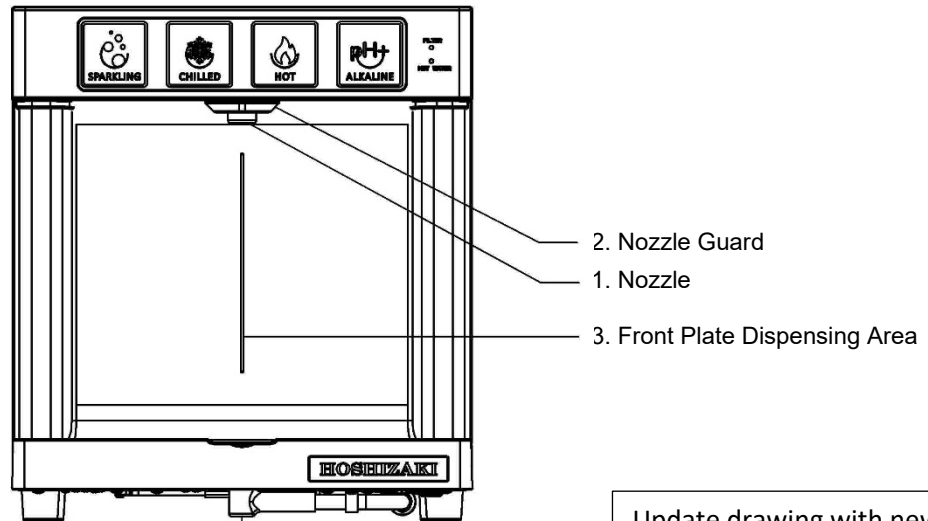

Update drawing with new design of drain pan top

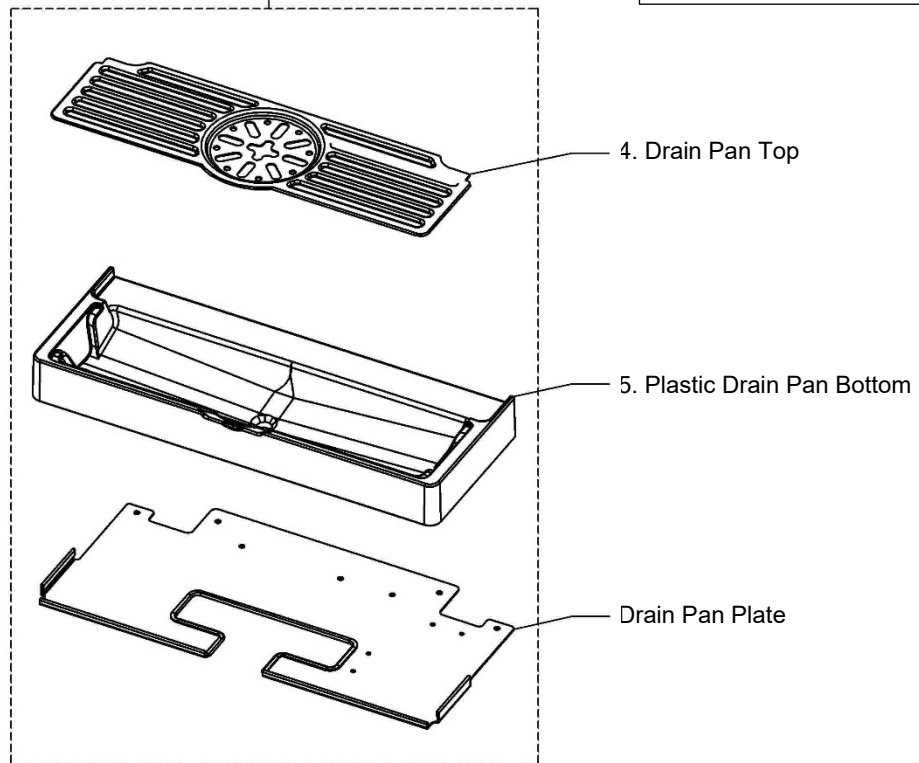



## Daily

Keep exterior surfaces of the dispenser (nozzle, nozzle guard, front plate dispensing area, drain pan top, drain pan bottom) clean by using a clean, damp cloth. While wearing sanitary gloves, sanitize the exterior surfaces with a hydrogen peroxide (3% solution) and allow the surface to air dry. When cleaning and sanitizing the touch buttons, be sure to power off the dispenser to prevent accidentally dispensing water. Additionally, it is important to keep the drain pan clean of debris. Remove any as soon as it is noticed.



Example: Hydrogen Peroxide (3% Solution) Spray

## Weekly

Use a vacuum to clean out dust from all the vents.

Pour hot water into the drain pan to keep the drain open (if the drain pan is connected to a drain line).

## Every Six Months

**NOTICE:** These operations must be carried out by an authorized technician and should be done every time the All-in-One filters and alkaline chamber are replaced.

### 1) Replacing the Nozzle Tip:

- A. Disconnect the power so that water is not accidentally dispensed.
- B. While wearing sanitary gloves, remove the nozzle cap by unscrewing it counterclockwise. Remove the aerator and o-ring from the nozzle cap. A special tool is available from Hoshizaki.
- C. Insert new aerator and o-ring (both available as service parts from Hoshizaki) into the nozzle cap and screw the assembly back into the nozzle.

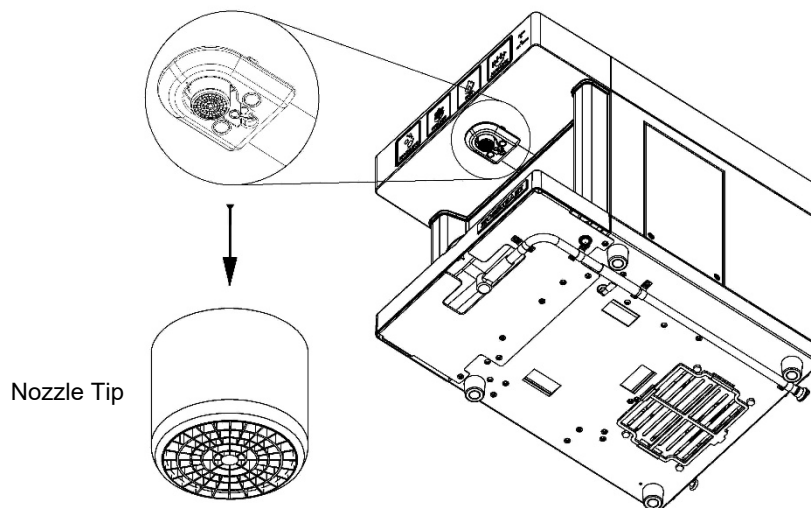

## 2) Replacing the Air Filter

- A. The air filter is located underneath the dispenser. While wearing sanitary gloves, slide the air filter out of the dispenser.
- B. Slide in a new air filter into the dispenser.

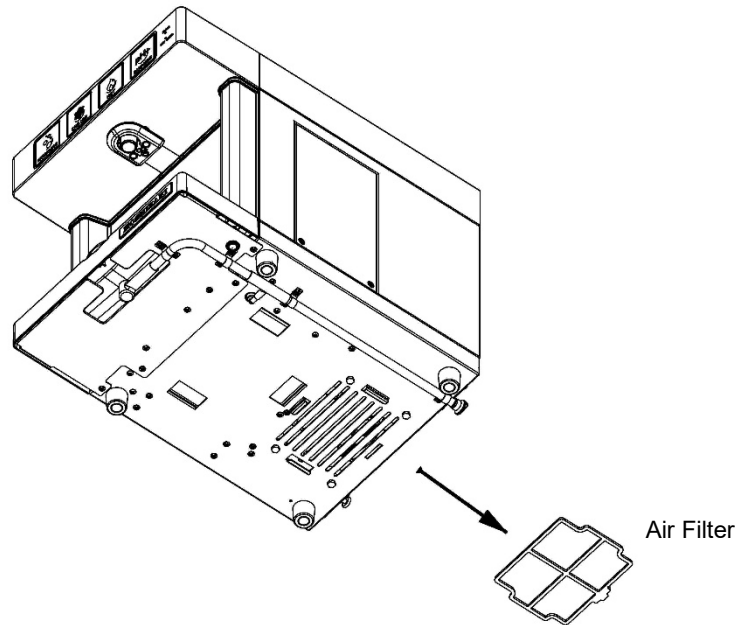

## 3) Replacing the 2 external All-in-One filters (HS-5441) and the internal alkaline chamber (HS-5442)

Replace the two external All-in-One filters (HS-5441) and the alkaline chamber (HS-5442) when the filter life green LED indicator blinks (i.e. it means that 6,000 gallons have been dispensed by the DWM-20A dispenser) or every 6 months, whichever comes first. Instructions are also found on the label of the All-in-One filter (HS-5441) and on the label of the alkaline chamber (HS-5442). Follow this procedure step-by-step:

- A. Locate the main water shutoff valve (the angle stop valve).
- B. Shut off the water line valve (i.e. the angle stop valve) and relieve the water line pressure by selectively touching the dispensing buttons until no more water comes out from the dispenser.
- C. Locate the two All-in-One filters HS-5441.
- D. Hold the head of each filter firmly. Rotate the cartridge clockwise,  $\frac{1}{4}$  turn, and pull it out.
- E. Insert a replacement cartridge by rotating it counter-clockwise,  $\frac{1}{4}$  turn, until it clicks and stops. The arrow on the top collar should align with the arrow on the head.
- F. Get a bucket or sink to flush filters: remove the water line from the back of the dispenser and re-open the water supply so that the HS-5441 filters can be flushed out in a 5 gal. bucket or in the sink. Flush the filters for 5 minutes or until the water runs clear. DO NOT flush the filters through the dispenser.
- G. When the two new HS-5441 filters have been flushed, shutoff the main water valve (angle stop valve) again and locate the alkaline chamber HS-5442 inside the side panel door on the right side of the dispenser.
- H. Unscrew and remove the panel to reveal the alkaline chamber.

- I. Rotate the alkaline chamber clockwise, 1/4 turn, and pull it out.
- J. Insert a new alkaline chamber by rotating it counter-clockwise, 1/4 turn, until it clicks and stops. The arrow head on the top collar should align with the arrow on the head.
- K. Re-insert the water line into the "WATER IN" port on the back of the dispenser and re-open the main water line valve.
- L. Now flush the alkaline chamber by dispensing approximately 2 gallons of alkaline water using the alkaline touch button. When the alkaline water comes out clear, the dispenser is ready.
- M. At this point, before closing the side panel door, it is wise to check for leaks from the All-in-One filters HS-5441 and the alkaline chamber HS-5442. Make sure they are sealed correctly. Push the filter reset ("FR") button at the back of the dispenser for 10 seconds in order to reset the volumetric count of water consumption.

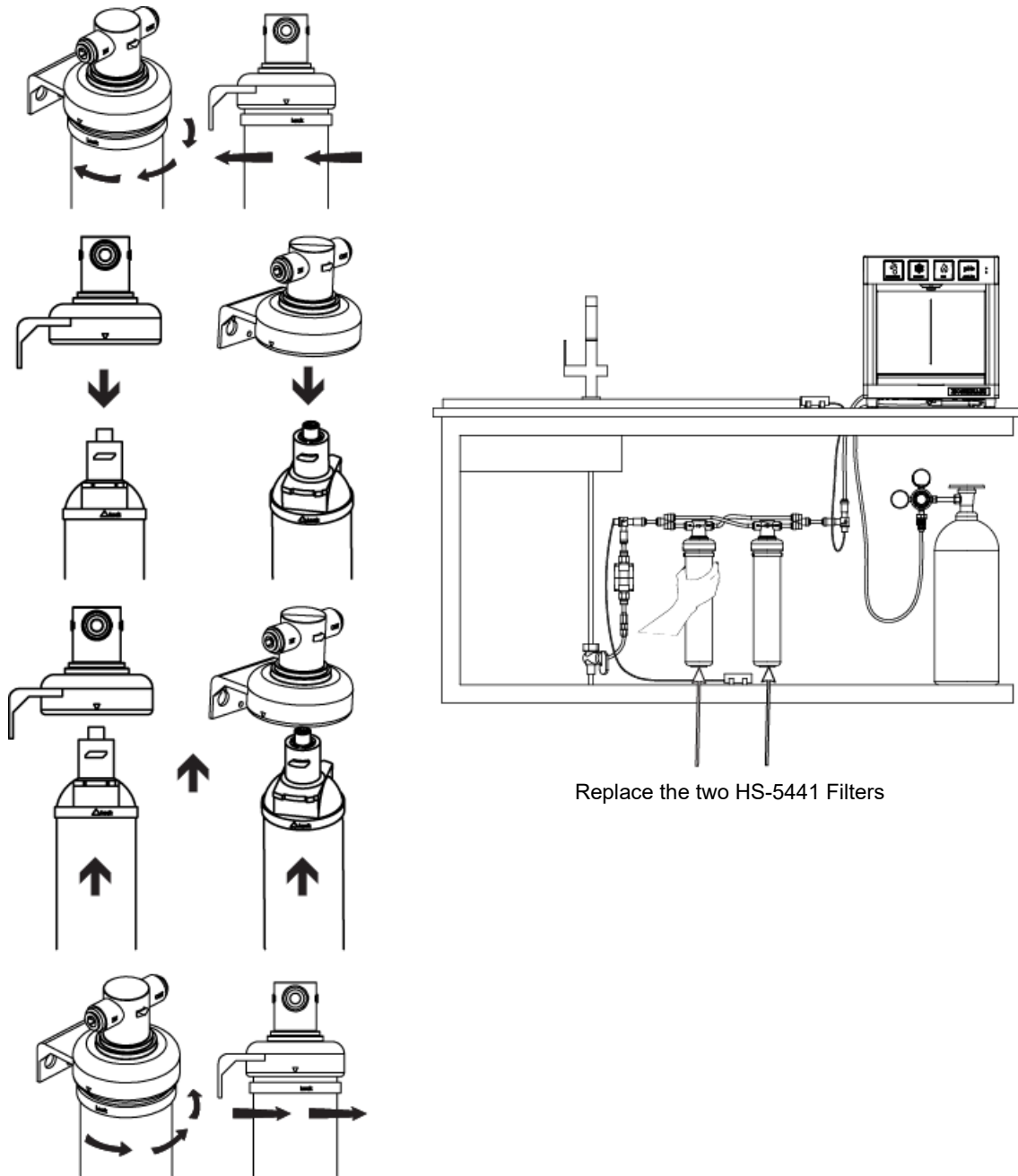

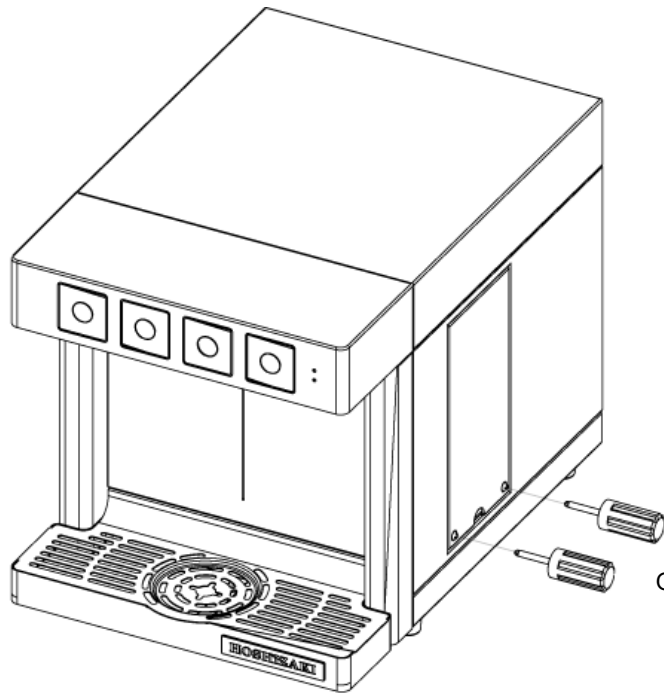

Open the Side Panel Door

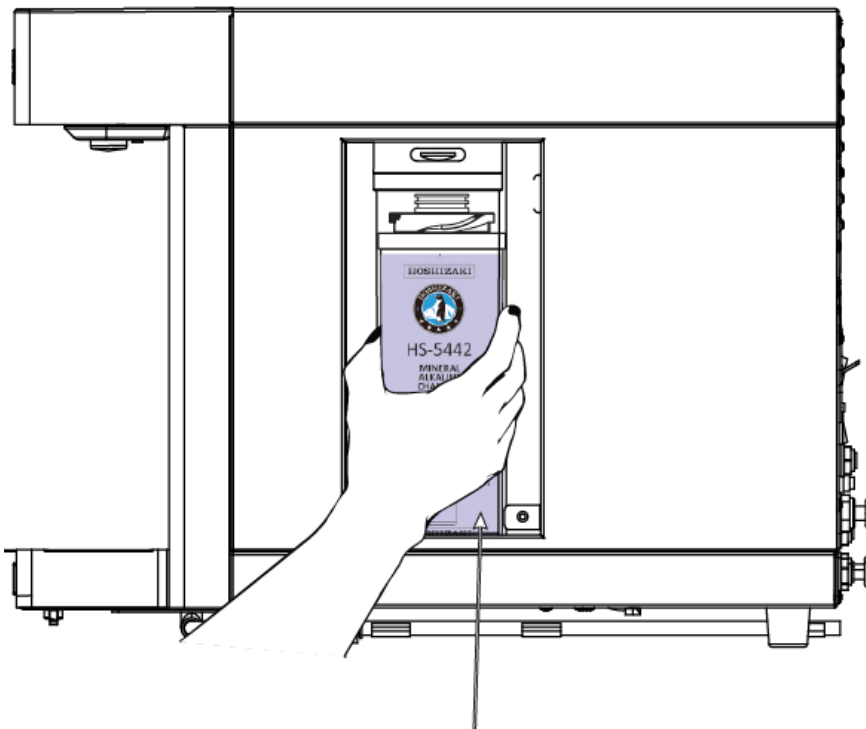

Replace the alkaline chamber HS-5442

## Changing the Alkaline Chamber

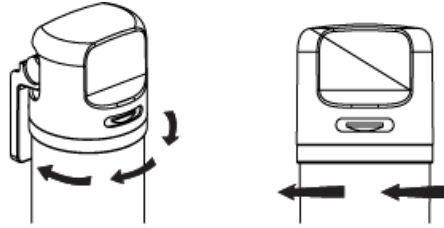

1. Shut off water and relieve line pressure.
2. Hold head firmly. Rotate the old cartridge clockwise 1/4 turn and pull it out.

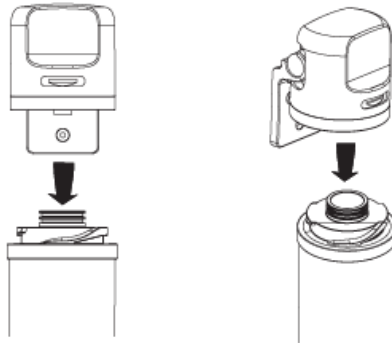

3. Pull cartridge down and out of the head.

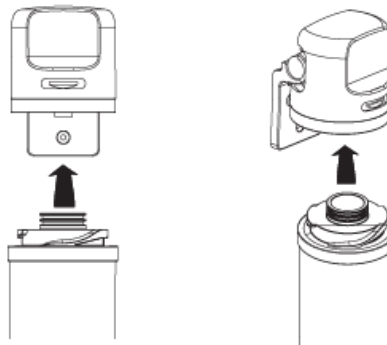

4. Hold head firmly. Insert new cartridge into the filter head.

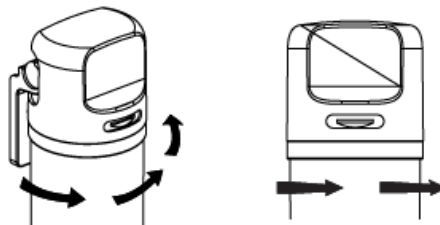

5. Turn the new cartridge into the filter head and rotate counter-clockwise 1/4 until rotation clicks and stops.
6. Flush filter for 5 minutes before use or until water runs clear, by touching the (white) Alkaline button.

## 4) Cleaning and Sanitizing the Hot Water Tank

**NOTICE:** This operation must be carried out by an authorized technician. This operation takes one hour.

You must follow the guidelines and procedures for the cleaning and sanitizing solution established by the manufacturer.

### **WARNING**

**WATER TO DRAIN MAY BE EXTREMELY HOT (190°F).** Do not turn off the hot water switch on the back of the dispenser. Before starting, confirm that the water line is properly connected.

1. Empty the hot water tank by using the drain line.
2. Prepare and add 950 ml of cleaning solution from the drain line into the hot water tank by using the hot water tank inflow system (order separately). To check if the hot water tank is full of solution, dispense hot water until you see solution coming out of the nozzle.
3. Leave the cleaning solution inside for 5 minutes.
4. Press the hot water button and dispense at least 2 gallons.
5. Empty all the liquid from the hot water tank by using the drain line.
6. Prepare the sanitizing solution (order separately). Dilute the sanitizing solution with water at 10-15%. Use the same hot water tank inflow system to fill the hot tank.
7. Leave the sanitizing solution inside the Hot Water Tank for 20 to 30 minutes.
8. Begin dispensing liquid from the hot water line. You must dispense at least 2 gallons.
9. Repeat step 6, 7 and 8 above for a second time.
10. Empty all the sanitizing solution from the hot water tank by using the drain line.
11. Begin dispensing water from the hot water line. This will fill the Hot water Tank with water. Empty the hot tank from the drain line and repeat this process twice to ensure that all the sanitizing solution is out.

## Electrical System

The DWM-20A dispenser must be plugged directly into 110/120 VAC, 60Hz wall outlet only (15 Amps). A 15A – 125VAC / 250VAC circuit breaker is installed on the dispenser and the circuit breaker can be accessed for reset at the back of the dispenser (i.e. Power Reset Button).

**IMPORTANT:** In case of breaker trip, only reset once. If it happens again shortly after, send the water dispenser back to the Manufacturer for maintenance.

## Transporting and Relocating

If the DWM-20A dispenser needs to be relocated to another place or sent back to the manufacturer or the dealer for repairs, it is necessary that the water inside the hot water tank and the refrigeration system is drained. Please follow the below procedures:

1. Close the CO2 supply line by turning the handle knob (turn clockwise) on the CO2 tank's regulator.
2. Dispense sparkling water (green button) to make sure that sparkling water comes out totally flat (no gas).
3. Close the water supply line and turn the shut-off valve located right behind the dispenser to the "off" position.
4. Dispense alkaline water (white button) until no more water is dispensed from the dispenser.  
**NOTE:** DO NOT dispense chilled water (blue button).
5. Turn the Main Power switch to its "off" position. The main power switch is located on the back of the dispenser. Leave the dispenser disconnected for 24 hours to defrost its refrigeration system.
6. After 24h or more, proceed with de-installation. Unplug the power cord from the back of the dispenser.
7. Unplug the CO2 tube (1/4" tube) on the back of the dispenser.
8. Unplug the "WATER INLET" tube (3/8" tube) on the back of the dispenser.
9. Locate the "Cold Drain" and "Hot Drain" on the back of the dispenser. Remove the plug from the "Cold Drain" to drain the water from the dispenser's refrigeration system and drain into a bucket or container. These will be about 2 gallons of water. **IMPORTANT:** Use a five-gallon minimum container to collect the water drained from the dispenser.
10. Next, repeat the process for "Hot Drain". **WARNING:** Water from "Hot Drain" may still be hot, even after 24 hours.
11. Put the plugs back into the "Cold Drain" and "Hot Drain". The DWM-20A dispenser is now ready to be transported. Package the dispenser carefully, as its stainless steel external surfaces might be easily damaged during transportation.
12. In case of swap-out between two DWM-20A, remember to also change both the filters (HS-5441), and the alkaline chamber (HS-5442).

**For help during de-installation, call our toll-free service number at 1 (800) 233-1940.**



# TECHNICAL SUPPORT

## Troubleshooting

<p>A. Lights are off</p>	<p>Check that the dispenser is NOT in its <b>“SLEEP MODE”</b>. If the green dot light indicator (top right of the front plate) is illuminated, the dispenser is simply “sleeping”. Touch any button for a few seconds to start it and all buttons will illuminate. If ALL lights are off (including the two LED indicators at the top right of the touch panel), check the main power cord connection: if plugged in, check main power switch. If the dispenser is connected to a power source, and if the main power switch is on, press the power reset button once or twice. The power reset button is located at the back of the dispenser, just below the main power switch and is indicated with the letters “PR” (i.e. <u>P</u>ower <u>R</u>eset).</p>
<p>B. Both the green &amp; red LED indicators are blinking, while all four (4) touch buttons are off and no water can be dispensed</p>	<p>The DWM-20A has entered <b>“SAFETY MODE”</b>. There is no water in the supply tubing or the water pressure is too low. Or somebody has operated the unit dispensing more than 1.5 liters without pausing, or for more than 30 seconds without pausing. If the issue is no water, make sure water supply valve is open or, to address low water pressure, replace filters or use booster pump to increase water pressure. Once the issue is solved, turn off the unit and after three seconds turn it on again. If the issue is solved, the unit will restart normally.</p> <p>If it persists call 1 (800) 233-1940 for help.</p>
<p>C. There is an audible beeping sound</p>	<p>A leak detector is activated. In that case, proceed as per instructions (see page 43) and reset the leak detector to work.</p>
<p>D. Sparkling &amp; Alkaline touch buttons are blinking</p>	<p>Indicates that the refrigeration system must be filled up. Touch and hold both buttons contemporarily for three seconds until ALL the buttons are blinking. Wait until all buttons stop blinking and are solid. Now the dispenser should be able to operate. Make sure there is water in your pipeline flowing to the dispenser. If not, check your water line; perhaps you need to open the shutoff valve located at the back of the dispenser or the main shutoff valve at your location.</p>
<p>E. All four (4) touch button lights are blinking</p>	<p>Indicates that the refrigeration system is being filled with water. You should be able to hear it. If not, check the water line; perhaps you need to open the shutoff valve located at the back of the dispenser or the main water valve at your location. If there is water in your pipeline this operation lasts five (5) to ten (10) minutes.</p>

F. Does not dispense hot water at all	“Child Safety Switch” is on its “YES” position (i.e. down), indicating that child safety switch has been enabled. To allow hot water to be dispensed, turn the “Child Safety Switch” at the back of DWM-20A to its “NO” position (turn it up). The red LED dot indicator on the touch panel of DWM-20A should turn on.
G. Hot water is not hot	Check if the hot water power is on (red switch on the back). If not on, turn it on (up) and wait ten (10) minutes for the water to reach its maximum temperature.
H. Hot water touch button (red) is off. All other buttons are on.	The DWM-20A entered “ <b>ENERGY SAVING</b> ” and automatically disconnected the hot water tank because it was not used for an entire month. Push and hold the hot water button (red) for 15 seconds: the button’s red light will be on again and hot water will start coming out.
I. Does not dispense water at all, even when pushing the Alkaline option (white button)	There is no water in your pipeline, Check the main water supply connection and all the shutoff valves.
J. Sparkling water comes out flat, or no carbonated enough	Check the CO2 tank: the “Capacity Gage” might be in the red region. If it is in the red region, replace tank. Otherwise, if the tank is full, adjust pressure to necessary levels using CO2 regulator: arrow must be in between 50 and 65 psi. If gas pressure is high while water is dispensed totally flat, turn the knob on the gas regulator anticlockwise (i.e. close it). Then release pressure by cutting the gas tube (see fig 6 on page 18).
K. Green light indicator is blinking	The DWM-20A dispenser requires 2 new filters and a new alkaline chamber. Call 1 (800) 233-1940. After replacing the filters and the alkaline chamber, push and hold for 5 seconds the <u>F</u> ilter <u>R</u> eset button (indicated with the words “FR”) at the back of the DWM-20A, until the green LED indicator turns solid green back again.
L. None of the above	Switch the dispenser off (main power switch), as per Maintenance section of this Manual, page 42) and contact customer service for assistance. 1 (800) 233-1940.

## Leak Detector Troubleshooting

The installation kit for DWM-20A provides one (1) leak detector which will automatically shut off the water to the dispenser if leaks are detected (assuming that its electrodes are correctly positioned and its alkaline battery is charged).

However, very often leak detectors are activated by minor water spillage from the drain pan and/or a partially wet counter. In that case a beep is clearly audible and the leak detector must be reset.

See the table below for leak detector troubleshooting and instructions.

Problem	Action
Blue light continuously blinking & continuous audible beeping.	After the leakage problem is solved, press the light blue button for 5 seconds. The detector will emit a long beeping sound, then will resume operation.
Red light continuously blinking & continuous audible beeping.	Replace battery. To do so, remove the battery cover on the right side of the control unit and replace the 9V battery.

## Support

For any questions, please contact customer service for assistance at the toll-free number 1 (800) 233-1940.

## Recycling Program

Return the used DWM-20A to the manufacturer, whose address is listed on [www.hoshizakiamerica.com](http://www.hoshizakiamerica.com)

**Please visit our website  
www.hoshizakiamerica.com  
Or call our toll-free number at 1 (800) 233-1940**

# **WARRANTY CONDITIONS**

Three-Year Limited Warranty for DWM-20A dispenser to consumers. This Limited Warranty is only valid for the United States of America and its territories. For installations outside of the USA call 1 (800) 233-1940 to receive related Warranty.

The manufacturer warrants this dispenser against defects in material or workmanship for a period of three years, if this dispenser is purchased either directly from the manufacturer or from its authorized retailers or distributors. Under this Limited Warranty, the manufacturer will either, (i) repair the dispenser using new or refurbished parts or, (ii) replace this dispenser with a new or refurbished dispenser with the same or superior specifications or performance characteristics. For the purpose of this Limited Warranty, a “refurbished” dispenser or part is one that has been returned to its original specifications. In the event of a defect, the above is your exclusive remedy and the manufacturer’s only liability.

## **LIMITATIONS OF WARRANTY**

This Limited Warranty covers ONLY the dispenser. It DOES NOT cover its external filtration system, alkaline chamber, the CO2 tank used in connection with the dispenser, the CO2 regulator which is fixed to the tank, the parts constituting the “Installation Kit” as per the Instruction Manual, or any other consumables, accessories or components that might be packaged together with the DWM-20A dispenser. It DOES NOT cover software updates or modifications, whether or not contained in the box. No remedy is available under this warranty if you do not use DWM-20A original filtration system. You will have no remedy under this Limited Warranty in the event of any tampering with this dispenser. Connecting this unit with water sources or electrical power supply with characteristics or specifications other than those described in the Instruction Manual will automatically deprive you of any remedy under this Limited Warranty. Not using original parts, including HS-5441 filters and HS-5442 alkaline chamber, not replacing the cartridges (both HS-5441 and HS-5442) every six months or when filter life LED indicator starts blinking, whichever comes first, flushing external filters through this dispenser or using the dispenser in a way that is not intended voids this Warranty. This Warranty DOES NOT cover normal wear-and-tear to the dispenser or its components, or any damage due to negligent or improper use of the dispenser (please refer to the Manual). The Warranty is also void for damages or malfunctioning due to sub-standard installation of the dispenser performed by persons, other than authorized technicians. This Limited Warranty DOES NOT cover a dispenser sold AS IS and it DOES NOT cover technical assistance for the installation/usage of the dispenser on ships, boats or other means of transport.

## **OTHER LIMITATIONS**

This Limited Warranty only covers issues and malfunctions caused by defects in material or workmanship during ordinary and recommended/allowed use of this dispenser (see Manual). It does not cover issues caused by any other reason, including but not limited to acts of God, misuse (including, but not limited to, using this dispenser outside the specs indicated in the Instruction Manual), limitations of technology, or modification of or to any part of this dispenser. It does not cover any dispenser purchased from anyone other than the manufacturer or its authorized retailers or distributors. To determine if a retailer or distributor is authorized, please visit [www.hoshizakiamerica.com](http://www.hoshizakiamerica.com) or contact the Manufacturer’s customer service line. You will have no remedy under this Limited Warranty if the factory applied serial number has been altered or removed from the back of this dispenser or if the Manufacturer’s original warranty stickers on the back of the dispenser have been removed or cut and are not replaced. This Limited Warranty is not valid outside of the U.S.A. and its territories.

**INSTRUCTIONS**

To obtain warranty service, you must deliver this dispenser, freight prepaid, in either its original box, or packaged affording an equal degree of protection to the manufacturer: Hoshizaki America, Inc. at the address specified on the manufacturer's website [www.hoshizakiamerica.com](http://www.hoshizakiamerica.com) and available by contacting the manufacturer at 1 (800) 233-1940. A dated purchase receipt from the manufacturer or its authorized retailer or distributor is also required.

**WARRANTY ON REPAIR/REPLACEMENT**

This Limited Warranty shall apply to any repair, replacement part or replacement dispenser only for the remainder of the term of the Limited Warranty on the original dispenser, or ninety (90) days from the customer's receipt of the repaired/replacement part or dispenser, whichever is longer. Any parts or dispenser replaced under this Limited Warranty will become property of the manufacturer.

**WARNING**

DO NOT REMOVE THE COVER OR THE BACK OF THIS DISPENSER: THERE ARE NO SERVICEABLE PARTS INSIDE! DOING SO MIGHT RESULT IN ELECTRIC SHOCK OR OTHER INJURIES AND WILL AUTOMATICALLY DEPRIVE YOU OF ANY REMEDY UNDER THIS WARRANTY.

**WARRANTY DISCLAIMER**

THIS WARRANTY IS IN LIEU OF ANY OTHER IMPLIED OR EXPRESS WARRANTIES.

**LIMITATION OF LIABILITY**

THE MANUFACTURER SHALL UNDER NO CIRCUMSTANCES BE LIABLE FOR ANY INCIDENTAL OR CONSEQUENTIAL DAMAGES, WHETHER FOR BREACH OF WARRANTY OR OTHER CONTRACT BREACH, NEGLIGENCE OR OTHER TORT, OR ON ANY STRICT LIABILITY THEORY. Some states do not allow the exclusion or limitation of incidental or consequential damages, so the above exclusion may not apply to you. This warranty gives you specific legal rights, and you may also have other rights which vary from state to state.