



HOSHIZAKI

Parts List

Modular Flaker

Models

F-2001MWH

F-2001MRH(3)(-C)

F-2001MLH



hoshizakiamerica.com

Number: 71354
Issued: 7-11-2014
Revised: 3-28-2018

CONTENTS

Note About Ordering Parts	3
A. Main Assembly & Refrigeration Circuit	4
F-2001MWH	4
F-2001MRH(3)(-C).....	7
F-2001MLH.....	10
B. Ice Making Unit.....	13
C. Water Circuit.....	15
D. Control Box Assembly.....	17
E. Accessories & Labels	19

Auxiliary Codes

F-2001MWH	D-0	July 2014
	E-0	January 2015
	F-0	January 2016
	G-0	March 2017
	G-1	April 2017
F-2001MRH	D-0	April 2014
	E-0	January 2015
	F-0	March 2016
	G-0	January 2017
	G-1	August 2017
F-2001MRH3	D-0	May 2014
	E-0	February 2015
	F-0	January 2016
	G-1	April 2017
F-2001MRH-C	D-0	April 2014
	E-0	January 2015
	F-0	April 2016
	G-1	April 2017
	H-0	February
F-2001MLH	D-0	July 2004
	E-0	January 2015
	F-0	July 2016
	G-1	April 2017

Auxiliary Code Breakdown

The auxiliary code is the first two characters in the serial number. The first character indicates the year. Years progress or regress in alphabetical order. The series runs from "A" through "V" and the letters "I" and "O" are skipped. The second character indicates significant part changes within a year. Base is "0" and this number advances for each change. In cases where there is a letter in parentheses, this designates the month. This is the last character in the serial number. The series runs from "(A)" through "(M)" and the letter "(I)" is skipped. This designation is only included when identifying a parts change within an auxiliary code.

Note About Ordering Parts

Most assemblies cannot be ordered as complete units; parts in the assemblies generally must be ordered separately.

A. Main Assembly & Refrigeration Circuit
F-2001MWH
 D-0 to G-1

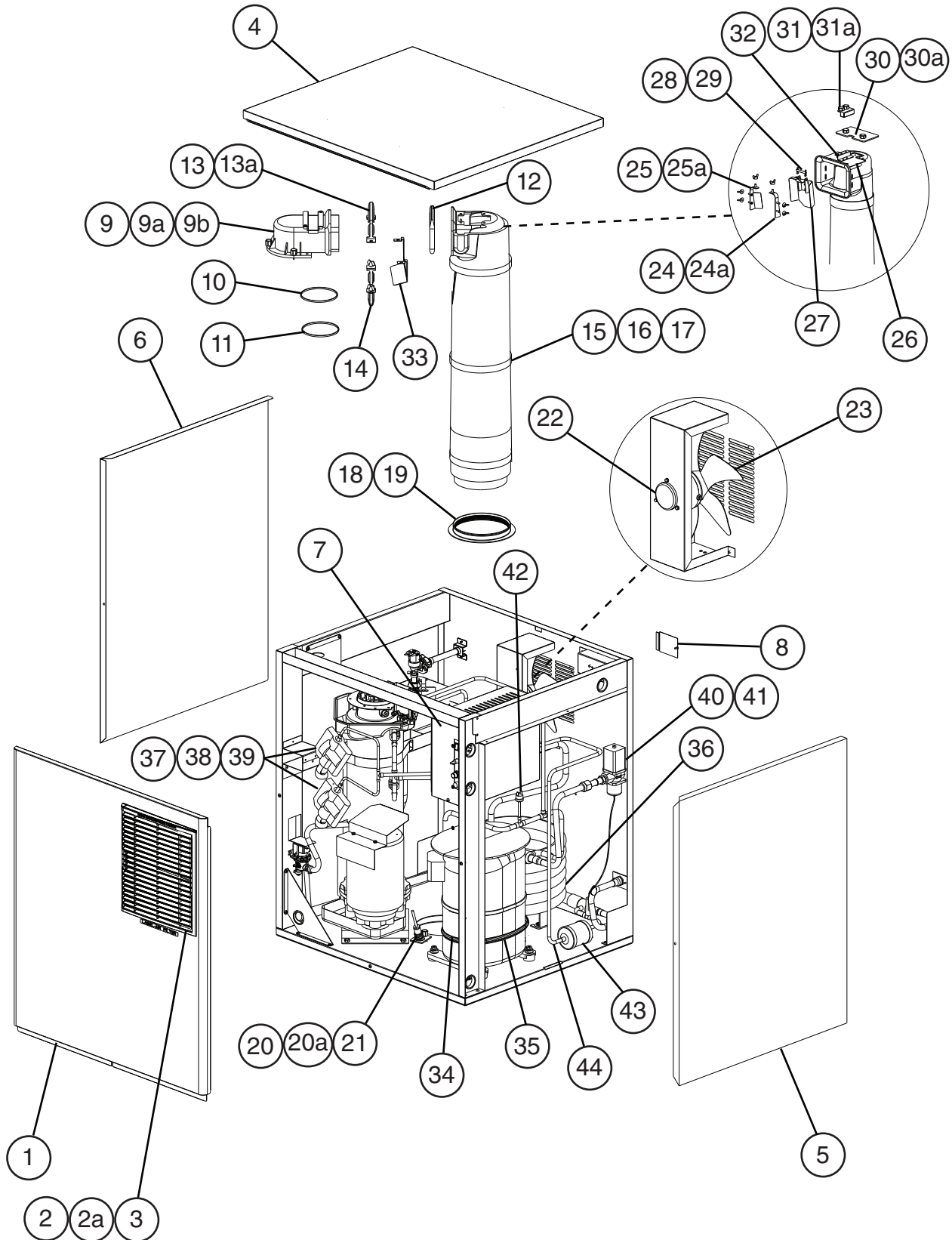

Title: A. Main Assembly & Refrigeration Circuit Model: F-2001MWH

Index No.	Description	Material or Model Number	Part Number	Required Number									
				D-0 to G-1									
Main Assembly													
1	Front Panel		2A2075-01	1									
2	Louver		1A0547-01	1									
2a	Push Retainer		4A2414-01	1									
3	Air Filter		2A2062G01	1									
4	Top Panel		2A2074-01	1									
5	Right Side Panel		2A2077G01	1									
6	Left Side Panel		2A2076G01	1									
7	Control Box Cover		3A7897-01	1									
8	Junction Box Cover		433410-01	1									
9	Spout		105378G01	1									
9a	Thumbscrew		415949G11	3									
9b	Spout Cover		4A5174-01	1									
10	O-Ring		4A4755-05	1									
11	Nylon Ring		431736-01	1									
12	Packing		327040-01	1									
13	Upper Strap		3A6912-02	1									
13a	Wing Nut		7E12-0600	2									
14	Lower Strap		3A6912-01	1									
15	Chute		216219-01	1									
16	Chute Insulation		216220-01	1									
17	Chute Tie		436531G02	3									
18	Chute Packing		432877-02	1									
19	Nylon Ring		327427-01	1									
20	Bin Control 1 Housing (infrared sensor)		3A3478-01	1									
20a	Thumbscrew		415949G11	1									
21	Bin Control 1 (infrared sensor)		4A4469-01	1									
22	Fan Motor		440917-01	1									
23	Fan Blade		434959-01	1									
24	Chute Baffle A		341012G01	1									
24a	Wing Nut		7E12-0400	3									
25	Chute Baffle B		341013G01	1									
25a	Wing Nut		7E12-0400	3									
26	Bin Control 2 Bracket (mechanical bin control)		3A1744G01	1									
27	Actuator		436848G02	1									
28	Shaft		436851-01	1									
29	Snap Pin		715S-0005	2									
30	Plate		4A2039-01	1									
30a	Thumbscrew		415949G10	2									
31	Bin Control 2 Proximity Switch (mechanical bin control)		4A2033-01	1									
31a	Thumbscrew		415949G08	2									
32	Truss Head Screw (ground)		7C32-0408	1									
33	Drip Guide		3A1628-01	1									

Title: A. Main Assembly & Refrigeration Circuit Model: F-2001MWH

Index No.	Description	Material or Model Number	Part Number	Required Number								
				D-0 to G-1								
Refrigeraton Circuit												
34	Compressor		4A4890-01	1								
35	Crankcase Heater		4A5397-02	1								
36	Condenser		3A7324-01	1								
37	Thermostatic Expansion Valve		4A1117-01	2								
38	Thermostatic Expansion Valve Cover		4A1168-01	2								
39	Thermostatic Expansion Valve Bulb Holder		4A5641-01	2								
40	Water Regulating Valve		4A1417-01	1								
41	Male Connector		445180-01	1								
42	High-Pressure Switch		463180-05	1								
43	Drier		4A1338-01	1								
44	Heat Exchanger		3A8023G01	1								

A. Main Assembly & Refrigeration Circuit
F-2001MRH(3)(-C)
 D-0 to H-0

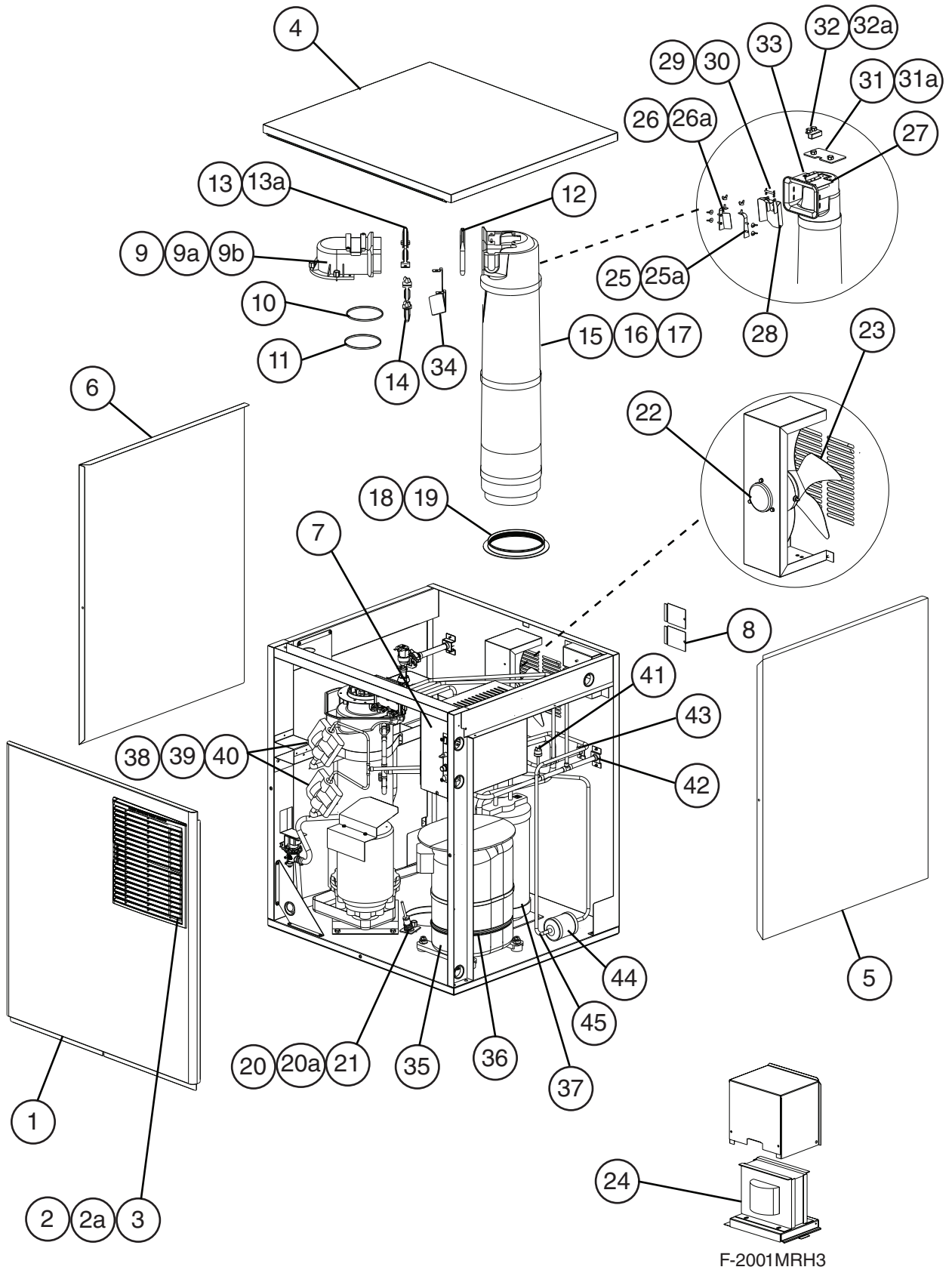

Title: A. Main Assembly & Refrigeration Circuit Model: F-2001MRH(3)(-C)

Index No.	Description	Material or Model Number	Part Number	Required Number									
				D-0 to H-0									
Main Assembly													
1	Front Panel		2A2075-01	1									
2	Louver		1A0547-01	1									
2a	Push Retainer		4A2414-01	1									
3	Air Filter		2A2062G01	1									
4	Top Panel		2A2074-01	1									
5	Right Side Panel		2A2077G01	1									
6	Left Side Panel		2A2076G01	1									
7	Control Box Cover		3A7897-01	1									
8	Junction Box Cover		433410-01	2									
9	Spout		105378G01	1									
9a	Thumbscrew		415949G11	3									
9b	Spout Cover		4A5174-01	1									
10	"O" Ring		4A4755-05	1									
11	Nylon Ring		431736-01	1									
12	Packing		327040-01	1									
13	Upper Strap		3A6912-02	1									
13a	Wing Nut		7E12-0600	2									
14	Lower Strap		3A6912-01	1									
15	Chute		216219-01	1									
16	Chute Insulation		216220-01	1									
17	Chute Tie		436531G02	3									
18	Packing		432877-02	1									
19	Nylon Ring		327427-01	1									
20	Bin Control 1 Housing (infrared sensor)		3A3478-01	1									
20a	Thumbscrew		415949G11	1									
21	Bin Control 1 (infrared sensor)		4A4469-01	1									
22	Fan Motor		440917-01	1									
23	Fan Blade		434959-01	1									
24	Main Transformer	F-2001MRH3	2U0128-01	1									
25	Chute Baffle A		341012G01	1									
25a	Wing Nut		7E12-0400	3									
26	Chute Baffle B		341013G01	1									
26a	Wing Nut		7E12-0400	3									
27	Bin Control 2 Bracket (mechanical bin control)		3A1744G01	1									
28	Actuator		436848G02	1									
29	Shaft		436851-01	1									
30	Snap Pin		715S-0005	2									
31	Plate		4A2039-01	1									
31a	Thumbscrew		415949G10	2									
32	Bin Control 2 Proximity Switch (mechanical bin control)		4A2033-01	1									
32a	Thumbscrew		415949G08	2									
33	Truss Head Screw (ground)		7C32-0408	1									
34	Drip Guide		3A1628-01	1									

Title: A. Main Assembly & Refrigeration Circuit Model: F-2001MRH(3)(-C)												
Index No.	Description	Material or Model Number	Part Number	D-0 to H-0	Required Number							
Refrigerator Circuit												
35	Compressor	F-2001MRH F-2001MRH-C F-2001MRH3	4A4890-01 4A4891-01	1 1								
36	Crankcase Heater		4A5397-02	1								
37	Receiver		438209-01	1								
38	Thermostatic Expansion Valve		4A1117-01	2								
39	Thermostatic Expansion Valve Cover		4A1168-01	2								
40	Thermostatic Expansion Valve Bult Holder		4A5641-01	2								
41	High-Pressure Switch		463180-04	1								
42	Discharge Line Coupling		434072-01	1								
43	Liquid Line Coupling		426554-01	1								
44	Drier		4A1338-01	1								
45	Heat Exchanger		3A8023G01	1								

A. Main Assembly & Refrigeration Circuit
F-2001MLH
 D-0 to G-1

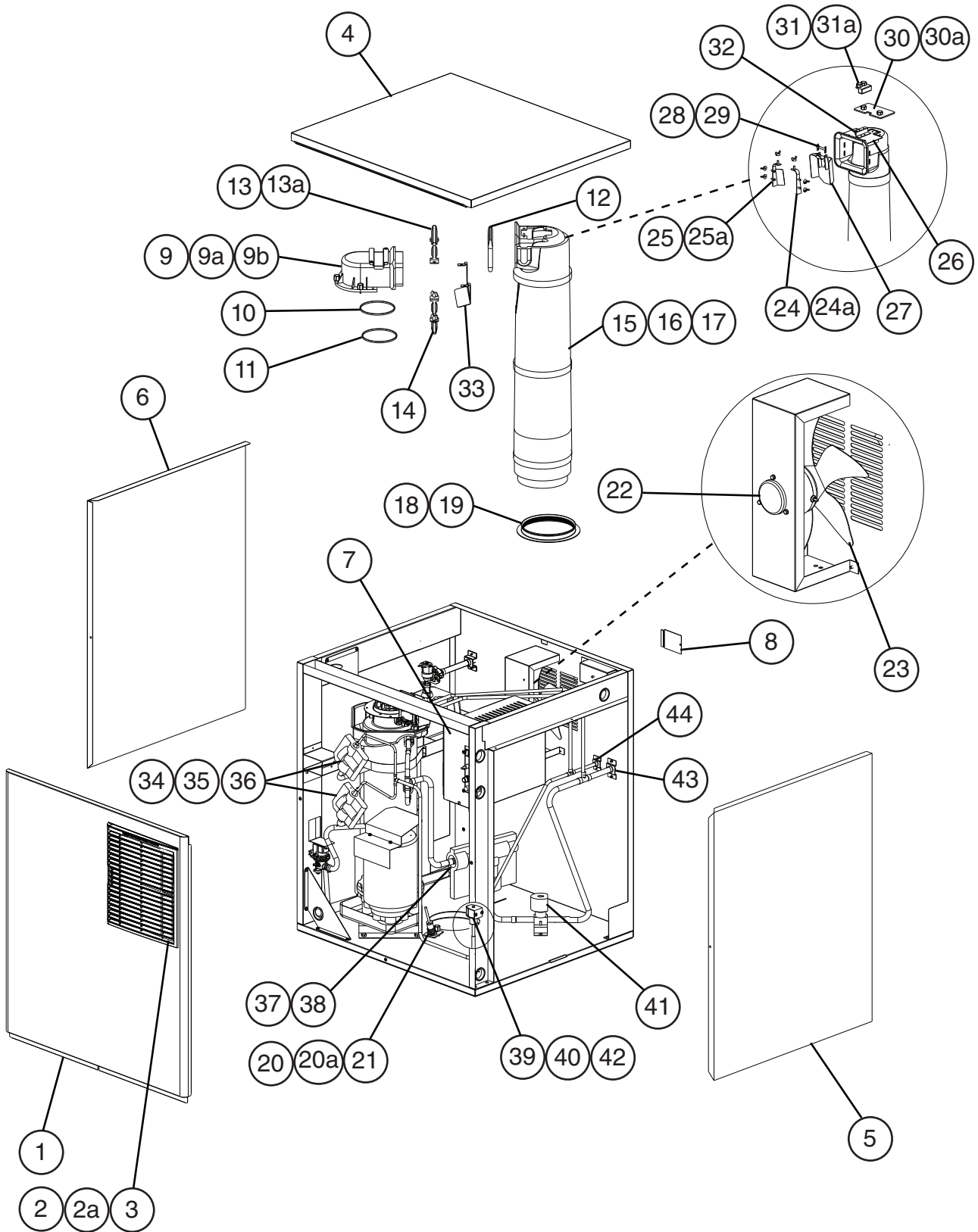

Title: A. Main Assembly & Refrigeration Circuit Model: F-2001MLH

Index No.	Description	Material or Model Number	Part Number	Required Number									
				D-0 to G-1									
Main Assembly													
1	Front Panel		2A2075-01	1									
2	Louver		1A0547-01	1									
2a	Push Retainer		4A2414-01	1									
3	Air Filter		2A2062G01	1									
4	Top Panel		2A2074-01	1									
5	Right Side Panel		2A2077G01	1									
6	Left Side Panel		2A2076G01	1									
7	Control Box Cover		3A7897-01	1									
8	Junction Box Cover		433410-01	1									
9	Spout		105378G01	1									
9a	Thumbscrew		415949G11	3									
9b	Spout Cover		4A5174-01	1									
10	"O" Ring		4A4755-05	1									
11	Nylon ring		431736-01	1									
12	Packing		327040-01	1									
13	Upper Strap		3A6912-02	1									
13a	Wing Nut		7E12-0600	2									
14	Lower Strap		3A6912-01	1									
15	Chute		216219-01	1									
16	Chute Insulation		216220-01	1									
17	Chute Tie		436531G02	3									
18	Chute Packing		432877-02	1									
19	Nylon Ring		327427-01	1									
20	Bin Control 1 Housing (infrared sensor)		3A3478-01	1									
20a	Thumbscrew		415949G11	1									
21	Bin Control 1 (infrared sensor)		4A4469-01	1									
22	Fan Motor		440917-01	1									
23	Fan Blade		434959-01	1									
24	Chute Baffle A		341012G01	1									
24a	Wing Nut		7E12-0400	3									
25	Chute Baffle B		341013G01	1									
25a	Wing Nut		7E12-0400	3									
26	Bin Control 2 Bracket (mechanical bin control)		3A1744G01	1									
27	Actuator		436848G02	1									
28	Shaft		436851-01	1									
29	Snap Pin		715S-0005	2									
30	Plate		4A2039-01	1									
30a	Thumbscrew		415949G10	2									
31	Bin Control 2 Proximity Switch (mechanical bin control)		4A2033-01	1									
31a	Thumbscrew		415949G08	2									
32	Truss Head Screw (ground)		7C32-0408	1									
33	Drip Guide		3A1628-01	1									

Title: A. Main Assembly & Refrigeration Circuit Model: F-2001MLH

Index No.	Description	Material or Model Number	Part Number	Required Number								
				D-0 to G-1								
Refrigeraton Circuit												
34	Thermostatic Expansion Valve		4A1117-01	2								
35	Thermostatic Expansion Valve Cover		4A1168-01	2								
36	Thermostatic Expansion Valve Bult Holder		4A5641-01	2								
37	Evaporator Pressure Regulator Valve		446872-02	1								
38	Evaporator Pressure Regulator Valve Cover		340434-01	1								
39	Liquid Line Valve Body		4A3276-01	1								
40	Valve Coil		4A3277-01	1								
41	Suction Line Valve		446873-01	1								
42	Strainer		4A1385-01	1								
43	Suction Line Coupling		448569-01	1								
44	Liquid Line Coupling		426554-01	1								

B. Ice Making Unit

F-2001MWH, F-2001MRH(3)(-C), F-2001MLH

D-0 to H-0

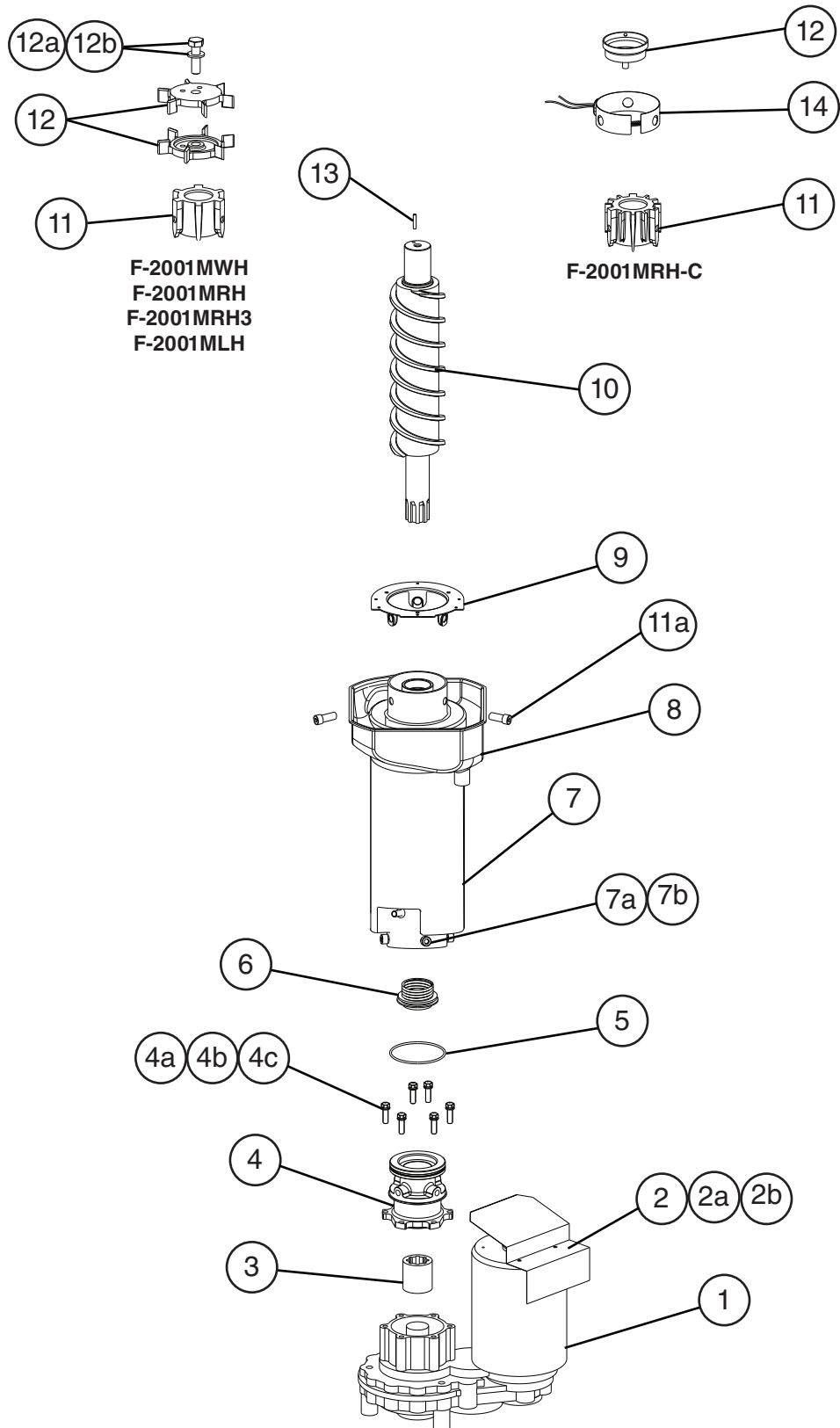

Title: B. Ice Making Unit Model: F-2001MWH, F-2001MRH(3)-(C), F-2001MLH												
Index No.	Description	Material or Model Number	Part Number	Required Number								
				D-0 to H-0								
1	Gear Motor		2U0129-01	1								
2	Gear Motor Barrier		3A1639-01	1								
2a	Truss Head Screw	4x8, SS	7C32-0408	2								
2b	Rubber Washer		4A5268-01	2								
3	Spline Coupling		420372-01	1								
4	Housing		206509G02	1								
4a	Hex Head Bolt	8x30, SS	4A5640-01	6								
4b	Plain Washer		7W22-0800	6								
4c	Split Lock Washer		7L22-0800	6								
5	"O" Ring		4A4755-04	1								
6	Mechanical Seal		432493-01	1								
7	Evaporator		2A7028G01	1								
7a	Socket Head Cap Screw		7S12-1020	4								
7b	Split Lock Washer		7L22-1000	4								
8	Drip Pan		2A6885-01	1								
9	Flange		352714-01	1								
10	Auger		120864G02	1								
11	Extruding Head	F-2001MWH F-2001MRH F-2001MRH3 F-2001MLH	216407G01	1								
		F-2001MRH-C	2A1594G01	1								
11a	Seal Bolt		474757G02	3								
12	Cutter	F-2001MWH F-2001MRH F-2001MRH3 F-2001MLH	327026-01	2								
		F-2001MRH-C	315736G01	1								
12a	Hex Head Bolt	F-2001MWH F-2001MRH F-2001MRH3 F-2001MLH	7B02-1035	1								
12b	Split Lock Washer	F-2001MWH F-2001MRH F-2001MRH3 F-2001MLH	7L22-1000	1								
13	Dowel Pin	F-2001MWH F-2001MRH F-2001MRH3 F-2001MLH	713S-0526	1								
14	Evaporator Heater	F-2001MRH-C	4A4335-01	1								

C. Water Circuit

F-2001MWH, F-2001MRH(3)(-C), F-2001MLH

D-0 to H-0

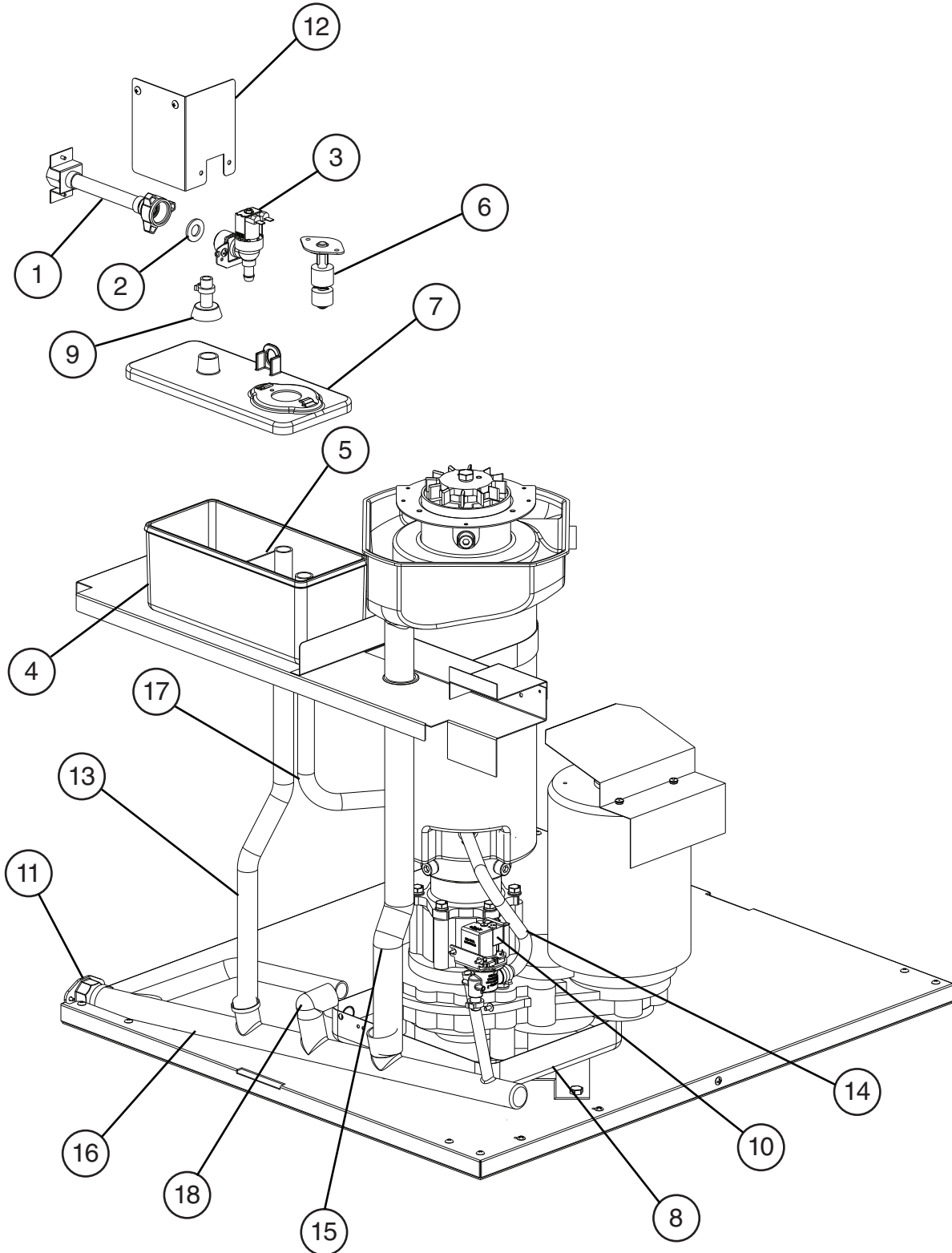

Title: C. Water Circuit Model: F-2001MWH, F-2001MRH(3)(-C), F-2001MLH

Index No.	Description	Material or Model Number	Part Number	Required Number									
				D-0 to H-0									
1	Water Supply Pipe		4A0891G02	1									
2	Washer		413854-03	1									
3	Inlet Water Valve		4A5309-01	1									
4	Reservoir		208125-01	1									
5	Reservpor Seperator		423538-02	1									
6	Float Switch		435490-01	1									
7	Reservoir Cover		208126-01	1									
8	Drain Pan		219358G01	1									
9	Reservoir Inlet		4A0869-01	1									
10	Drain Valve		4A2772-02	1									
11	Drain Fitting		4A5528-01	1									
12	Inlet Water Valve Bracket		3A6393-01	1									
13	Vinyl Hose		7725-1923	1									
14	Silicone Hose		7730I3896	1									
15	Vinyl Hose		4A0658L01	1									
16	Drain Hose		3A7490-01	1									
17	Reservoir Drain Hose		7730-1519	1									
18	Elbow		4A5624-01	1									
Hose Clamps													
	Hose Clamp		4A2017-02	1									
	Hose Clamp		4A2017-05	1									
	Hose Clamp		4A2017-08	1									

D. Control Box Assembly

F-2001MWH, F-2001MRH(3)(-C), F-2001MLH

D-0 to H-0

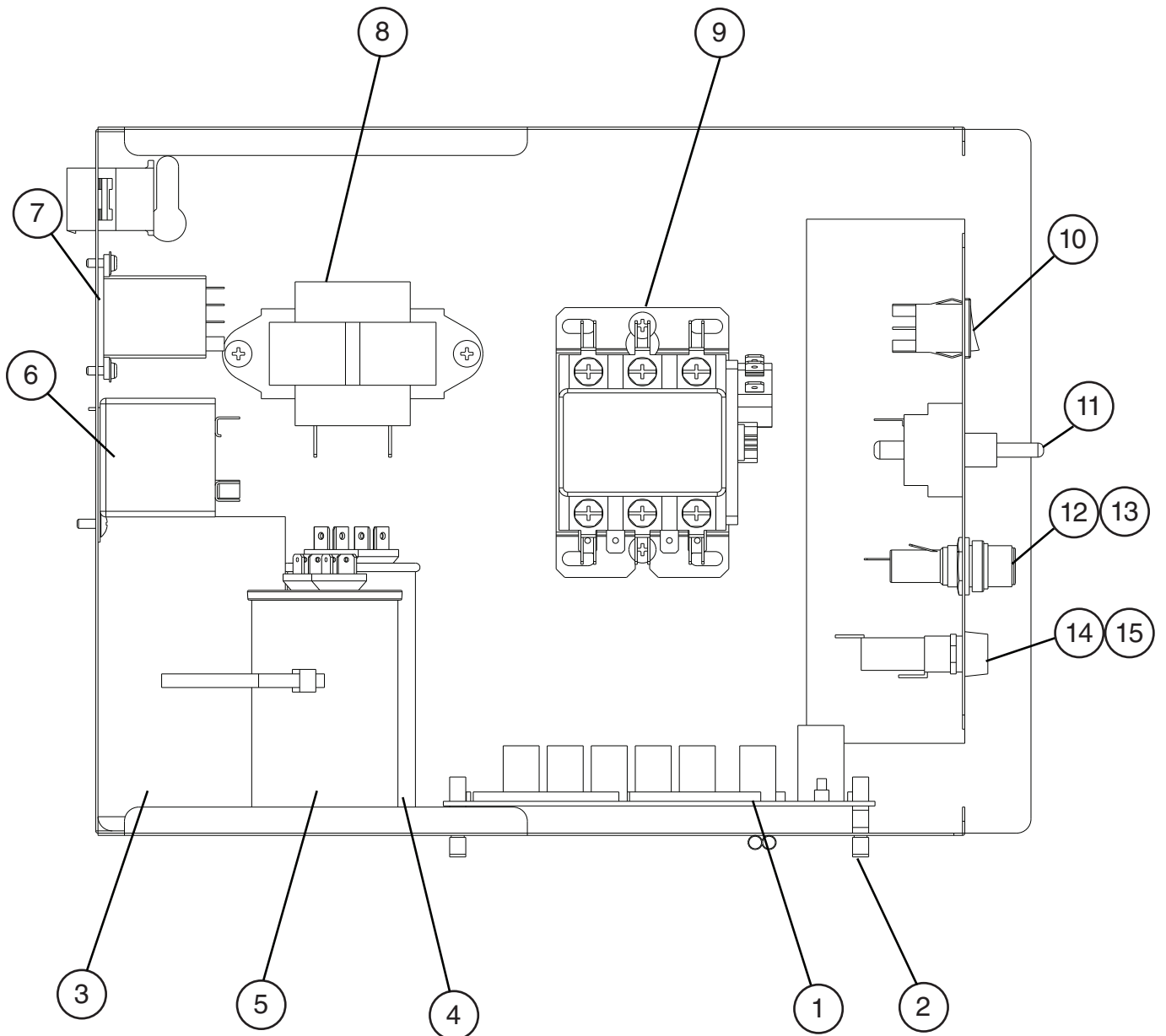

Title: D. Control Box Assembly Model: F-2001MWH, F-2001MRH(3)(-C), F-2001MLH													
Index No.	Description	Material or Model Number	Part Number	Required Number									
				D-0 to H-0									
1	Control Board		2A8054-01	1									
2	Control Board Support		4A0336-03	4									
3	Start Capacitor	F-2001MWH F-2001MRH F-2001MRH-C	3A0076-12	1									
4	Run Capacitor	F-2001MWH F-2001MRH F-2001MRH-C	3A2005-13	1									
5	Gear Motor Capacitor		4A5450-01	1									
6	Start Relay		4A1107-09	1									
7	Compressor Control Relay		406132-07	1									
8	Control Transformer		4A0557-01	1									
9	Magnetic Contactor		4A0794-01	1									
10	Control Switch		4A0558-01	1									
11	Power Switch		4A2332-01	1									
12	Fuse Holder (Control)		4A5443-01	1									
13	Fuse (Control)	1A, 250VAC	4A0893-01	1									
14	Fuse Holder (Gear Motor)		4A3449-02	1									
15	Fuse (Gear Motor)	7A, 125V Slow Blow	4A3804-01	1									

E. Accessories & Labels

F-2001MWH, F-2001MRH(3)(-C), F-2001MLH

D-0 to H-0

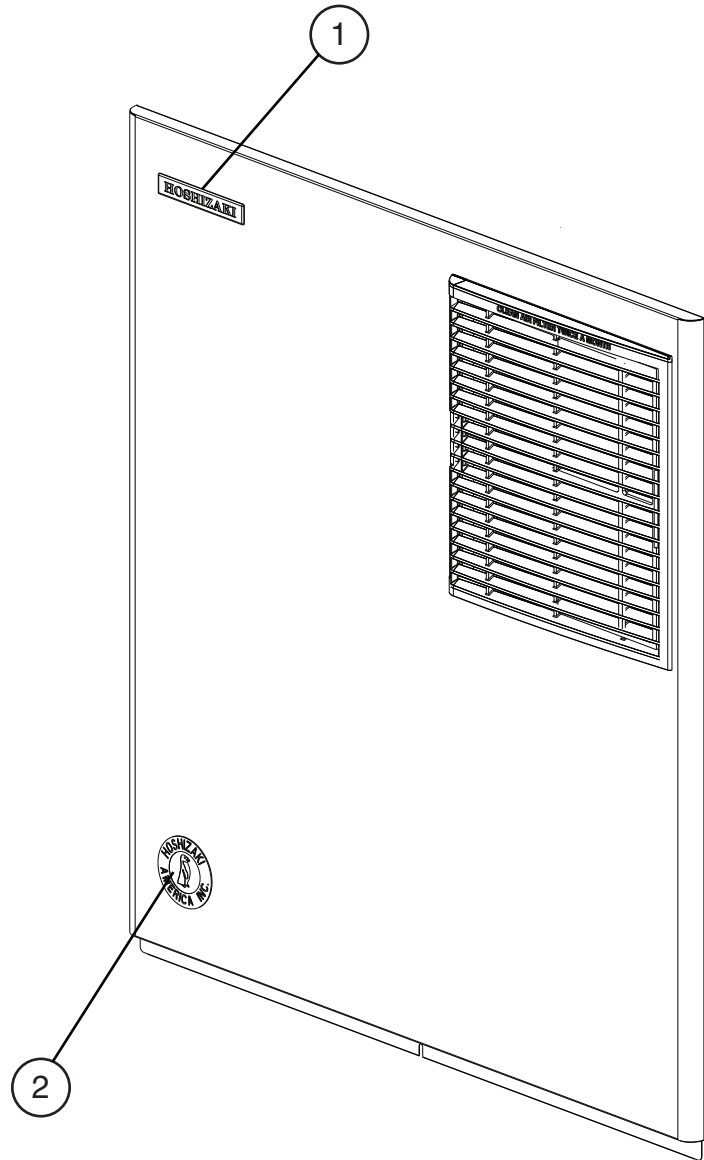

Title: E. Accessories & Labels Model: F-2001MWH, F-2001MRH(3)(-C), F-2001MLH										
Index No.	Description	Material or Model Number	Part Number	Required Number						
				D-0 to H-0						
1	Hoshizaki Emblem Label		4A0560-01	1						
2	Penguin Label		475552L02	1						
3	Universal Brace		4A0363-01	2						