



HOSHIZAKI

Service Manual

Self-Contained Flaker

Models
F-330BAJ(-C)



hoshizakiamerica.com

Number: 73211
Issued: 2-17-2017
Revised: 4-24-2025

⚠ WARNING

Only qualified service technicians should install and service the appliance. To obtain the name and phone number of your local Hoshizaki Certified Service Representative, visit www.hoshizaki.com. No service should be undertaken until the technician has thoroughly read this Service Manual. Failure to service and maintain the appliance in accordance with this manual will adversely affect safety, performance, component life, and warranty coverage and may result in costly water damage. Proper installation is the responsibility of the installer. Product failure or property damage due to improper installation is not covered under warranty.

Hoshizaki provides this manual primarily to assist qualified service technicians in the service of the appliance.

Should the reader have any questions or concerns which have not been satisfactorily addressed, please call, send an e-mail message, or write to the Hoshizaki Technical Support Department for assistance.

Phone: 1-800-233-1940; (770) 487-2331

Fax: 1-800-843-1056; (770) 487-3360

E-mail: techsupport@hoshizaki.com

HOSHIZAKI AMERICA, INC.

618 Highway 74 South

Peachtree City, GA 30269

Attn: Hoshizaki Technical Support Department

Web Site: www.hoshizaki.com

NOTE: To expedite assistance, all correspondence/communication **MUST** include the following information:

- Model Number _____
- Serial Number _____
- Complete and detailed explanation of the problem.

IMPORTANT

This manual should be read carefully before the appliance is serviced. Read the warnings and guidelines contained in this manual carefully as they provide essential information for the continued safe use, service, and maintenance of the appliance. Retain this manual for any further reference that may be necessary.

CONTENTS

Important Safety Information	5
I. Construction and Water/Refrigeration Circuit Diagram	7
A. Construction	7
B. Icemaking Unit	8
C. Water/Refrigeration Circuit Diagram.....	9
II. Sequence of Operation and Service Diagnosis	10
A. Sequence of Operation Flow Chart.....	10
1. Icemaking and Drain Cycle	10
2. Shutdown	11
B. Service Diagnosis	12
1. Ice Production Check	12
2. Diagnostic Procedure.....	13
C. Control Board Check.....	18
D. Bin Control Check	22
E. Float Switch Check and Cleaning	24
F. Diagnostic Tables.....	26
III. Controls and Adjustments	28
A. Control Board	28
1. Control Board Layout Shown:.....	29
2. LED Lights and Audible Alarm Safeties	30
3. Ice Purge Cycle Bypass.....	31
B. Controls and Adjustments	31
1. Default Dip Switch Settings	31
2. Infrared Sensor Shutdown Delay (S1 dip switch 1, 2, 3)	32
3. Drain Frequency Control (S1 dip switch 4)	32
4. Continuous Dispensing Timer (S1 dip switch 5 & 6)	32
5. Bin Control Selector (S1 dip switch 7)	33
6a. Mechanical Shutdown Delay (S1 dip switch 8) Auxiliary Code E-0:	33
6b. Agitation and Ice Purge Timer (S1 dip switch 8) Auxiliary Code F-0 and Later: ...	33
7. Mechanical Shutdown Delay (S1 dip switch 9) Auxiliary Code F-0 and Later	34
8a. Factory Use (S1 Dip Switch 9 & 10) Auxiliary Code E-0.....	34
8b. Factory Use (S1 Dip Switch 10) Auxiliary Code F-0 and Later.....	34
C. Power Switch and Control Switch.....	35

IV. Refrigeration Circuit and Component Service Information.....	36
A. Refrigeration Circuit Service Information	36
B. Component Service Information.....	39
V. Maintenance	47
VI. Disposal.....	49
VII. Technical Information.....	50
A. Specification & Performance Data Sheets	50
1. F-330BAJ	50
2. F-330BAJ-C	51
B. Wiring Diagram.....	52

Important Safety Information

Throughout this manual, notices appear to bring your attention to situations which could result in death, serious injury, damage to the appliance, or damage to property.

⚠ WARNING Indicates a hazardous situation which could result in death or serious injury.

NOTICE Indicates a situation which could result in damage to the appliance or property.

IMPORTANT Indicates important information about the use and care of the appliance.

⚠ WARNING

The appliance should be destined only to the use for which it has been expressly conceived. Any other use should be considered improper and therefore dangerous. The manufacturer cannot be held responsible for injury or damage resulting from improper, incorrect, and unreasonable use. Failure to install, operate, service and maintain the appliance in accordance with this manual will adversely affect safety, performance, component life, and warranty coverage and may result in costly water damage.

To reduce the risk of death, electric shock, serious injury, or fire, follow basic precautions including the following:

- Only qualified service technicians should install and service the appliance.
- The appliance must be installed in accordance with applicable national, state, and local codes and regulations. Failure to meet these code requirements could result in death, electric shock, serious injury, fire, or damage to the appliance.
- To reduce the risk of electric shock, do not touch the appliance power switch or plug with damp hands.
- Make sure the appliance power switch is in the "OFF" position before plugging in or unplugging the appliance.
- Before servicing, move the power switch to the "OFF" position. Unplug the appliance from the electrical outlet.
- The appliance requires an independent power supply of proper capacity. See the nameplate for electrical specifications. Failure to use an independent power supply of proper capacity can result in a tripped breaker, blown fuse, damage to existing wiring, or component failure. This could lead to heat generation or fire.
- **THE APPLIANCE MUST BE GROUNDED.** The appliance is equipped with a NEMA 5-15 three-prong grounding plug  to reduce the risk of potential shock hazards. It must be plugged into a properly grounded, independent 3-prong wall outlet. If the outlet is a 2-prong outlet, it is your personal responsibility to have a qualified electrician replace it with a properly grounded, independent 3-prong wall outlet. Do not remove the ground prong from the power cord and do not use an adapter plug. Failure to properly ground the appliance could result in death or serious injury.
- Do not make any alterations to the appliance. Alterations could result in electric shock, injury, fire, or damage to the appliance.

⚠ WARNING, continued

- Do not use an extension cord.
- Do not use an appliance with a damaged power cord. The power cord should not be altered, jerked, bundled, weighed down, pinched, or tangled. Such actions could result in electric shock or fire. To unplug the appliance, be sure to pull the plug, not the cord, and do not jerk the cord.
- The GREEN ground wire in the factory-installed power cord is connected to the appliance. If it becomes necessary to remove or replace the power cord, be sure to connect the power cord's ground wire.
- Do not place fingers or any other objects into the ice discharge opening.
- The appliance is not intended for use by persons (including children) with reduced physical, sensory, or mental capabilities, or lack of experience and knowledge, unless they have been given supervision or instruction concerning use of the appliance by a person responsible for their safety.
- Children should be properly supervised around this appliance.
- Do not climb, stand, or hang on the appliance or allow children or animals to do so. Serious injury could occur or the appliance could be damaged.
- Do not use combustible spray or place volatile or flammable substances near the appliance. They might catch fire.
- Keep the area around the appliance clean. Dirt, dust, or insects in the appliance could cause harm to individuals or damage to the appliance.

NOTICE

- Follow the instructions in this manual carefully to reduce the risk of costly water damage.
- In areas where water damage is a concern, install in a contained area with a floor drain.
- Install the appliance in a location that stays above freezing. Normal operating ambient temperature must be within 45°F to 100°F (7°C to 38°C).
- Do not leave the appliance on during extended periods of non-use, extended absences, or in sub-freezing temperatures.
- Do not place objects on top of the appliance.
- The ice storage bin is for ice use only. Do not store anything else in the ice storage bin.

I. Construction and Water/Refrigeration Circuit Diagram

A. Construction

1. F-330BAJ(-C)

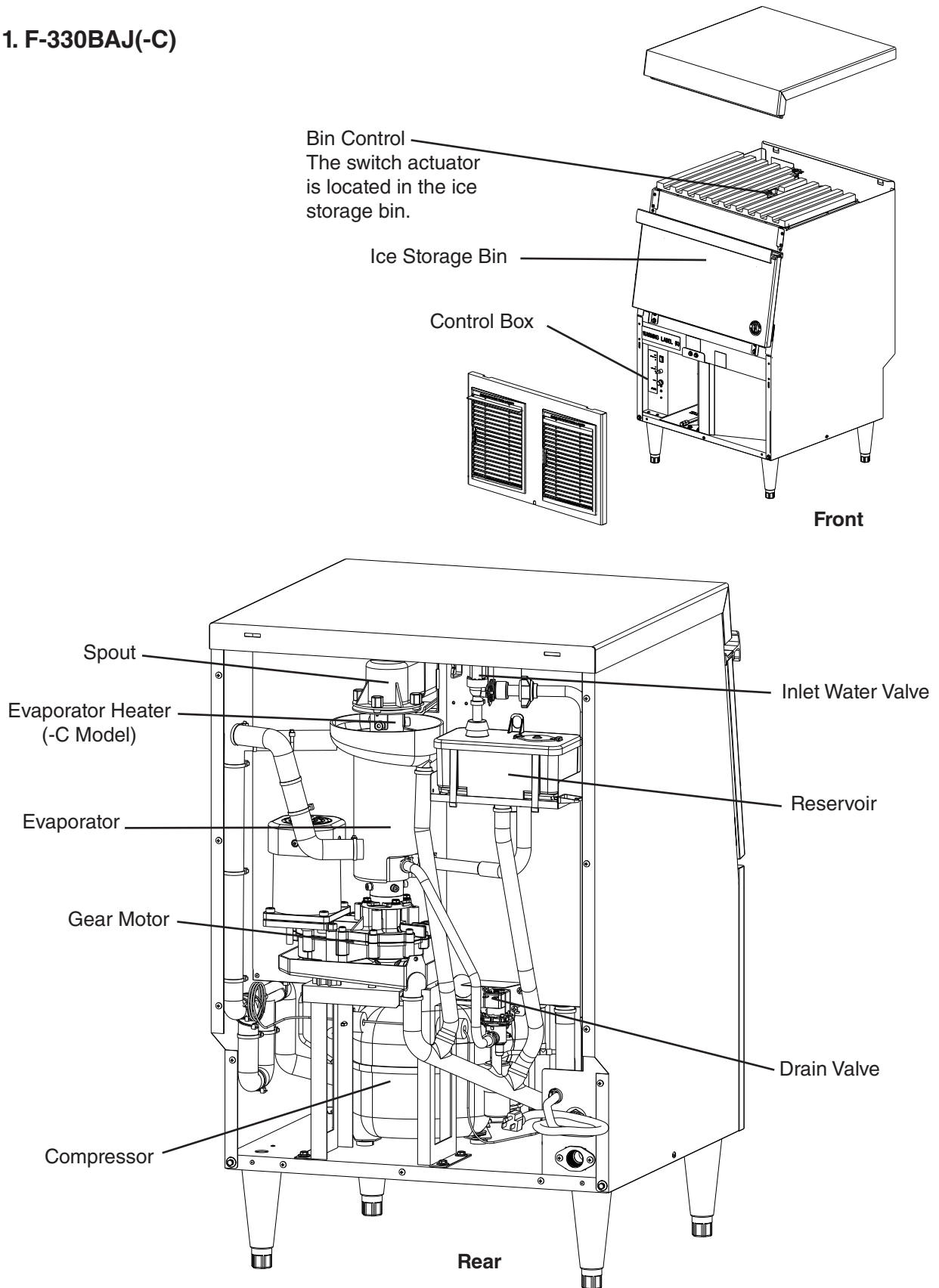

B. Icemaking Unit

1. F-330BAJ(-C)

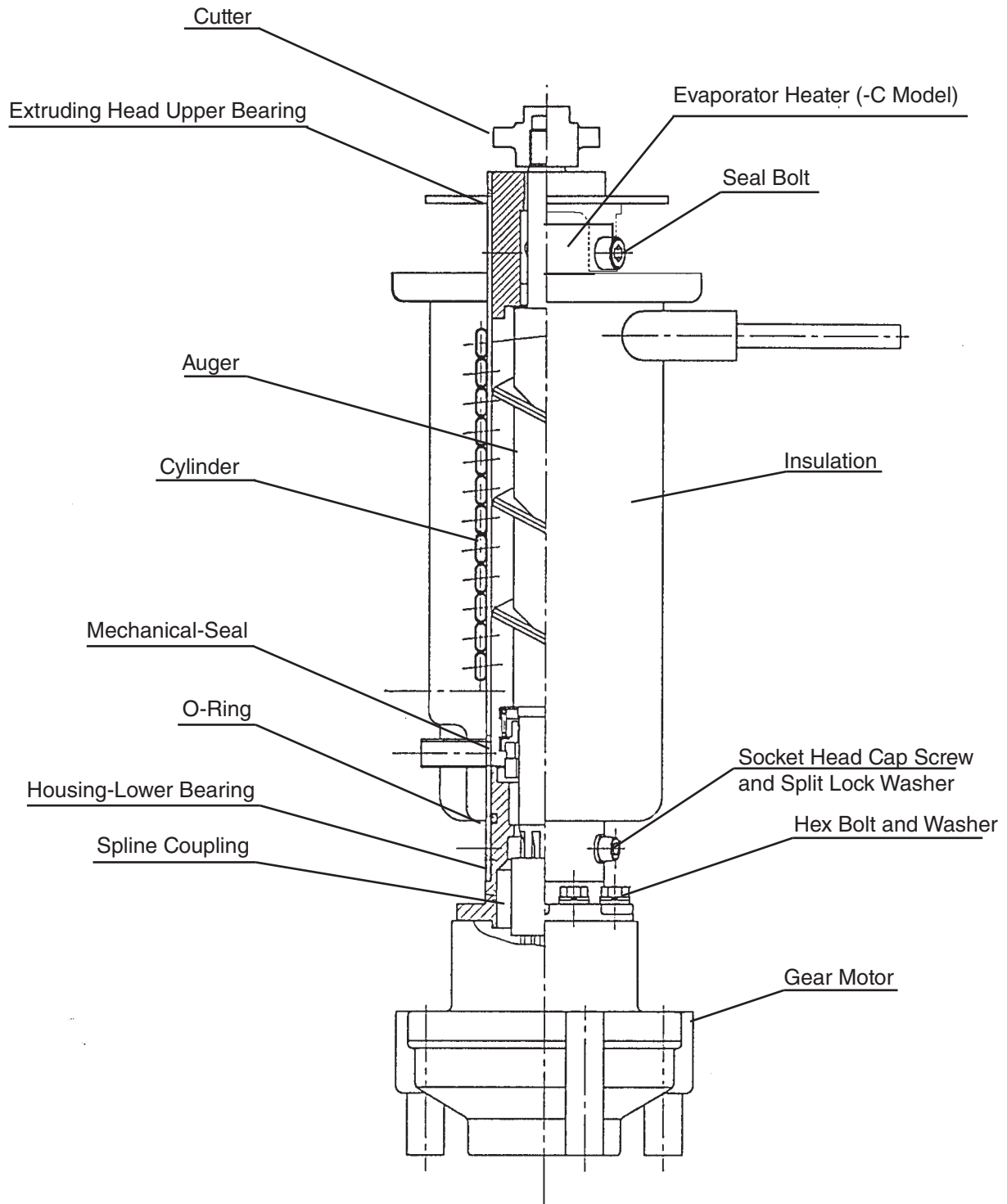

C. Water/Refrigeration Circuit Diagram

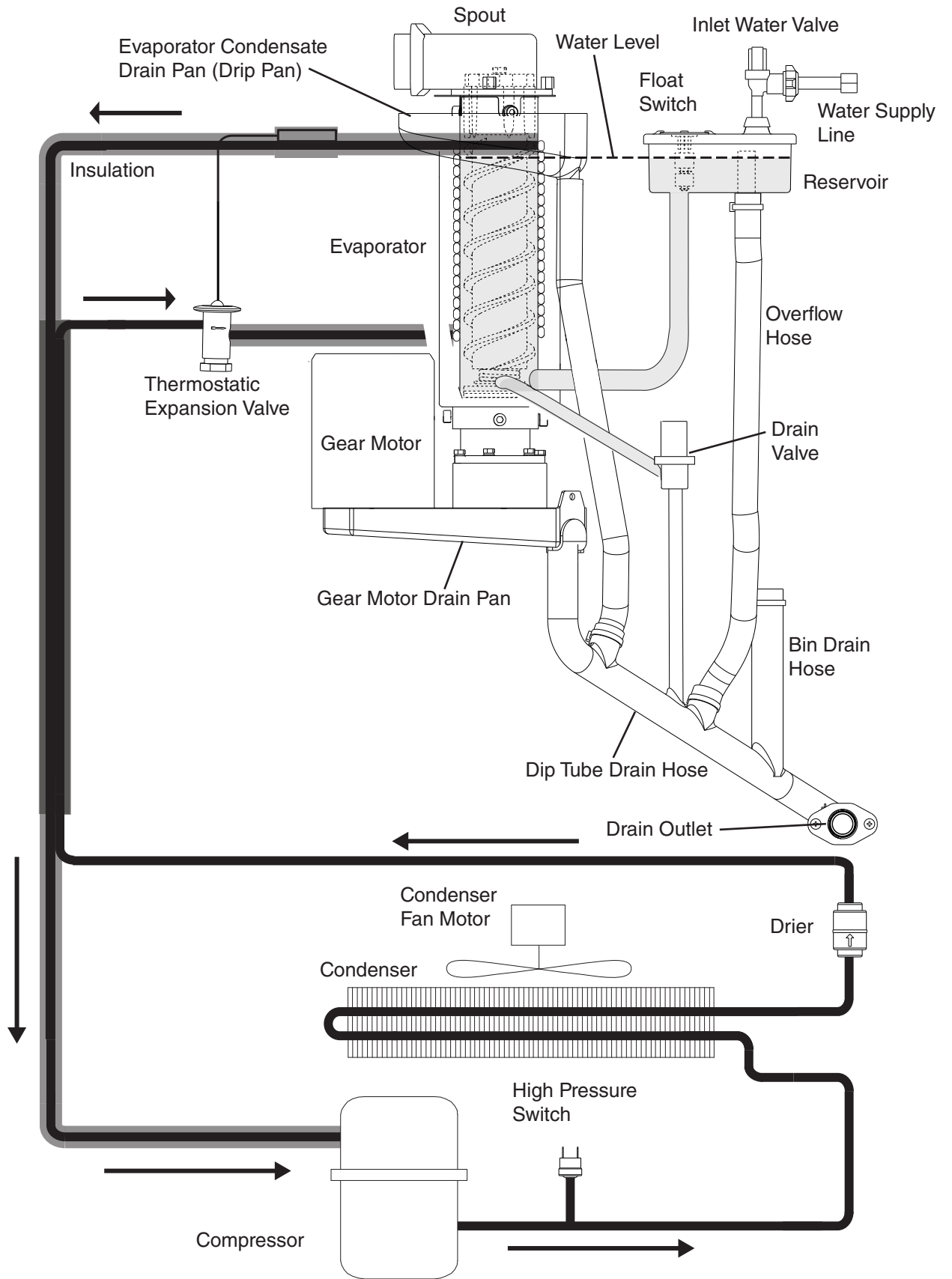

II. Sequence of Operation and Service Diagnosis

A. Sequence of Operation Flow Chart

1. Icemaking and Drain Cycle

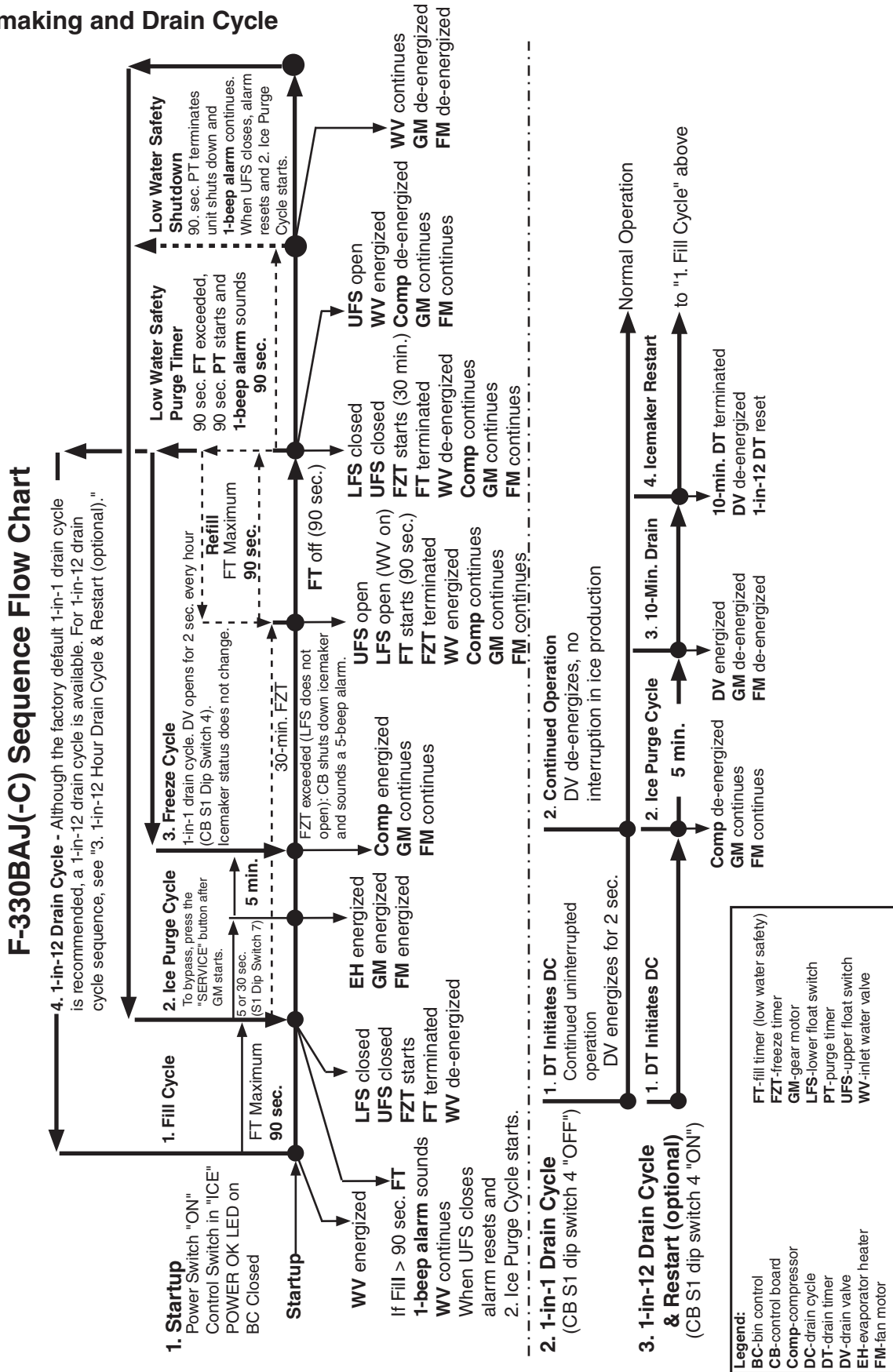

2. Shutdown

Control Board Sequence of Operation Flow Chart - Shutdown

4a. Bin Control Shutdown & Restart Auxiliary Code: E-0

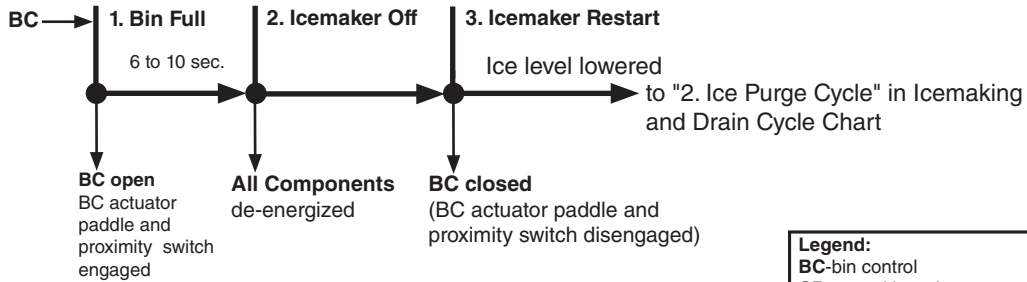

Legend:
BC-bin control
CB-control board
Comp-compressor
FM-fan motor
GM-gear motor

4b. Bin Control Shutdown & Restart Auxiliary Code F-0 and Later

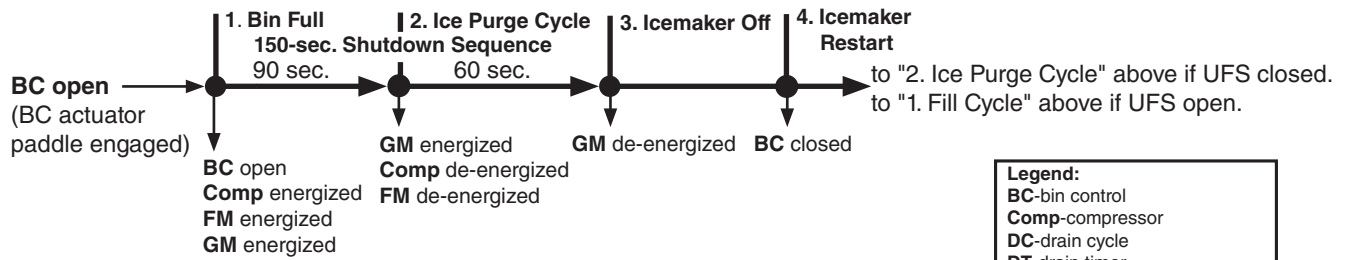

Legend:
BC-bin control
Comp-compressor
DC-drain cycle
DT-drain timer
DV-drain valve
FM-fan motor
FT-fill timer (low water safety)
GM-gear motor
LFS-lower float switch
PT-purge timer
UFS-upper float switch
WV-inlet water valve

B. Service Diagnosis

WARNING

- The appliance should be diagnosed and repaired only by qualified service personnel to reduce the risk of death, electric shock, serious injury, or fire.
- Risk of electric shock. Use extreme caution and exercise safe electrical practices.
- Moving parts (e.g., fan blade or auger) can crush and cut. Keep hands clear.
- **CHOKING HAZARD:** Ensure all components, fasteners, and thumbscrews are securely in place after the appliance is serviced. Make sure that none have fallen into the ice storage bin.
- Make sure all food zones in the icemaker and ice storage bin are clean after service.

1. Ice Production Check

To check production, prepare a bucket or pan to catch the ice and a set of scales to weigh the ice. After the appliance has operated for 10 to 20 minutes, catch the ice production for 10 minutes. Weigh the ice to establish the batch weight. Multiply the batch weight by 144 for the total production in 24 hours. When confirming production or diagnosing low production, reference production information to the performance data charts found in "VII.A. Specification and Performance Data Sheets."

2. Diagnostic Procedure

This diagnostic procedure is a sequence check that allows you to diagnose the electrical system and components. Before proceeding, check for correct installation, proper voltage per appliance nameplate, and adequate water pressure (10 PSIG to 113 PSIG).

Note: • When checking high voltage (115VAC), always choose a neutral (W) wire to establish a good neutral connection.

- When checking low voltage (24VAC), always choose a neutral (LBU) wire to establish a good neutral connection.
 - When checking control board DC voltage (5VDC), always place the red positive test lead from the multimeter to CB K5 pin closest to CB K4 connector. See "II.C. Control Board Check."
 - To speed up the diagnostic process, the 5-min. ice purge cycle may be bypassed by pressing the "SERVICE" button on the control board after the gear motor starts. **WARNING! Risk of electric shock. Care should be taken not to touch live terminals.**
 - If the icemaker is in alarm, see "III.A.2. LED Lights and Audible Alarm Safeties."
 - FM and EH (-C model) energize when "GM" LED turns on.
 - CB monitors the following switches with 5VDC during the icemaking process: Control Switch (CS), High-Pressure Switch (HPS), Float Switch (FS), Compressor Control Relay/Gear Motor Protect Relay (CCR/GMPR), and Bin Control (mechanical stand-alone). When 5VDC is present across any of these switches, the switch is open.
- 1) Remove the front panel, then move the power switch to the "OFF" position. Move the control switch to the "DRAIN" position, then move the power switch back to the "ON" position. Replace the front panel in its correct position.
 - 2) Allow the water system to drain for 5 min.
 - 3) Remove the front panel. Move the power switch to the "OFF" position, then turn off the power supply.
 - 4) Remove the control box cover and access CB.
 - 5) Check the CB S1 dip switch settings, see "III.B.1. Default Dip Switch Settings" to assure that they are in the correct positions. For proper operation of BC (mechanical stand-alone), confirm that S1 dip switch 7 is in the "OFF" position.

6) **Startup–CB "POWER OK" LED is on.** Turn on the power supply, then move the power switch to the "ON" position. Make sure the control switch is in the "ICE" position. CB "POWER OK" LED turns on.

Diagnosis CB "POWER OK" LED: Check that CB "POWER OK" LED is on. If not, check for 115VAC at control transformer black (BK) wire to neutral (W). If 115VAC is not present, check the power switch, power supply cord, and breaker. If 115VAC is present, check control transformer continuity. Replace as needed. Next, check for 24VAC at control transformer red (R) wire to neutral (LBU). If 24VAC is not present, check control transformer continuity. Replace as needed. If 24VAC is present, check 24VAC 3A fuse. If fuse is good, check for 24VAC at CB K8 #1 (W/R) to CB K8 #2 (LBU). If 24VAC is present and "POWER OK" LED is off, replace CB.

Diagnosis BC (mechanical stand-alone): Check that the actuator paddle is properly positioned. Check continuity across BC. If open, replace BC. Next, check VDC at CB K8 #3 (GY) to CB K8 #4 (GY). When BC is closed 0VDC is read. Move the actuator paddle to open BC(2). When open, 5VDC is present between CB K8 #3 (GY) and CB K8 #4 (GY). If 5VDC is not present when BC is open, replace CB. Return actuator to its normal position.

7) **Fill Cycle – "WTRIN" LED is on.** Reservoir is empty and LFS and UFS are open. 90-sec. FT starts. WV energizes and fill cycle starts. LFS closes. Nothing occurs at this time. Reservoir continues to fill until UFS closes. When UFS closes, WV de-energizes, 90-sec. FT is terminated, and CB "WTRIN" LED turns off. 30-min. FZT and 5-sec. GM delay timer start. If UFS remains open longer than 90 sec. after LFS opens, FT exceeded and CB sounds a 1-beep alarm. WV remains energized until UFS closes. Alarm resets automatically when UFS closes. **Diagnosis:** If reservoir is empty and "WTRIN" LED is off, confirm LFS status. See "II.E. Float Switch Check and Cleaning." If LFS is open and "WTRIN" LED is off, replace CB. If "WTRIN" LED is on, check that the reservoir fills. If not, check water supply line shut-off valve, water filters, and WV screen. If "WTRIN" LED is on and WV is off, check CB K2 #8 (O) to a neutral (LBU) for 24VAC. If 24VAC is not present, check CB K2 #9 (W/R) to a neutral (LBU) for 24VAC. If 24VAC is present on CB K2 #9 (W/R) and not on CB K2 #8 (O), replace CB. If 24VAC is present on CB K2 #8 (O), check continuity through WV solenoid. If open, replace WV. If WV is energized and refill exceeds FT with no water in the reservoir, check for DV leaking. If reservoir is full and overflowing check for open UFS. See "II.E. Float Switch Check and Cleaning." If UFS is closed, check that WV de-energizes. If not, check CB K2 #8 (O) to a neutral (LBU) for 24VAC. If 24VAC is present, replace CB. If WV de-energizes and water continues to fill the reservoir, replace WV.

- 8) **Ice Purge Cycle – "GM" LED is on.** 5-sec. GM delay timer terminates. GM, CCR, FM, and EH (-C model) energize. Once CCR energizes, 5VDC circuit closes through CCR terminal #3 (W/O) and terminal #5 (W/O) and CB K9 #5 (W/O) and K9 #6 (W/O). After 5VDC circuit closes, 5-min. ice purge timer starts. To bypass the 5-min. Ice Purge Cycle, press the "SERVICE" button on CB after the "GM" LED turns on. **WARNING! Risk of electric shock. Care should be taken not to touch live terminals.** **Diagnosis:** If "GM" LED is off, check that UFS closes and WV de-energizes. If UFS is closed, 30 sec. has passed, and "GM" LED remains off, replace CB. If "GM" LED is on and GM is off, check CB K1 #2 (BK) to a neutral (W) for 115VAC. If 115VAC is not present, check 115VAC power supply. If 115VAC is present, check CB K1 #3 (P) to a neutral (W). If 115VAC is present on CB K1 #2 (BK) and not on CB K1 #3 (P), replace CB. If 115VAC is present on CB K1 #3 (P), check GM fuse, GM internal protector, GM windings and capacitor, and GM coupling between auger and GM. When GM energizes, CCR energizes starting 5-min. ice purge timer. If FM does not start, check FM capacitor, FM windings, and FM bearings.
- 9) **Freeze Cycle – "COMP" and "GM" LEDs are on.** The 5-min. ice purge timer terminates. GM, EH (-C model), CCR, and FM continue. Comp energizes. Ice production starts 4 to 6 min. after Comp energizes depending on ambient and water conditions. As ice is produced, the water level in the reservoir drops. UFS opens. Nothing happens at this time. When LFS opens, WV energizes and refill cycle begins, FZT terminates, and FT starts.
- FZT: 30-Min. Freeze Safety Timer** – FZT starts when UFS closes and terminates when LFS opens. If LFS does not open within 30 min. of UFS closing, CB shuts down the icemaker and sounds a 5-beep alarm. See "III.A.2. LED Lights and Audible Alarm Safeties." To reset, turn the power supply off and on again. See "II.F. Diagnostic Tables" for troubleshooting details.
- Icemaker Diagnosis (CCR):** 5-min. ice purge timer terminates, CB "COMP" LED is on and COMP energizes. If not, check for 5VDC between CB K5 connector pin closest to CB K4 connector and CB K9 connector #5 (W/O). If 5VDC is not present, replace CB. If 5VDC is present, check for 5VDC between CB K5 connector pin closest to CB K4 connector and CB K9 connector #6 (W/O). If 5VDC is present and CB "Comp" LED is off (CR or COMP not energized), replace CB. If 5VDC is not present, check for 115VAC between CCR terminal #7 (O) to CCR terminal #8 (W) for 115VAC. If 115VAC is not present (GM not energized), see step 8 above. If 115VAC is present and CCR contacts are open (5VDC present between terminals #3 (W/O) and #5 (W/O)), check CCR solenoid voltage and solenoid continuity. Replace CCR if necessary.
- Icemaker Diagnosis (COMP):** If "COMP" LED is on and COMP is not energized, check CB X1 relay BK wire to a neutral (W) and CB X1 relay V wire to a neutral (W) for 115VAC. If 115VAC is present on CB X1 BK wire and not on CB X1 V wire, replace CB. If 115VAC is present on CB X1 V wire and COMP is not energized, check for 115VAC at CB X1 Comp relay. Check Comp internal overload (motor protector), start relay, and capacitors.

10) **Refill Cycle – "GM", "COMP", and "WTRIN" LEDs are on.**

LFS opens. WV energizes and 90-sec. FT starts. Comp, GM, CCR, and FM continue. LFS closes. Nothing occurs at this time. Reservoir continues to fill until UFS closes. When UFS closes, WV de-energizes, 90-sec. FT terminates, and 30-min. FZT starts. If UFS remains open longer than 90 sec. after LFS opens, FT exceeded and CB sounds a 1-beep alarm. WV remains energized until UFS closes. Alarm resets automatically when UFS closes.

Diagnosis – Confirm that the water level has dropped and the UFS and LFS are open. See "II.E. Float Switch Check and Cleaning." Check that "WTRIN" LED is on. If LFS is open and "WTRIN" LED is off, replace CB. If "WTRIN" LED is on, check that the reservoir fills. If not, check water supply line shut-off valve, water filters, and WV screen. If "WTRIN" LED is on and WV is off, check CB K2 #8 (O) to a neutral (LBU) for 24VAC. If 24VAC is not present, check CB K2 #9 (W/R) to a neutral (LBU) for 24VAC. If 24VAC is present on CB K2 #9 (W/R) and not on CB K2 #8 (O), replace CB. If 24VAC is present on CB K2 #8 (O), check continuity through WV solenoid. If open, replace WV. If WV is energized and refill exceeds FT with no water in the reservoir, check for DV leaking. If reservoir is full and overflowing check for open UFS. See "II.E. Float Switch Check and Cleaning." If UFS is closed, check that WV de-energizes. If not, check CB K2 #8 (O) to a neutral (LBU) for 24VAC. If 24VAC is present, replace CB. If WV de-energizes and water continues to fill the reservoir, replace WV.

Note: Each time UFS closes, 30-min. freeze timer starts. The 30-min. freeze timer resets when UFS closes again. If UFS does not close again within 30 min., CB shuts down the unit and sounds a 5-beep alarm every 5 sec.

See "III.A.2 LED Lights and Audible Alarm Safeties."

FT: 90-Sec. Low Water Safety Timer – When LFS opens, 90-sec. low water safety timer starts. If UFS does not close within 90 sec. after LFS opens (FT exceeded), CB sounds a 1-beep alarm and a 90-sec. shutdown cycle starts. See "III.A.2. LED Lights and Audible Alarm Safeties." Comp de-energizes. GM, CCR, and EH (-C model) continue. 90-sec. purge timer terminates, GM, EH (-C model), and CCR de-energize. WV and 1-beep alarm continue until UFS closes.

11) Drain Cycle

- a) **1-in-1 Drain Cycle:** DV energizes once every hour when the 1-in-1 drain cycle is activated (S1 dip switch 4 in the "OFF" position (factory default position)). GM, FM, Comp continue. DV energizes for 2 sec. every hour. This setting is recommended for optimum icemaker performance. The 1-in-1 drain cycle allows any sediment to drain from the evaporator without interrupting the icemaking process.
- b) **1-in-12 Drain Cycle (optional):** DV energizes once every 12 hours when the 1-in-12 drain cycle is activated (S1 dip switch 4 in the on position (optional)). 12-hour drain cycle timer terminates, Comp de-energizes. GM, and FM continue. The 5-min. ice purge timer starts. When the 5-min. ice purge timer terminates, GM and FM de-energize. 10-min. DT starts, DV energizes. After 10-min. DT terminates, DV de-energizes icemaking process restarts and 12-hour drain cycle timer starts.
- c) **Manual Drain:** Manual drain is used when servicing evaporator components and cleaning and sanitizing the unit. When the unit is making ice and the control switch is moved to the "DRAIN" position, there is a 3-sec. delay, then Comp de-energizes and the 5-min. ice purge timer begins. When the 5-min. ice purge timer terminates, GM and FM de-energize. DV energizes to drain the evaporator and reservoir. To avoid the 5-min. shutdown delay, turn off the power supply, then move the control switch to the "DRAIN" position. Turn on the power supply. DV energizes to drain the evaporator and reservoir. DV de-energizes when the control switch is moved to the "ICE" position.

10) Shutdown

- a) **Auxiliary Code: E-0:** Bin fills with ice activating BC proximity switch. BC opens (actuator paddle engaged). CB shuts down the icemaker within 10 sec.

Auxiliary Code: F-0 and Later: Bin fills with ice activating BC proximity switch. CB starts 90-sec. Comp shutdown timer. Once 90-sec. Comp shutdown timer terminates, Comp and FM de-energize and 60-sec. GM shutdown timer starts. Once 60-sec. GM shutdown timer terminates, GM de-energizes and icemaker is off.

Shutdown Diagnosis: Check that BC actuator paddle is activated and not sticking. Check BC proximity switch continuity. When BC actuator paddle is down (icemaking), BC proximity switch is closed. When BC actuator paddle is up BC proximity switch is open. If not, replace BC proximity switch. If BC proximity switch is open and Comp, FM, and GM do not de-energize, replace CB. See "II.C. Control Board Check Procedure."

Note: Dip Switch 9 becomes active with aux. code F-0 and later. This allows for management between fast shutdown and slow shutdown. Default setting for F-0 and later is for slow shutdown Dip Switch 9 "OFF" position. Dip switch 9 can be moved to the "ON" position for fast-timing (shutdown within 6 to 10 sec.).

Legend: **BC**—bin control; **CB**—control board; **CCR**—compressor control relay;
Comp—compressor; **DV**—drain valve; **EH**—evaporator heater (-C model);
FM—fan motor; **GM**—gear motor; **GMR**—gear motor relay; **LFS**—lower float switch;
UFS—upper float switch; **WV**—inlet water valve

C. Control Board Check

Before replacing a control board that does not show a visible defect and that you suspect is bad, always conduct the following check procedure. This procedure will help you verify your diagnosis.

- 1) Check CB S1 dip switch settings to assure that they are in the factory default position. For factory default settings, see "III.B.1. Default Dip Switch Settings."

Note: S1 dip switch 7 determines bin control application:

BC: S1 dip switch 7 in the "OFF" position.

- 2) Move the power switch to the "ON" position and move the control switch to the "ICE" position. The "POWER OK" LED turns on. **Diagnosis "POWER OK" LED:** Check that the CB "POWER OK" LED is on. If not, check for proper supply voltage (115VAC) input to the control transformer (power switch, power supply cord, breaker, and fuse). Next, check for proper low-voltage (24VAC) output from the control transformer and that the 3A fuse is good. Check for 24VAC at CB K8 #1 (W/R) to CB K8 #2 (LBU). If 24VAC is present and the "POWER OK" LED is off, replace CB.

3) 5VDC Output Checks:

CB K9 Connector: Control Switch (CB K9 #1 and #2) (open contacts for icemaking, closed contacts for drain), High-Pressure Switch (CB K9 #3 and #4), Compressor Control Relay (K9 #5 and #6).

CB K8 Connector: Bin Control (K8 #3 and #4) and Float Switch (K8 #5 (common), #6 (lower), and #7 (upper)).

When checking 5VDC control voltage, always place the red positive test lead from the multimeter to the CB white K5 pin closest to the CB red K4 connector. See Fig. 1. Then place the black negative test lead from the multimeter to the corresponding pin to complete the 5VDC check.

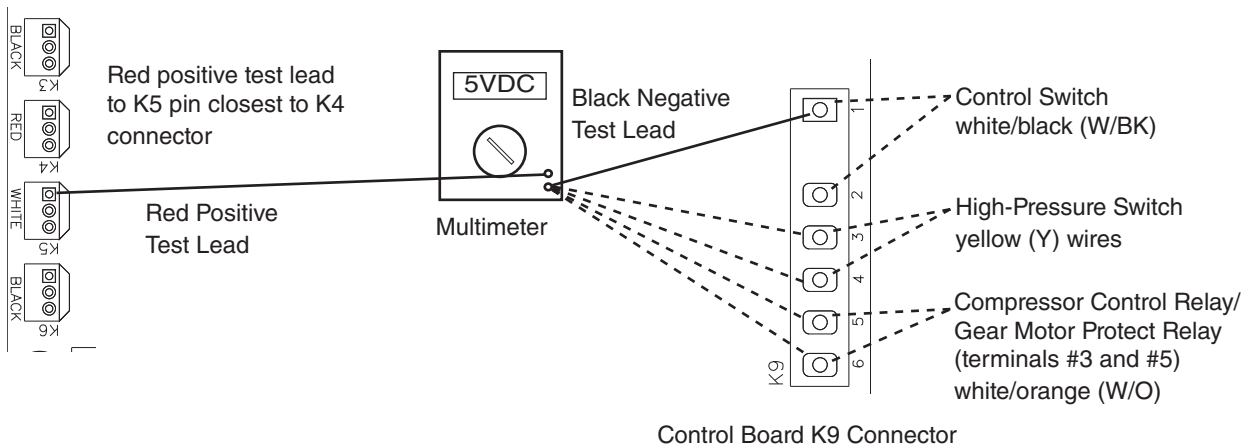

Fig. 1

- a) **Control Switch** – CB K9 #1 (W/BK) and CB K9 #2 (W/BK): 5VDC is present between CB white K5 connector, pin closest to CB red K4 connector and CB K9 #1 (W/BK) at all times. If 5VDC is not present, replace CB. When the control switch is in the "ICE" position, the control switch contacts are open. 0VDC is present between CB white K5 connector, pin closest to CB red K4 connector and CB K9 #2 (W/BK). When in the "ICE" position, 5VDC is present between CB K9 #1 (W/BK) to CB K9 #2 (W/BK). When the control switch is in the "DRAIN" position, the control switch contacts are closed. 5VDC is present between CB white K5 connector, pin closest to CB red K4 connector, to CB K9 #1 (W/BK) or #2 (W/BK). If 5VDC is not present, replace CB. 0VDC is present from CB K9 #1 (W/BK) to CB K9 #2 (W/BK).
- b) **High-Pressure Switch** – CB K9 #3 (Y) and CB K9 #4 (Y): 5VDC is present between CB K5 connector, pin closest to CB red K4 connector and CB K9 #3 (Y) at all times. When the high-pressure switch is closed, 5VDC is present between CB K5 pin closest to CB K4 connector to CB K9 #3 (Y) and CB K9 #4 (Y). If 5VDC is not present, replace CB. When the high-pressure switch is closed, 0VDC is present at CB K9 #3 (Y) to CB K9 #4 (Y). When the high-pressure switch is open, 5VDC is present at CB K9 #3 (Y) to CB K9 #4 (Y). If the high-pressure switch is open and CB is not in alarm, replace CB. If 5VDC is present at CB K9 #3 (Y) and not at CB K9 #4 (Y), the high-pressure switch is open and CB sounds a 3-beep alarm. Check continuity across the high-pressure switch (CB K9 #3 (Y) and CB K9 #4 (Y)).
- c) **Compressor Control Relay (CCR)** – CB K9 #5 (W/O) and CB K9 #6 (W/O): 5VDC is present from CB white K5 connector, pin closest to CB red K4 connector to CB K9 #5 (W/O) at all times. If 5VDC is not present, replace CB. When CCR terminals #3 (W/O) and #4 (W/O) are open (CCR de-energized), 5VDC is present between CB K9 #5 (W/O) and CB K9 #6 (W/O). When CCR terminals #3 (W/O) and #4 (W/O) are closed (CCR energized), 5VDC is present between CB K9 #5 (W/O) and CB K9 #6 (W/O). When CCR terminals #3 (W/O) & #5 (W/O) are open CB may be in an 8-beep alarm. See "III.A.2. LED Lights and Audible Alarm Safeties."
- d) **Bin Control** – CB K8 #3 (GY) and CB K8 #4 (GY): 5VDC is present from CB white K5 connector, pin closest to CB red K4 connector to CB K8 #3 (GY) at all times. If 5VDC is not present, replace CB. When BC is closed (calling for ice), 5VDC is present from CB white K5 connector, pin closest to CB red K4 connector, to CB K8 #3 (GY) and CB K8 #4 (GY). If 5VDC is not present to either CB K8 #3 (GY) or CB K8 #4 (GY), replace CB. If 5VDC is present at CB K8 #3 (GY) and not to CB K8 #4 (GY), BC is open. See "II.D. Bin Control Check."
- e) **Float Switch (LFS and UFS)** – CB K8 #5 (BK) (common), CB K8 #6 (R) (upper), and CB K8 #7 (BU) (lower): 5VDC is present from CB white K5 connector pin closest to CB red K4 connector to CB K8 #5 (BK) (common) at all times. If not, replace CB. 5VDC is present from CB white K5 connector pin closest to CB red K4 connector to CB K8 #6 (R) (upper) and CB K8 #7 (BU) (lower) when FS is open. If 5VDC is present between CB K8 #5 (BK) and CB K8 #6 (R) (upper) or CB K8 #7 (BU) (lower), FS is open. For further FS diagnostics, see "II.E. Float Switch Check and Cleaning."

- 5) **Fill "WTRIN" LED is on:** 24VAC is present at CB K2 #9 (W/R) at all times. If not, confirm 24VAC from CB K2 #9 (W/R) to a neutral (LBU). When LFS open at startup or opens during normal operation, "WTRIN" LED turns on, fill timer (FT) starts, freeze timer (FZT) terminates (only during normal operation), and WV energizes. If LFS is open and "WTRIN" LED is off, confirm LFS status. See "II.E. Float Switch Check and Cleaning." If LFS is open and "WTRIN" LED is off, replace CB. If "WTRIN" LED is on and WV is not energized, check for 24VAC at CB K2 #8 (O) to a neutral (LBU). If 24VAC is not present at CB K2 #8 (O), replace CB. "WTRIN" LED turns off once UFS closes. If not, confirm UFS status. See "II.E. Float Switch Check and Cleaning." If UFS is closed and "WTRIN" LED is on, replace CB. If "WTRIN" LED is off and WV is open, check for 24VAC at CB K2 #8 (O). If 24VAC is present at CB K2 #8 (O), replace CB. If 24VAC is not present, check WV diaphragm.
- 6) **Ice Purge Cycle "GM" LED is on:** When UFS closes, GM delay timer starts (5 or 30 sec. depending on CB S1 dip switch #7). Once GM delay timer terminates, "GM" LED turns on, GM and EH (-C model) energize and 5-min. ice purge timer starts. If GM does not energize 5 sec. after UFS closes, confirm UFS status. See "II.E. Float Switch Check and Cleaning." If UFS is closed and GM LED does not turn, replace CB. If "GM" LED is on and GM and EH (-C model) are off, check for 115VAC from CB K1 #2 (BK) to a neutral (W). If 115VAC is not present, check 115VAC power supply connections from power switch. If 115VAC is present, check for 115VAC from CB K1 #3 (P) to a neutral (W). If 115VAC is present on CB K1 #2 (BK) and not on CB K1 #3 (P), replace CB.
- 7) **Freeze Cycle "GM" and "COMP" LED are on:** The 5-min. ice purge timer terminates or the ice purge cycle bypass button ("SERVICE") is pressed, "COMP" LED turns on. To bypass the 5-min. Ice Purge Cycle, press the "SERVICE" button on CB after the "GM" LED turns on. **WARNING! Risk of electric shock. Care should be taken not to touch live terminals.** 115VAC is present between CB X1 relay power supply black (BK) wire and neutral (W) at all times. If not, check 115VAC power supply wire connections from power switch. If "COMP" LED is not on after 5-min. ice purge timer terminates, replace CB. When "COMP" LED turns on, CR and Comp energize. If "COMP" LED is on and compressor relay (CR) and Comp are not, check for 115VAC from CB X1 relay power supply black (BK) wire to neutral (W). If 115VAC is present, check X1 relay violet (V) wire to neutral (W). If 115VAC is present on X1 relay black (BK) and not on X1 relay violet (V), replace CB.
- 8) **Refill "WTRIN" LED is on:** See "5) Fill "WTRIN" LED is on:" above.
- 9) **Shutdown:** See "I.C.3)D) Bin Control" above.

Legend: **BC**—bin control; **CB**—control board; **Comp**—compressor; **CR**—compressor relay; **CCR**—compressor control relay; **EH**—evaporator heater (-C model); **FS**—float switch; **GM**—gear motor; **LFS**—lower float switch; **UFS**—upper float switch; **WV**—inlet water valve

Control Board Shown

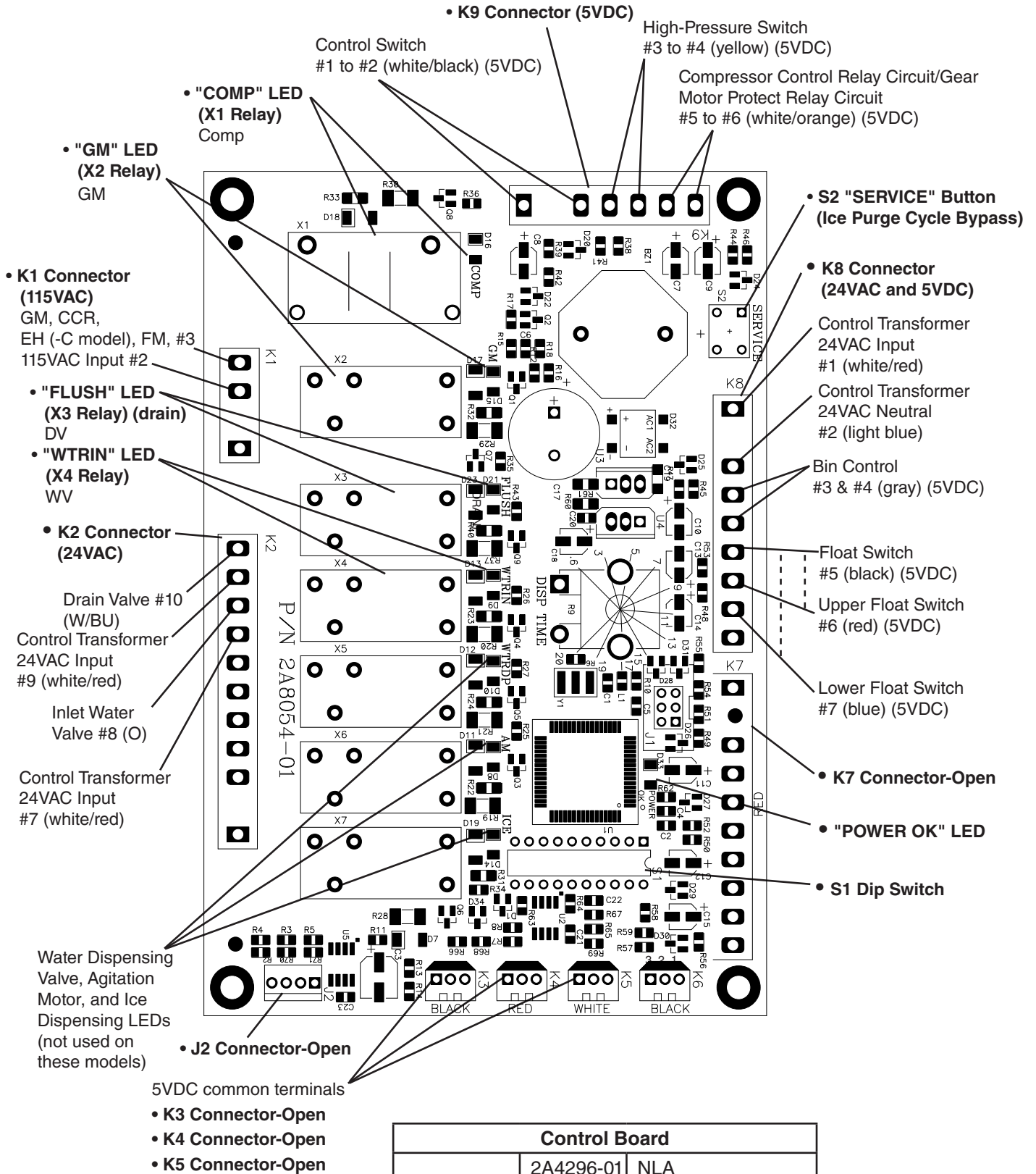

Control Board		
Part Number	2A4296-01	NLA
	2A8054-01	Replacement for all

D. Bin Control Check

Bin Control Check

When the actuator paddle is not engaged BC is closed and the icemaker produces ice. With CB S1 dip switch 7 placed in the "OFF" position, BC is used as a stand-alone bin control. The stand-alone application should only be used in standard ice storage bin applications. When ice fills the chute and engages the actuator paddle, BC opens and starts CB shutdown sequence.

- 1) Remove the front panel and move the power switch to the "OFF" position, then unplug the appliance from the electrical outlet.
- 2) Remove the rear cover. Next remove the 12 pin connector plug from the control box.
- 3) Open the ice storage bin door so that you can access the actuator paddle located in the top of the bin. See Fig. 2.

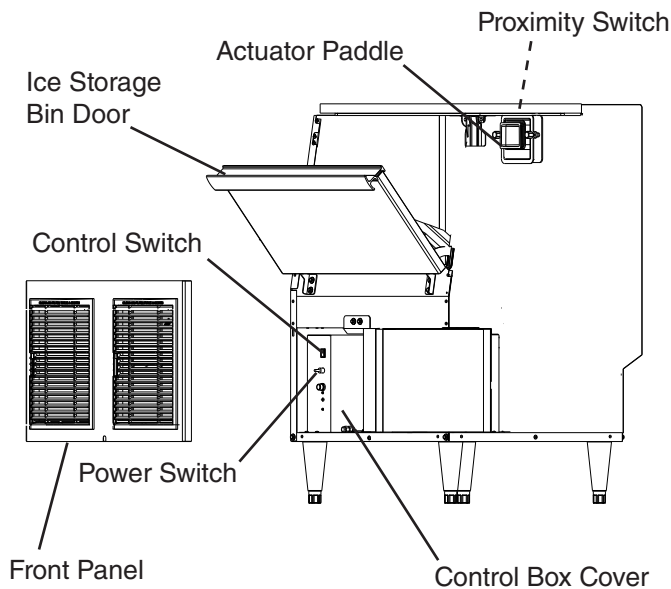

Fig. 2

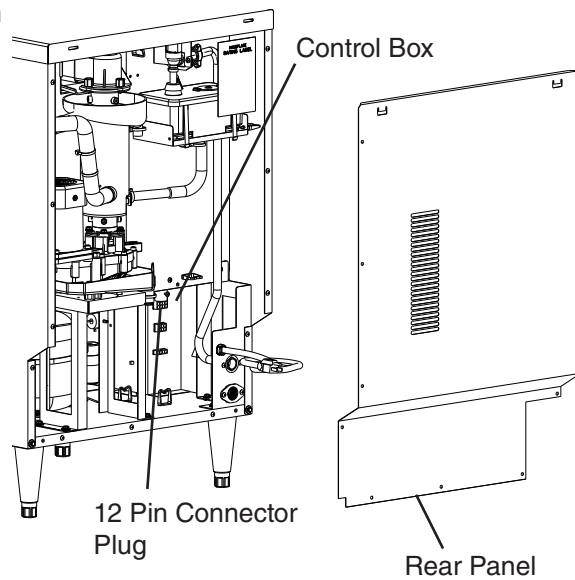

Fig. 3

- 4) With actuator paddle not engaged, check for continuity across BC GY wires (proximity switch) in 12 pin connector plug. BC closed. If BC continuity indicates open BC with the actuator paddle engaged, replace BC (proximity switch).
- 5) Press the actuator paddle located in the top of the bin to the right (actuator paddle engaged). Check for continuity across BC GY wires (proximity switch) in 12 pin connector plug. BC open. If BC continuity indicates closed BC with the actuator paddle engaged, replace BC (proximity switch).
- 6) Reconnect the 12 pin connector plug to the control box.

- 7) Remove the control box anchor screw and swing the control box to the right for control board access. See Fig. 4.

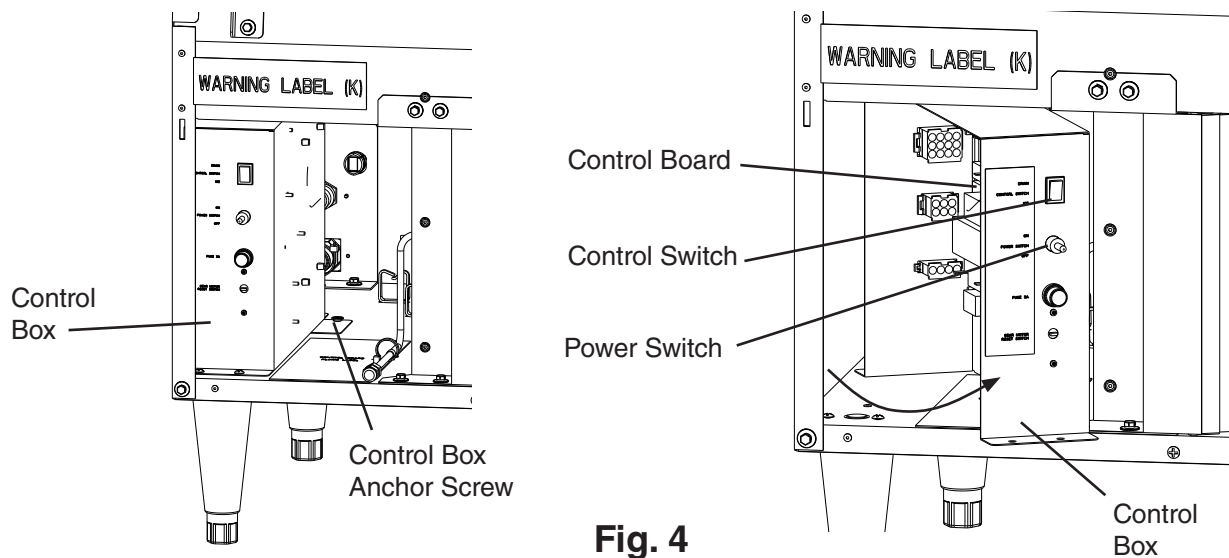

Fig. 4

- 8) Make sure the control switch is in the "ICE" position, then plug the appliance into the electrical outlet and move the power switch to the "ON" position to start the automatic icemaking process.
- 9) Make sure CB "GM" LED is on. There is a delay of at least 5 sec. before "GM" LED turns on after power-up. After "GM" LED turns on, press CB "SERVICE" button to bypass the 5-min. compressor delay. **WARNING! Risk of electric shock. Care should be taken not to touch live terminals.** The "COMP" LED turns on.
- 10) Press the actuator paddle located in the top of the bin toward the front of the appliance. See Fig. 2.
Auxiliary Code E-0: Comp and GM de-energize within 10 sec.
Diagnosis: If BC does not open or the icemaker continues to make ice, check that the actuator paddle is engaged. If BC proximity switch is found open, replace CB.
Auxiliary Code F-0 and Later: The 90-sec. Comp shutdown timer starts. Once 90-sec. Comp shutdown timer terminates, Comp and FM de-energize and 60-sec. GM shutdown timer starts. Once 60-sec. GM shutdown timer terminates, GM de-energizes.
Diagnosis: If BC proximity switch is found open and the appliance continues to run, replace CB.
- 11) Move the power switch to the "OFF" position, then unplug the appliance from the electrical outlet.
- 12) Replace and secure the control box in its correct position.
- 13) Replace the rear cover in its correct position.
- 14) Move the power switch to the "ON" position, then replace the front panel.
- 15) Close the ice storage bin door.
- 16) Plug the appliance into the electrical outlet to start the automatic icemaking process.

Legend: **BC**—bin control; **CB**—control board; **Comp**—compressor; **FM**—fan motor; **GM**—gear motor

E. Float Switch Check and Cleaning

1. Float Switch Check

A dual float switch is used to determine that there is sufficient water in the reservoir during fill and refill. CB monitors UFS to de-energize WV when UFS closes during fill and refill. CB monitors LFS to energize WV when LFS opens during the freeze cycle (refill). CB monitors the time between LFS opening and UFS closing (90-sec. low water safety). CB also monitors the time between UFS closing and LFS opening (30-min. freeze timer). No adjustment is required.

- 1) Remove the front panel. Next, move the power switch to the "OFF" position, then move the control switch to the "DRAIN" position.
- 2) Move the power switch to the "ON" position to drain the appliance.
- 3) After the water has drained, move the power switch to the "OFF" position and unplug the appliance from the electrical outlet.
- 4) Disconnect the FS moxex plug from the control box and check continuity across FS wires. (BK) to (R) for UFS and (BK) to (BU) for LFS. See Fig. 4. With the water reservoir empty, FS switches are open. If open, continue to step 5. If closed, follow the steps in "II.E.2. Float Switch Cleaning." After cleaning the floats, check them again. Replace if necessary.
- 5) Reconnect the FS moxex plug on the control box.
- 6) Plug the appliance back into the electrical outlet. Next, move the control switch to the "ICE" position, then move the power switch to the "ON" position and let the water reservoir fill.
- 7) Once the reservoir is full and GM starts, move the power switch to the "OFF" position, then unplug the appliance from the electrical outlet.
- 8) Disconnect the FS moxex plug from the control box and check continuity across FS wires. (BK) to (R) for UFS and (BK) to (BU) for LFS. With the water reservoir full, FS switches are closed. If open, follow the steps in "II.E.2. Float Switch Cleaning." After cleaning the floats, check them again. Replace if necessary.
- 9) Reconnect the FS moxex plug on the control box.
- 10) Plug the appliance back into the electrical outlet. Next, move the power switch to the "ON" position to start the automatic icemaking process.
- 11) Replace the front panel in its correct position.

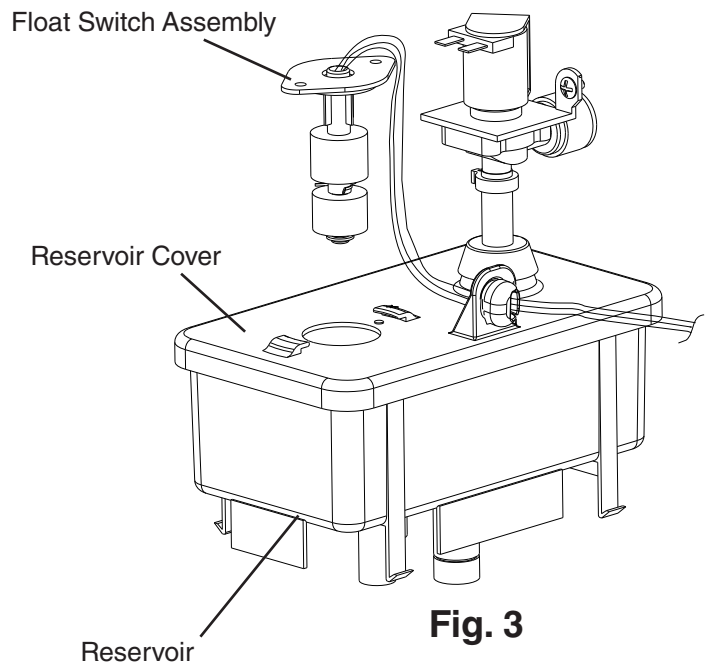

Fig. 3

2. Float Switch Cleaning

Depending on local water conditions, scale may build up on FS. Scale on FS can cause the floats to stick. In this case, FS should be cleaned and checked.

- 1) If not already removed, remove the front panel.
- 2) Move the power switch to the "OFF" position, then unplug the appliance from the electrical outlet.
- 3) Remove the float switch assembly from the reservoir cover. See Fig. 3.
- 4) Wipe down FS assembly with a mixture of 1 part Hoshizaki "Scale Away" and 25 parts warm water.
- 5) While not necessary, the floats can be removed from the shaft during cleaning. If you remove them, note that the blue float is on top. The floats must be installed with the magnets inside them towards the top of the switch. See Fig. 4. Installing the floats upside down will affect the timing of FS operation.
- 6) Rinse FS assembly thoroughly with clean water and replace in its correct position.
- 7) Plug the appliance back into the electrical outlet, confirm the control switch is in the "ICE" position, then move the power switch to the "ON" position to start the automatic icemaking process.
- 8) Replace the front panel in its correct position.

Legend: **CB**—control board; **FS**—float switch; **GM**—gear motor; **LFS**—lower float switch; **UFS**—upper float switch; **WV**—inlet water valve

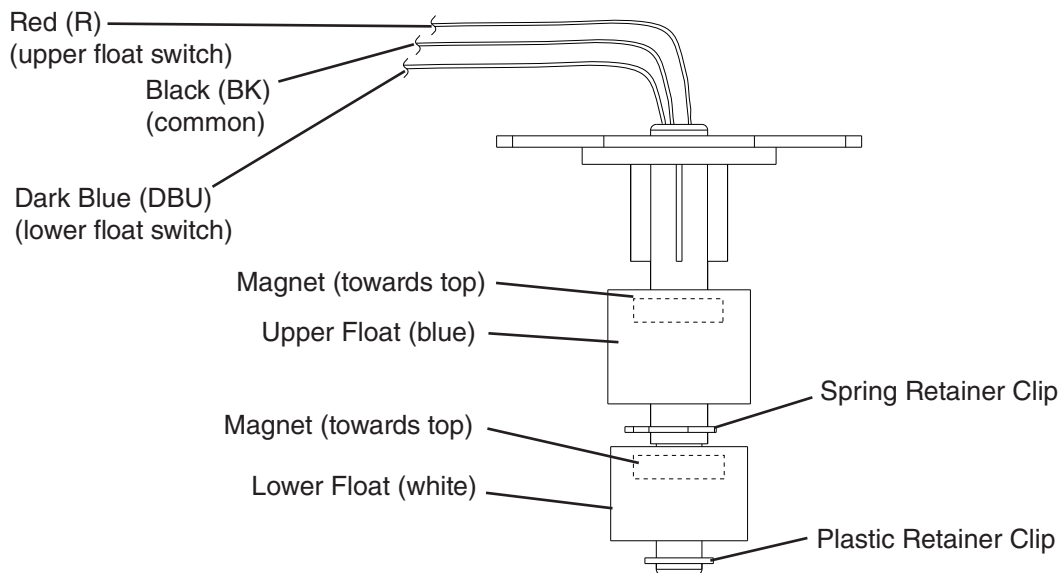

Fig. 4

F. Diagnostic Tables

Before consulting the diagnostic charts, check for correct installation, proper voltage per appliance nameplate, and adequate water supply. Check control board using the steps in "II.C. Control Board Check."

1. No Ice Production

No Ice Production - Possible Cause	
Startup	
1. Power Supply	a) Unplugged, off, blown fuse, or tripped breaker. b) Not within specifications.
2. Water Supply	a) Water supply off or improper water pressure (10 to 113 PSIG). b) External water filters clogged.
3. Power Switch	a) "OFF" position.
4. Control Transformer (115V/24V)	a) Coil winding open or shorted.
5. Fuse (3A)	a) Blown.
6. Bin Control See "II.D. Bin Control Check."	a) Open. b) Defective.
7. Control Switch	a) In "DRAIN" position. b) Defective.
8. Compressor Control Relay	a) Defective.
9. Evaporator Heater (-C model)	a) Defective.
Startup/Fill Cycle (reservoir empty)	
1. Control Board	a) Defective.
2. Inlet Water Valve	a) Screen or orifice clogged. b) Defective.
Startup/Ice Purge Cycle (reservoir full)	
1. Float Switch See "II.E. Float Switch Check and Cleaning."	a) Float does not move freely. b) Defective.
2. High-Pressure Switch	a) Dirty air filter or condenser. b) Condenser fan motor defective. c) Refrigerant overcharge. d) Refrigerant lines or components plugged.
3. Control Board See "II.C. Control Board Check."	a) Defective.
4. Gear Motor	a) External or internal protector open. b) Gear motor winding open. c) Mechanical failure.

No Ice Production - Possible Cause	
Freeze Cycle	
1. Control Board See "II.C. Control Board Check."	a) Defective.
2. Start Relay/Capacitor	a) Defective.
3. Compressor	a) Open motor windings.
	b) Mechanical Failure.
4. Fan Motor	a) Open motor windings.
	b) Mechanical failure or fan blade binding.
5. Evaporator	a) Dirty.
	b) Damaged or defective.
6. Refrigerant Charge	a) Low.
7. Drain Valve	a) Dirty, leaking by.
8. Water System	a) Water leaks.
9. Evaporator Heater (-C model)	a) Defective.
Refill	
1. Float Switch See "II.E. Float Switch Check and Cleaning."	a) Dirty/sticking.
	b) Defective.
2. Inlet Water Valve	a) Screen or orifice clogged.
	b) Defective.
3. Water Supply	a) Water supply off or improper water pressure (10 to 113 PSIG).
	b) External water filters clogged.
4. Control Board See "II.C. Control Board Check."	a) Defective.
Shutdown	
1. Bin Control See "II.D. Bin Control Check."	a) Proximity switch stuck closed.
	b) Actuator paddle does not move freely.
2. Control Board See "II.C. Control Board Check."	a) Defective.
Drain Cycle	
1. Control Board See "II.C. Control Board Check."	a) Defective.
2. Drain Valve	a) Defective.
3. Control Switch	a) Defective.

III. Controls and Adjustments

A. Control Board

- A Hoshizaki exclusive control board is employed.
- All models are pretested and factory adjusted.
- For a control board check procedure, see "II.C. Control Board Check."

<i>NOTICE</i>
<ul style="list-style-type: none">• Fragile, handle very carefully.• The control board contains integrated circuits, which are susceptible to failure due to static discharge. It is especially important to touch the metal part of the icemaker when handling or replacing the control board.• Do not touch the electronic devices on the control board or the back of the control board.• Do not change wiring and connections. Do not misconnect terminals.• Do not short out power supply to test for voltage.• Always replace the whole control board assembly if it goes bad.

1. Control Board Layout Shown:

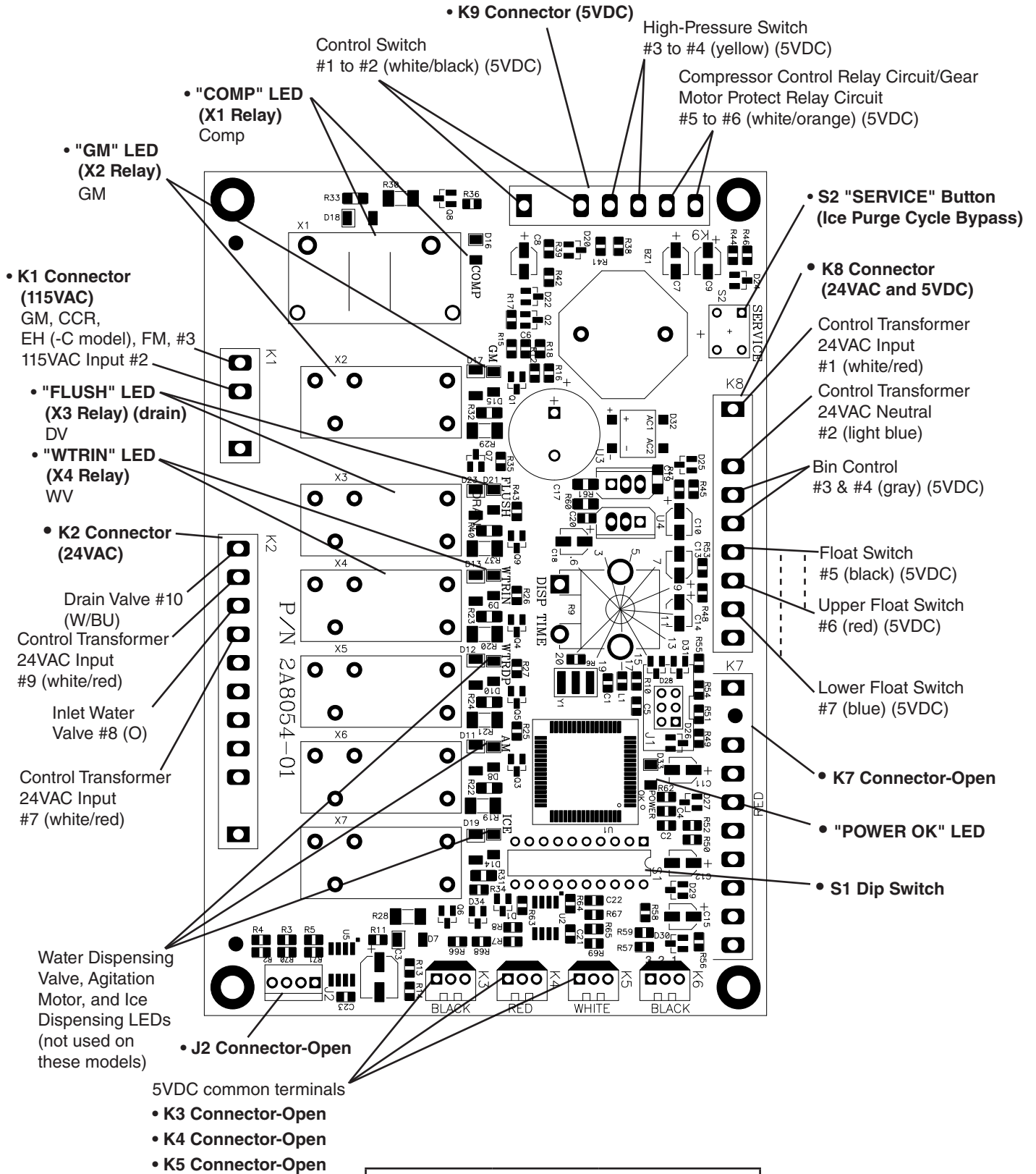

Control Board		
Part Number	2A4296-01	NLA
	2A8054-01	Replace for all

2. LED Lights and Audible Alarm Safeties

The "POWER OK" LED indicates proper control voltage and will remain on unless a control voltage problem occurs. For further details, see "II.A. Sequence of Operation Flow Chart."

Sequence Step	LED	Energized Components	Min.	Max.
Fill Cycle	WTRIN	WV	-	-
Ice Purge Cycle	GM	GM, EH, FM/FMR	5 min.	5 min.
Freeze Cycle (with refill)	GM, WTRIN* (refill), COMP	GM, EH, Comp, FM/FMR, LLV, SLV, WV* (refill)	-	*On until UFS closes. Alarm sounds after 90 sec.
1-in-1 hr or 1-in-12 hr Drain Cycle	FLUSH (Drain)	1-in-1: DV-Icemaker status does not change 1-in-12: DV	2 sec. (1-in-1)	10 min. (1-in-12)

The built-in alarm safeties shut down the unit.

No. of Beeps (every 5 sec.)	Type of Alarm	Reset Options
1	Low-Water Safety UFS open > 90 sec. after WV energized.	Automatic reset once water supply is restored and UFS closes.
2	Control Switch In "DRAIN" position longer than 15 min.	Automatic reset once the control switch is moved to the "ICE" position.
3	High-Pressure Switch First and sec. activation in 1 hour.	Automatic reset once pressure drops below the high pressure threshold and the high pressure switch closes.
4	High-Pressure Switch Third activation in 1 hour.	Call for service. To avoid possible catastrophic failure, it is recommended to leave the icemaker off until this alarm is resolved. Manual reset. Turn power off and on again.
5	Freeze Timer WV off > 30 min. since last WV activation.	Manual reset. Turn power off and on again.
6	Low Voltage (92VAC±5% or less)	"POWER OK" LED turns off if voltage protection operates.
7	High Voltage (147VAC±5% or more)	The control voltage safeties automatically reset when voltage is corrected.
8	Gear Motor CCR contacts fail to close.	Manual reset. Turn power off and on again.
9	Open Circuit CB K8 #3 and #4. (CB S1 dip switch 7 on) Backup MBC engaged or jumper open.	Manual reset. Turn power off and on again.

Legend: **BC**—bin control; **CB**—control board; **CCR**—compressor control relay;
Comp—compressor; **DV**—drain valve; **EH**—evaporator heater; **FM**—fan motor;
FMR—fan motor-remote; **GM**—gear motor; **LLV**—liquid line valve (MLH model only); **MBC**—mechanical backup bin control; **SLV**—suction line valve (MLH model only); **UFS**—upper float switch; **WV**—inlet water valve

3. Ice Purge Cycle Bypass

To speed up the diagnostic process, the 5-min. ice purge cycle may be bypassed by pressing the "SERVICE" button on the control board after the gear motor starts.

WARNING! Risk of electric shock. Care should be taken not to touch live terminals.

B. Controls and Adjustments

NOTICE

Dip switches are factory set. Failure to maintain factory settings may adversely affect performance and warranty coverage. For more information, contact your Hoshizaki Certified Service Representative.

1. Default Dip Switch Settings

The S1 dip switch settings are factory-set to the following positions:

Dip Switch No.	1	2	3	4	5	6	7	8	9	10
F-330BAJ	OFF	OFF	OFF	OFF	OFF	OFF	OFF	ON	OFF	OFF
F-330BAJ-C	OFF	OFF	OFF	OFF	OFF	OFF	OFF	ON	OFF	OFF

Auxiliary Code: E-0

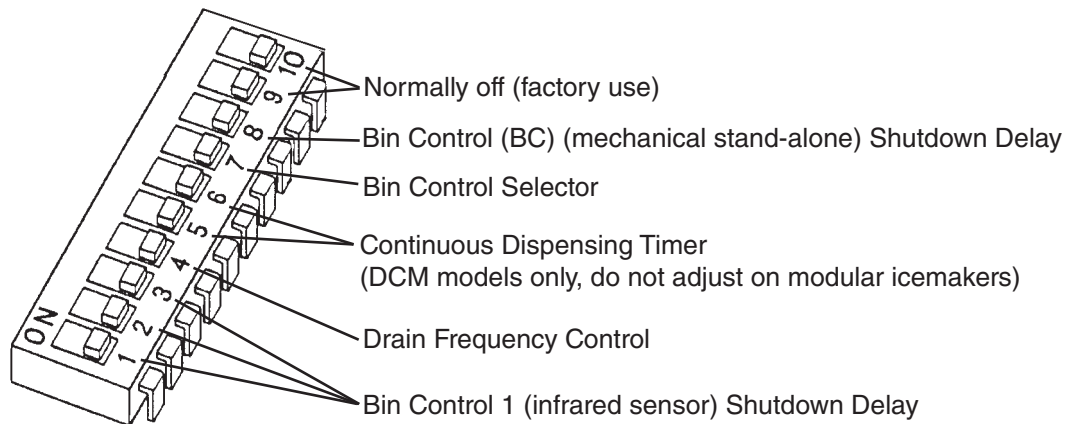

Auxiliary Code: F-0 and Later

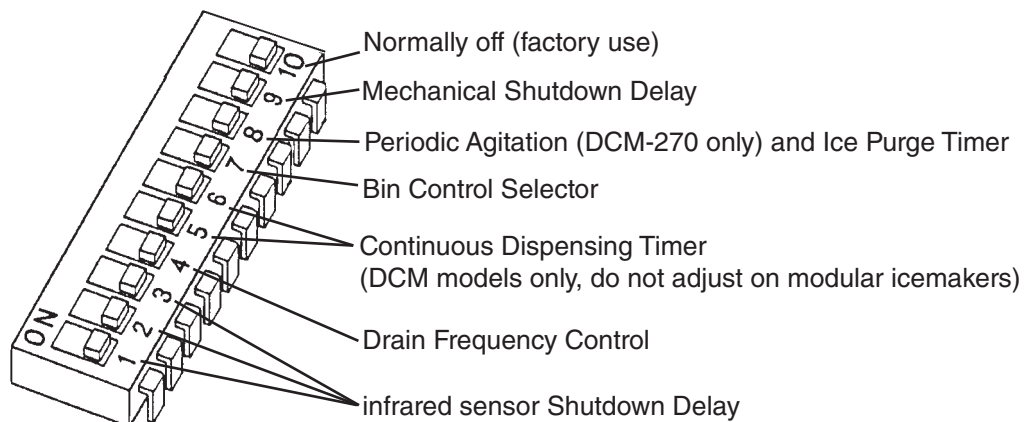

2. Infrared Sensor Shutdown Delay (S1 dip switch 1, 2, 3)

Infrared sensor shutdown delay is the delay between the infrared sensor detecting ice (infrared sensor yellow LED flashing or steady) and the start of the shutdown sequence. For dispenser unit applications, the ice level at shutoff may need to be adjusted depending on the dispenser agitation or dispense method. Increasing the shutdown delay setting allows for a higher level of ice in the bin before the icemaker shuts down. For a typical dispenser unit application, a 100-sec. shutdown delay is recommended. When used with a standard Hoshizaki ice storage bin, any shutdown delay setting is acceptable. **WARNING! Increasing the shutdown delay allows a higher level of ice in the dispenser unit/ice storage bin before shutdown. This could lead to icemaker movement or ice overflow.**

Note: Not Available this Model

S1 Dip Switch Setting			Infrared Sensor Shutdown Delay
No. 1	No. 2	No. 3	
OFF	OFF	OFF	0 Seconds
ON	OFF	OFF	100 Seconds (1.6 minutes) (Factory Default)
OFF	ON	OFF	1100 Seconds (18.3 minutes)
OFF	OFF	ON	1650 Seconds (27.5 minutes)
ON	ON	OFF	2200 Seconds (36.7 minutes)
OFF	ON	ON	0 Seconds
ON	ON	ON	0 Seconds

3. Drain Frequency Control (S1 dip switch 4)

This unit is factory set for optimum performance with the 1-in-1 drain cycle (S1 dip switch 4 in the off position). This setting allows for removal of sediment from the evaporator without interrupting the icemaking process. An optional 1-in-12 drain cycle is available.

S1 Dip Switch Setting	Drain Timer Interval	Drain Valve Open
No. 4		
OFF (1-in-1)	1 Hour	2 Seconds
ON (1-in-12)	11 Hours 45 Minutes	10 Minutes

4. Continuous Dispensing Timer (S1 dip switch 5 & 6)

DCM models only. The dispense mode switch on DCMs must be in the "CONTINUOUS" position for this setting to apply. The factory setting allows ice to be dispensed continuously as long as the dispense solenoid is activated.

Note: Not Available this Model

S1 Dip Switch Setting		Dispense Time
No. 5	No. 6	
OFF	OFF	No Limit
ON	OFF	20 Seconds
OFF	ON	60 Seconds
ON	ON	No Limit

5. Bin Control Selector (S1 dip switch 7)

The bin control selector is factory set. Do not adjust. When used on a standard ice storage bin, only the mechanical bin control should be used. When the mechanical bin control is used (S1 dip switch 7 in the off position), the gear motor delay after the upper float switch closes is 5 sec. **WARNING! Do not place S1 dip switch 7 in the on position on this model. This could lead to no ice operation, control board alarms, or ice overflow.**

S1 Dip Switch Setting	Bin Control Application	Gear Motor Delay
No. 7		
OFF	BC (stand-alone) (Standard Ice Storage Bins Only)	5 seconds
ON	BC1 (infrared sensor) Stand-Alone and BC1 (infrared sensor) with BC2 (mechanical backup)	30 seconds

6a. Mechanical Shutdown Delay (S1 dip switch 8) Auxiliary Code E-0:

Not available when S1 dip switch 7 is on. Factory set for normal operation. No adjustment is required. The shutdown delay is the time between the mechanical bin control proximity switch opening and the control board shutting off the icemaker.

S1 Dip Switch Setting	Shutdown Delay
No. 8	
OFF	No Delay
ON	6 to 10 Seconds

6b. Agitation and Ice Purge Timer (S1 dip switch 8) Auxiliary Code F-0 and Later:

Not available when S1 dip switch 7 is on. Factory set for normal operation. No adjustment is required. **WARNING! Do not adjust S1 dip switch 8 out of the factory default position. This dip switch must be left in the factory default position or the appliance will not operate correctly.**

S1 Dip Switch Setting	Storage Bin Periodic Agitation	Ice Purge Timer
No. 8		
OFF	2 Seconds	60 Seconds (1 min.)
ON	No Agitation	300 Seconds (5 min.)

7. Mechanical Shutdown Delay (S1 dip switch 9) Auxiliary Code F-0 and Later

The shutdown delay is the time between the bin control micro-switch opening and the control board shutting down the appliance. **WARNING! Do not adjust S1 dip switch 9 out of the factory default position. This dip switch must be left in the factory default position or the appliance will not operate correctly.**

S1 Dip Switch Setting	Mechanical Shutdown Delay
No. 9	
OFF	90-60 Second Sequence (150 sec. total)
ON	6 to 10 Seconds

8a. Factory Use (S1 Dip Switch 9 & 10) Auxiliary Code E-0

Factory set for optimum performance. Do not adjust.

8b. Factory Use (S1 Dip Switch 10) Auxiliary Code F-0 and Later

Factory set for optimum performance. Do not adjust.

C. Power Switch and Control Switch

The power switch and the control switch are used to control the icemaker. They are located on the control box.

1. Power Switch

The power switch has 2 positions, "OFF" and "ON." When the power switch is in the "OFF" position, no power is supplied to the components. When in the "ON" position, power is supplied to the control transformer and control board. The control board then supplies 5VDC to the control switch for unit operation.

2. Control Switch

The control switch has 2 positions, "ICE" and "DRAIN."

When the control switch is in the "ICE" position (open), icemaking begins.

When the control switch is in the "DRAIN" position (closed), the drain valve energizes.

a) ICE

When the control switch is in the "ICE" position, the control board reads an open circuit through the control switch contacts and starts the icemaking process.

b) DRAIN

When the control switch is in the "DRAIN" position, the control board reads a closed circuit through the control switch and the drain valve energizes.

IV. Refrigeration Circuit and Component Service Information

⚠ WARNING

- This appliance should be diagnosed and repaired only by qualified service personnel to reduce the risk of death, electric shock, serious injury, or fire.
- Move the power switch to the "OFF" position and turn off the power supply. Place the disconnect in the "OFF" position. Lockout/Tagout to prevent the power supply from being turned back on inadvertently.
- **CHOKING HAZARD:** Ensure all components, fasteners, and thumbscrews are securely in place after the appliance is serviced. Make sure that none have fallen into the dispenser unit/ice storage bin.
- Make sure all food zones in the icemaker and dispenser unit/ice storage bin are clean after service.

A. Refrigeration Circuit Service Information

⚠ WARNING

- Repairs requiring the refrigeration circuit to be opened must be performed by properly trained and EPA-certified service personnel.
- Use an electronic leak detector or soap bubbles to check for leaks. Add a trace of refrigerant to the system (if using an electronic leak detector), and then raise the pressure using nitrogen gas (140 PSIG). Do not use R-404A as a mixture with pressurized air for leak testing.

NOTICE

- Always recover the refrigerant and store it in an approved container. Do not discharge the refrigerant into the atmosphere.
- Do not leave the system open for longer than 15 min. when replacing or servicing parts. The Polyol Ester (POE) oils used in R-404A applications can absorb moisture quickly. Therefore it is important to prevent moisture from entering the system when replacing or servicing parts.
- Always install a new drier every time the sealed refrigeration system is opened. Do not replace the drier until after all other repair or replacement has been made. Install the new drier with the arrow on the drier in the direction of the refrigerant flow.
- When brazing, protect the drier by using a wet cloth to prevent the drier from overheating. Do not allow the drier to exceed 250°F (121°C).

1. Refrigerant Recovery

Using proper refrigerant practices, recover the refrigerant. Recover via the access valves. Store the refrigerant in an approved container. Do not discharge the refrigerant into the atmosphere.

2. Brazing

⚠ WARNING

- R-404A itself is not flammable at atmospheric pressure and temperatures up to 176°F (80°C).
- R-404A itself is not explosive or poisonous. However, when exposed to high temperatures (open flames), R-404A can be decomposed to form hydrofluoric acid and carbonyl fluoride both of which are hazardous.
- Do not use silver alloy or copper alloy containing arsenic.

- 1) Braze all fittings while purging with nitrogen gas flowing at a pressure of 3 to 4 PSIG.

NOTICE

- Always install a new drier every time the sealed refrigeration system is opened.
- Do not replace the drier until after all other repair or replacement has been made. Install the new drier with the arrow on the drier in the direction of the refrigerant flow.
- When brazing, protect the drier by using a wet cloth to prevent the drier from overheating. Do not allow the drier to exceed 250°F (121°C).

- 2) Use an electronic leak detector or soap bubbles to check for leaks. Add a trace of refrigerant to the system (if using an electronic leak detector), and then raise the pressure using nitrogen gas (140 PSIG). Do not use R-404A as a mixture with pressurized air for leak testing.

3. Evacuation and Recharge (R-404A)

- 1) Attach a vacuum pump to the system. Be sure to connect the charging hoses to both high and low-side refrigerant access valves.

IMPORTANT

The vacuum level and vacuum pump may be the same as those for current refrigerants. However, the rubber hose and gauge manifold to be used for evacuation and refrigerant charge should be exclusively for POE oils.

- 2) Turn on the vacuum pump, then open the gauge manifold valves. Never allow the oil in the vacuum pump to flow backwards.
- 3) Allow the vacuum pump to pull down to a 29.9" Hg vacuum. Evacuating period depends on pump capacity.
- 4) Close the low-side valve and high-side valve on the gauge manifold.
- 5) Disconnect the gauge manifold hose from the vacuum pump and attach it to a refrigerant service cylinder. Remember to loosen the connection and purge the air from the hose. For the required refrigerant charge, see the nameplate. Hoshizaki recommends only virgin refrigerant or reclaimed refrigerant which meets ARI Standard 700 (latest edition) be used.

- 6) A liquid charge is required when charging an R-404A system (to prevent fractionation). Place the service cylinder on the scales; if the service cylinder is not equipped with a dip tube, invert the service cylinder, then place it on the scales. Open the high-side valve on the gauge manifold.
- 7) Allow the system to charge with liquid until the proper charge weight is met.
- 8) If necessary, add any remaining charge to the system through the low-side.
NOTICE! To prevent compressor damage, use a throttling valve or liquid dispensing device to add the remaining liquid charge through the low-side refrigerant access valve with the icemaker running.
- 9) Close the high and low-side gauge manifold valves, then disconnect the gauge manifold hoses.
- 10) Cap the refrigerant access valves to prevent a possible leak.

B. Component Service Information

NOTICE

- When replacing a component listed below, see the notes to help ensure proper operation.
- When replacing evaporator assembly and water circuit components, make sure there are no water leaks after the repair is complete.
- Seal bolts must be replaced once removed because seal material is one-time use only. If new seal bolts do not have preapplied threadlocker, apply Loctite 243 or equivalent threadlocker to seal bolt threads. Tighten to the torque values listed below.
Torque for F-330BAJ(-C): 11.1 ft-lb/15 N·m. Tighten 2 times. Allow at least 5 sec. in between each tightening.

Component	Notes
Compressor	<ul style="list-style-type: none"> • Install a new drier, start capacitor, and start relay.
Upper and Lower Bearings	<ul style="list-style-type: none"> • Inspect the upper bearing for wear. See "IV.B.1. Upper Bearing Wear Check." Replace if necessary. • When replacing the upper bearing it is advised to also change the lower bearing at the same time.
Evaporator	<ul style="list-style-type: none"> • Install a new drier. • Inspect the mechanical seal and O-ring prior to installing the new evaporator. If worn, cracked, or scratched, the mechanical seal should also be replaced.
Gear Motor	<ul style="list-style-type: none"> • Install a new gear motor capacitor.

Evaporator Assembly

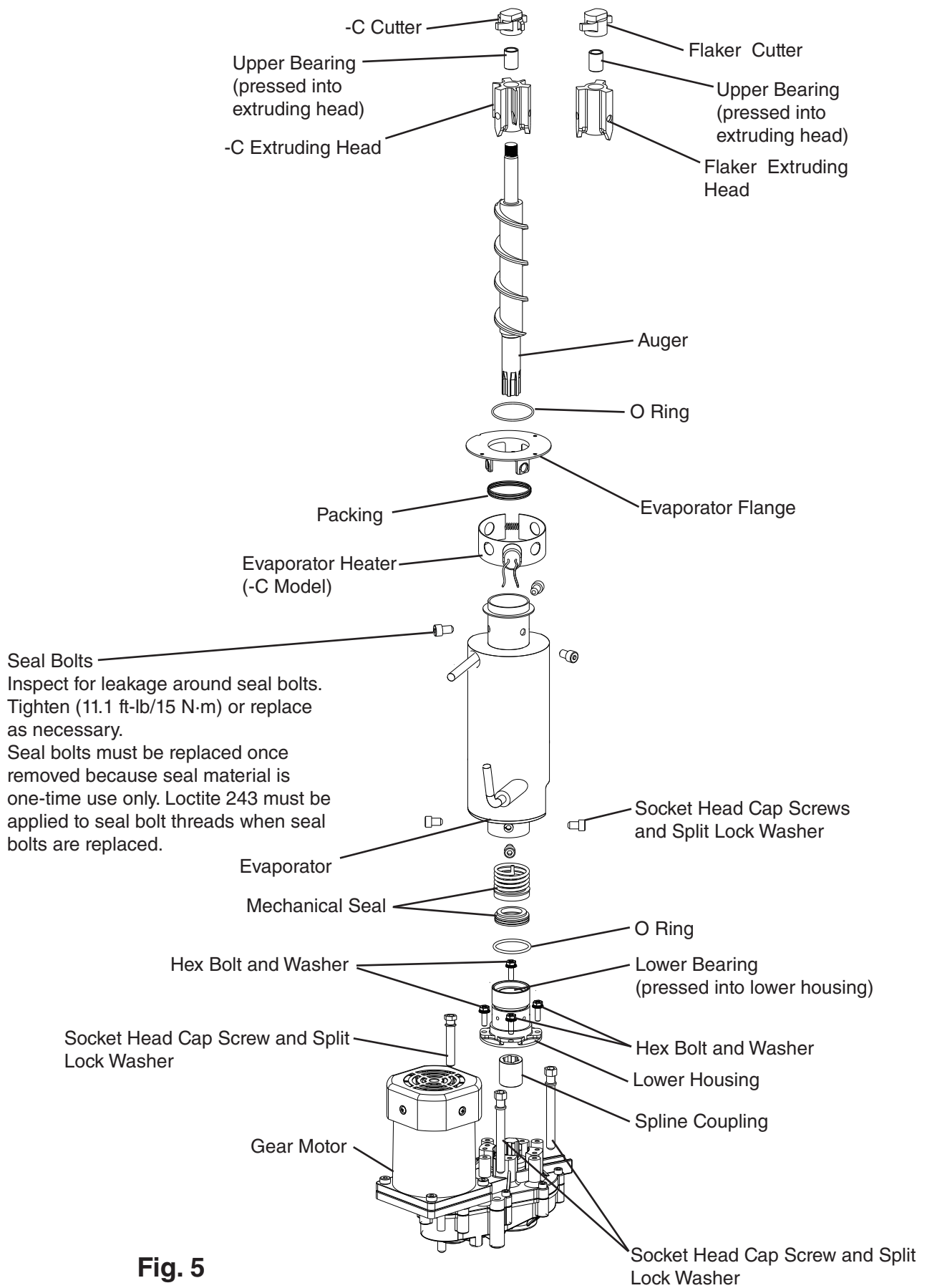

Fig. 5

1. Upper Bearing Wear Check

To ensure that the bearing inside the extruding head does not exceed the wear tolerance of .02", follow the instructions below.

- 1) Remove the front panel. Move the power switch to the "OFF" position, then turn off the power supply.
- 2) Remove the top and side panels.
- 3) Remove the strap connecting the spout to the chute assembly, then remove the spout.
- 4) Remove the bolt (if applicable) or cutter from the auger and lift off the cutter and washer (if applicable).

- 5) Replace the bolt in the auger (if applicable). See Fig. 6. Move the auger towards you and then try to insert a .02" round stock or pin gauge in between the back side of the auger shaft and the bearing surface. Check several locations around the auger shaft. If the gauge goes between the shaft and the bearing at any point or if the bearing is scratched or cracked, both the top bearing in the extruding head and the lower bearing in the housing should be replaced. Instructions for removing the extruding head and housing are located later in this procedure.

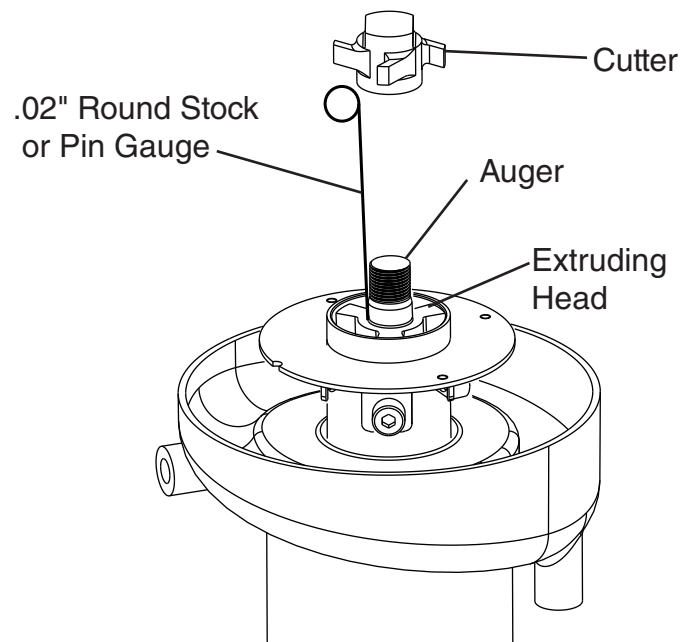

Fig. 6

Note: Replacing the bearing requires a bearing press adaptor. If one is not available, replace the whole extruding head and housing.

- 6) Replace the washer (if applicable), cutter, and cutter bolt (if applicable).
- 7) Replace the spout.
- 8) Replace the top and side panels in their correct positions.
- 9) Move the power switch to the "ON" position, then turn on the power supply.
- 10) Replace the front panel in its correct position.

2. Removal and Replacement of Cutter

- 1) Remove the front panel. Move the power switch to the "OFF" position, then turn off the power supply.
- 2) Remove the top and side panels.
- 3) Remove the strap connecting the spout to the chute assembly, then remove the spout.
- 4) Remove the bolt (if applicable) or cutter and lift off the cutter.
- 5) Install the new cutter. Replace the bolt (if applicable).
- 6) Replace the spout.

- 7) Replace the top and side panels in their correct position.
- 8) Move the power switch to the "ON" position, then turn on the power supply.
- 9) Replace the front panel in its correct position.

IMPORTANT! Seal Bolt Removal and Installation Instructions: Seal bolts must be replaced once removed because seal material is one-time use only. If new seal bolts do not have preapplied threadlocker, apply Loctite 243 or equivalent threadlocker to seal bolt threads.

- Torque for F-330BAJ(-C): 11.1 ft-lb/15 N·m. Tighten 2 times. Allow at least 5 sec. in between each tightening.

3. Removal and Replacement of Extruding Head

- 1) Drain the water from the evaporator.
 - a) Remove the front panel, then move the power switch to the "OFF" position.
 - b) Move the control switch to the "DRAIN" position.
 - c) Move the power switch to the "ON" position and allow the water to drain from the evaporator.
 - d) Move the power switch to the "OFF" position, then turn off the power supply.
- 2) Remove the top and side panels.
- 3) Remove the strap connecting the spout to the chute assembly, then remove the spout.
- 4) Remove the cutter bolt (if applicable) or cutter and lift off the cutter and washer (if applicable).
- 5) Remove the seal bolts from the extruding head and lift off the extruding head.
- 6) Place the new extruding head in place and tighten down with new seal bolts.
See "Seal Bolt Removal and Installation Instructions" above.
- 7) Replace the washer (if applicable), cutter, cutter bolt (if applicable), and spout.
- 8) Replace the top and side panels in their correct positions.
- 9) Move the control switch to the "ICE" position.
- 10) Move the power switch to the "ON" position, then turn on the power supply.
- 11) Replace the front panel in its correct position.

4. Removal and Replacement of Auger

- 1) Drain the water from the evaporator.
 - a) Remove the front panel, then move the power switch to the "OFF" position.
 - b) Move the control switch to the "DRAIN" position.
 - c) Move the power switch to the "ON" position and allow the water to drain from the evaporator.
 - d) Move the power switch to the "OFF" position, then turn off the power supply.
- 2) Remove the top and side panels.
- 3) Remove the strap connecting the spout to the chute assembly, then remove the spout.
- 4) Remove the extruding head seal bolts. Using the cutter, lift out the auger assembly.
- 5) Remove the cutter bolt (if applicable), cutter, washer (if applicable), and dowel pin (if applicable). Remove the extruding head from the auger and place on the new auger.
- 6) Install the new auger.
- 7) Replace the removed parts in the reverse order of which they were removed.
Note: Be sure to use new seal bolts. See "Seal Bolt Removal and Installation Instructions" above.
- 8) Replace the top and side panels in their correct positions.
- 9) Move the control switch to the "ICE" position.
- 10) Move the power switch to the "ON" position, then turn on the power supply.
- 11) Replace the front panel in its correct position.

5. Removal and Replacement of Evaporator

<i>IMPORTANT</i>

Always install a new drier every time the sealed refrigeration system is opened. Do not replace the drier until after all other repair or replacement has been made.

- 1) Drain the water from the evaporator.
 - a) Remove the front panel, then move the power switch to the "OFF" position.
 - b) Move the control switch to the "DRAIN" position.
 - c) Move the power switch to the "ON" position and allow the water to drain from the evaporator.
 - d) Move the power switch to the "OFF" position, then turn off the power supply.
- 2) Remove the top and side panels.
- 3) Recover the refrigerant and store it in an approved container.
- 4) Remove the strap connecting the spout to the chute assembly, then remove the spout.
- 5) Disconnect the water hoses.
- 6) Remove the extruding head seal bolts. Using the cutter, lift out the auger assembly.
- 7) Remove the insulation and the expansion valve bulb on the suction line.
- 8) Disconnect the inlet and outlet tubing.

- 9) Remove the socket head cap screws and split lock washers securing the evaporator to the lower housing.
- 10) Lift off the evaporator.
- 11) Inspect the mechanical seal and O-ring prior to installing the new evaporator. The mechanical seal consists of two parts. One moves along with the auger, and the other is fixed on the lower housing. If the contact surfaces of these two parts are worn, cracked, or scratched, the mechanical seal may cause water leaks and should be replaced. Instructions for removing the mechanical seal and lower housing are located later in this procedure.
- 12) Make sure the lower mechanical seal is in place, then place the evaporator in position. Secure the evaporator to the lower housing using the socket head cap screws and split lock washers.
- 13) Remove the drier, then place the new drier in position.
- 14) Braze all fittings while purging with nitrogen gas flowing at a pressure of 3 to 4 PSIG.
- 15) Use an electronic leak detector or soap bubbles to check for leaks. Add a trace of refrigerant to the system (if using an electronic leak detector), and then raise the pressure using nitrogen gas (140 PSIG). Do not use R-404A as a mixture with pressurized air for leak testing.
- 16) Evacuate the system, and charge it with refrigerant. For air-cooled and water-cooled models, see the nameplate for the required refrigerant charge. For remote models, see the rating label inside the icemaker. Hoshizaki recommends only virgin refrigerant or reclaimed refrigerant which meets AHRI Standard 700 (latest edition) be used.
- 17) Replace the removed parts in the reverse order of which they were removed.
Note: Be sure to use new seal bolts. See "Seal Bolt Removal and Installation Instructions" earlier in this section.
- 18) Replace the top and side panels in their correct positions.
- 19) Move the control switch to the "ICE" position.
- 20) Move the power switch to the "ON" position, then turn on the power supply.
- 21) Replace the front panel in its correct position.

6. Removal and Replacement of Mechanical Seal and Lower Housing

6a. Mechanical Seal

- 1) Drain the water from the evaporator.
 - a) Remove the front panel, then move the power switch to the "OFF" position.
 - b) Move the control switch to the "DRAIN" position.
 - c) Move the power switch to the "ON" position and allow the water to drain from the evaporator.
 - d) Move the power switch to the "OFF" position, then turn off the power supply.
- 2) Remove the top and side panels.
- 3) Remove the strap connecting the spout to the chute assembly, then remove the spout.
- 4) Remove the extruding head seal bolts. Using the cutter, lift out the auger assembly.
- 5) The mechanical seal consists of two parts. One moves along with the auger, and the other is fixed on the lower housing. If the contact surfaces of these two parts are worn, cracked, or scratched, the mechanical seal may cause water leaks and should be replaced.
- 6) Remove the socket head cap screws and split lock washers securing the evaporator to the lower bearing housing.
- 7) Raise the evaporator up to access the lower housing.
- 8) Remove the O-ring and mechanical seal from the housing. If only replacing the mechanical seal, proceed to step 11.

NOTICE
To help prevent water leaks, be careful not to damage the surfaces of the O-ring or mechanical seal.

6b. Lower Housing

- 9) Remove the hex bolts w/washers securing the lower housing to the gear motor and remove the lower housing from the gear motor. If inspection of the upper bearing inside the extruding head (see "IV.B.1. Upper Bearing Wear Check") indicates that it is out of tolerance, replace both it and the bearing inside the lower housing.

Note: Replacing the bearing requires a bearing press adaptor. If one is not available, replace the whole extruding head and lower housing.
- 10) Mount the lower housing on the gear motor.
- 11) Install the O-ring and lower part of the mechanical seal on the lower housing.
- 12) Make sure the lower mechanical seal is in place, then place the evaporator in position. Secure the evaporator to the lower housing using the socket head cap screws and split lock washers.
- 13) Install the auger assembly with the upper part of the mechanical seal attached.
- 14) Replace the removed parts in the reverse order of which they were removed.

Note: Be sure to use new seal bolts. See "Seal Bolt Removal and Installation Instructions" earlier in this section.

- 15) Replace the top and side panels in their correct positions.
- 16) Move the control switch to the "ICE" position.
- 17) Move the power switch to the "ON" position, then turn on the power supply.
- 18) Replace the front panel in its correct position.

7. Removal and Replacement of Gear Motor

- 1) Drain the water from the evaporator.
 - a) Remove the front panel, then move the power switch to the "OFF" position.
 - b) Move the control switch to the "DRAIN" position.
 - c) Move the power switch to the "ON" position and allow the water to drain from the evaporator.
 - d) Move the power switch to the "OFF" position, then turn off the power supply.
- 2) Remove the top and side panels.
- 3) Remove the strap connecting the spout to the chute assembly, then remove the spout.
- 4) Remove the hex head bolts and washers securing the lower housing to the gear motor. Lift the evaporator up slightly.
- 5) Remove the socket head cap screws and split lock washers securing the gear motor.
- 6) Disconnect the gear motor wiring, then remove the gear motor.
- 7) Remove the gear motor bracket and spline coupling from the old gear motor and place on the new gear motor.
- 8) Install the new gear motor and re-connect the electrical wires.
- 9) Replace the removed parts in the reverse order of which they were removed.
- 10) Replace the top and side panels in their correct positions.
- 11) Move the control switch to the "ICE" position.
- 12) Move the power switch to the "ON" position, then turn on the power supply.
- 13) Replace the front panel in its correct position.

V. Maintenance

The appliance must be maintained in accordance with the instruction manual and labels provided. Consult with your local Hoshizaki Certified Service Representative about maintenance service.

WARNING

- Only qualified service technicians should service the appliance.
- To reduce the risk of electric shock, do not touch the icemaker power switch or control switch with damp hands.
- **Before Servicing:** Move the icemaker's power switch to the "OFF" position. Turn off the power supply. Place the disconnect (if applicable) in the off position. Lockout/Tagout to prevent the power supply from being turned back on inadvertently.
- **CHOKING HAZARD:** Ensure all components, fasteners, and thumbscrews are securely in place after any maintenance is done to the appliance. Make sure that none have fallen into the dispenser unit/ice storage bin.

A. Maintenance Schedule

The maintenance schedule below is a guideline. More frequent maintenance may be required depending on water quality, the appliance's environment, and local sanitation regulations.

Maintenance Schedule		
Frequency	Area	Task
Daily	Scoop	Clean the ice scoop using a neutral cleaner. Rinse thoroughly after cleaning.
Bi-Weekly	Air Filters	Inspect. Wash with warm water and neutral cleaner if dirty.
Monthly	External Water Filters	Check for proper pressure and change if necessary.
	Icemaker Exterior	Wipe down with a clean, soft cloth. Use a damp cloth containing a neutral cleaner to wipe off oil or dirt build up. Clean any chlorine staining (rust colored spots) using a non-abrasive cleanser.
Every 6 Months	Icemaker and Ice Storage Bin	Clean and sanitize per the cleaning and sanitizing instructions provided in the instruction manual or on maintenance label.
	Evaporator Condensate Drain Pan and Gear Motor Drain Pan	Wipe down with a clean cloth and warm water. Slowly pour one cup of sanitizing solution (prepare as outlined in the sanitizing instructions provided in the instruction manual) into the evaporator condensate drain pan and then slowly pour one cup into the gear motor drain pan. Be careful not to overflow the pans. Repeat with a cup of clean water to rinse.
	Icemaker and Ice Storage Bin Drains	Check to make sure they are clear.
	Extruding Head Seal Bolts	Inspect for leakage around seal bolts. Tighten (see torque values below) or replace as necessary. Seal bolts must be replaced once removed because seal material is one-time use only. If new seal bolts do not have preapplied threadlocker, apply Loctite 243 or equivalent threadlocker to seal bolt threads. <ul style="list-style-type: none"> • <i>Torque for F-330BAJ(-C):</i> 11.1 ft-lb/15 N-m. Tighten 2 times. Allow at least 5 sec. in between each tightening.
Yearly	Inlet Water Valve and Drain Valve	Close the water supply line shut-off valve and drain the water system. Clean the inlet water valve screen and clean and inspect the drain valve.
	Water Hoses	Inspect the water hoses and clean/replace if necessary.
	Condenser	Inspect. Clean if necessary by using a brush or vacuum cleaner.
	Icemaker	Inspect for oil spots, loose components, fasteners, and wires.
	Upper Bearing (extruding head)	Check for wear using .02" round stock or pin gauge. Replace both upper bearing and lower bearing if wear exceeds factory recommendations.
After 3 Years, then Yearly	Upper Bearing (extruding head); Lower Bearing and O-Ring (lower housing); Mechanical Seal; Evaporator Cylinder; Auger	Inspect. Replace both upper bearing and lower bearing if wear exceeds factory recommendations. Replace the mechanical seal if the seal's contact surfaces are worn, cracked, or scratched.

VI. Disposal

The appliance contains refrigerant and must be disposed of in accordance with applicable national, state, and local codes and regulations. Refrigerant must be recovered by properly certified service personnel.

VII. Technical Information

We reserve the right to make changes in specifications and design without prior notice.

A. Specification & Performance Data Sheets

Note: The data in bold should be used for reference.

1. F-330BAJ

Specification Sheet

AC SUPPLY VOLTAGE	115/60/1	
AMPERES	6.9 AMPS (AT 104°F / WT 80°F)	
ELECTRIC & WATER CONSUMPTION	90/70°F	70/50°F
ELECTRIC W (kWH/100 lbs.)	628 (5.91)	589 (4.24)
POTABLE WATER	29 (12.0)	40 (12.0)
Shape of Ice	Flake	
ICE HARDNESS	80.6% @ (32/21 (90/70), Conductivity 200 µs/cm)	
APPROXIMATE STORAGE CAPACITY	80lbs.	
BIN CONTROL SYSTEM	Mechanical Bin Control (Proximity Sw.)	
REFRIGERANT CHARGE	R404A, 0 lb. 7.1 oz. (200g)	

Performance Data Sheet

APPROXIMATE ICE PRODUCTION PER 24 HR.	Ambient Temp. °F (°C)	Water Temp. °F (°C)		
		50 (10)	70 (21)	90 (32)
	70 (21)	332 (151)	321 (146)	306 (139)
	80 (26)	292 (133)	279 (127)	266 (121)
	90 (32)	254 (115)	243 (110)	231 (105)
lbs./day (kg/day)	100 (38)	221 (100)	210 (95)	198 (90)
APPROXIMATE ELECTRIC CONSUMPTION watts	70 (21)	589 --	594 --	600 --
	80 (26)	605 --	611 --	616 --
	90 (32)	622 --	628 --	633 --
	100 (38)	638 --	642 --	647 --
APPROXIMATE WATER CONSUMPTION PER 24 HR. (TOTAL) gal. / day (l/day)	70 (21)	40 (151)	39 (146)	37 (139)
	80 (26)	35 (133)	33 (127)	32 (121)
	90 (32)	30 (115)	29 (110)	28 (105)
	100 (38)	26 (100)	25 (96)	24 (90)
EVAPORATOR OUTLET TEMP. °F (°C)	70 (21)	21 ((-6))	21 ((-6))	20 ((-6))
	80 (26)	20 ((-7))	20 ((-7))	20 ((-7))
	90 (32)	19 ((-7))	19 ((-7))	19 ((-7))
	100 (38)	18 ((-8))	18 ((-8))	18 ((-8))
HEAD PRESSURE PSIG (kg/cm2G)	70 (21)	212 (14.9)	222 (15.6)	231 (16.3)
	80 (26)	241 (16.9)	251 (17.6)	261 (18.3)
	90 (32)	270 (19.0)	280 (19.7)	290 (20.4)
	100 (38)	300 (21.1)	310 (21.8)	320 (22.5)
SUCTION PRESSURE PSIG (kg/cm2G)	70 (21)	36 (2.5)	37 (2.6)	38 (2.7)
	80 (26)	39 (2.7)	39 (2.8)	40 (2.8)
	90 (32)	41 (2.9)	42 (3.0)	43 (3.0)
	100 (38)	44 (3.1)	44 (3.1)	45 (3.2)
HEAT OF REJECTION FROM CONDENSER	3,400 BTU/h (AT 90°F / WT 70°F)			
HEAT OF REJECTION FROM COMPRESSOR	600 BTU/h (AT 90°F / WT 70°F)			

2. F-330BAJ-C

Specification Sheet

AC SUPPLY VOLTAGE	115/60/1	
AMPERES	7.1 AMPS	
ELECTRIC & WATER CONSUMPTION	90/70°F	70/50°F
ELECTRIC W (kWH/100 lbs.)	654 (7.30)	612 (5.09)
POTABLE WATER	26 (12.0)	35 (12.0)
SHAPE OF ICE	Cubelet	
ICE HARDNESS	88.3% @ (32/21 (90/70), Conductivity 200 µs/cm)	
APPROXIMATE STORAGE CAPACITY	80lbs.	
BIN CONTROL SYSTEM	Mechanical Bin Control (Proximity Sw.)	
REFRIGERANT CHARGE	R404A, 0 lb. 7.1 oz. (200g)	

Performance Data Sheet

APPROXIMATE ICE PRODUCTION PER 24 HR.	Ambient Temp. °F (°C)	Water Temp. °F (°C)		
		50 (10)	70 (21)	90 (32)
	70 (21)	288 (131)	281 (127)	268 (121)
	80 (26)	255 (116)	243 (110)	231 (105)
	90 (32)	220 (100)	214 (97)	200 (91)
lbs./day (kg/day)	100 (38)	190 (86)	181 (82)	167 (76)
APPROXIMATE ELECTRIC CONSUMPTION	70 (21)	612 --	618 --	624 --
	80 (26)	630 --	636 --	642 --
	90 (32)	648 --	654 --	660 --
	100 (38)	665 --	670 --	675 --
APPROXIMATE WATER CONSUMPTION PER 24 HR. (TOTAL) gal. / day (l/day)	70 (21)	35 (131)	34 (128)	32 (122)
	80 (26)	31 (116)	29 (110)	28 (105)
	90 (32)	26 (100)	26 (97)	24 (91)
	100 (38)	23 (87)	22 (82)	20 (76)
EVAPORATOR OUTLET TEMP. °F (°C)	70 (21)	16 ((-9))	16 ((-9))	17 ((-9))
	80 (26)	17 ((-8))	17 ((-8))	18 ((-8))
	90 (32)	18 ((-8))	18 ((-8))	19 ((-7))
	100 (38)	20 ((-7))	21 ((-6))	22 ((-6))
HEAD PRESSURE	70 (21)	212 (14.9)	222 (15.6)	231 (16.3)
	80 (26)	241 (16.9)	251 (17.6)	261 (18.3)
	90 (32)	270 (19.0)	280 (19.7)	290 (20.4)
	100 (38)	300 (21.1)	310 (21.8)	320 (22.5)
SUCTION PRESSURE PSIG (kg/cm2G)	70 (21)	36 (2.5)	37 (2.6)	38 (2.7)
	80 (26)	39 (2.7)	39 (2.8)	40 (2.8)
	90 (32)	41 (2.9)	42 (3.0)	43 (3.0)
	100 (38)	44 (3.1)	44 (3.1)	45 (3.2)
HEAT OF REJECTION FROM CONDENSER	3,400 BTU/h (AT 90°F / WT 70°F)			
HEAT OF REJECTION FROM COMPRESSOR	600 BTU/h (AT 90°F / WT 70°F)			

B. Wiring Diagram

1. F-330BAJ(-C)

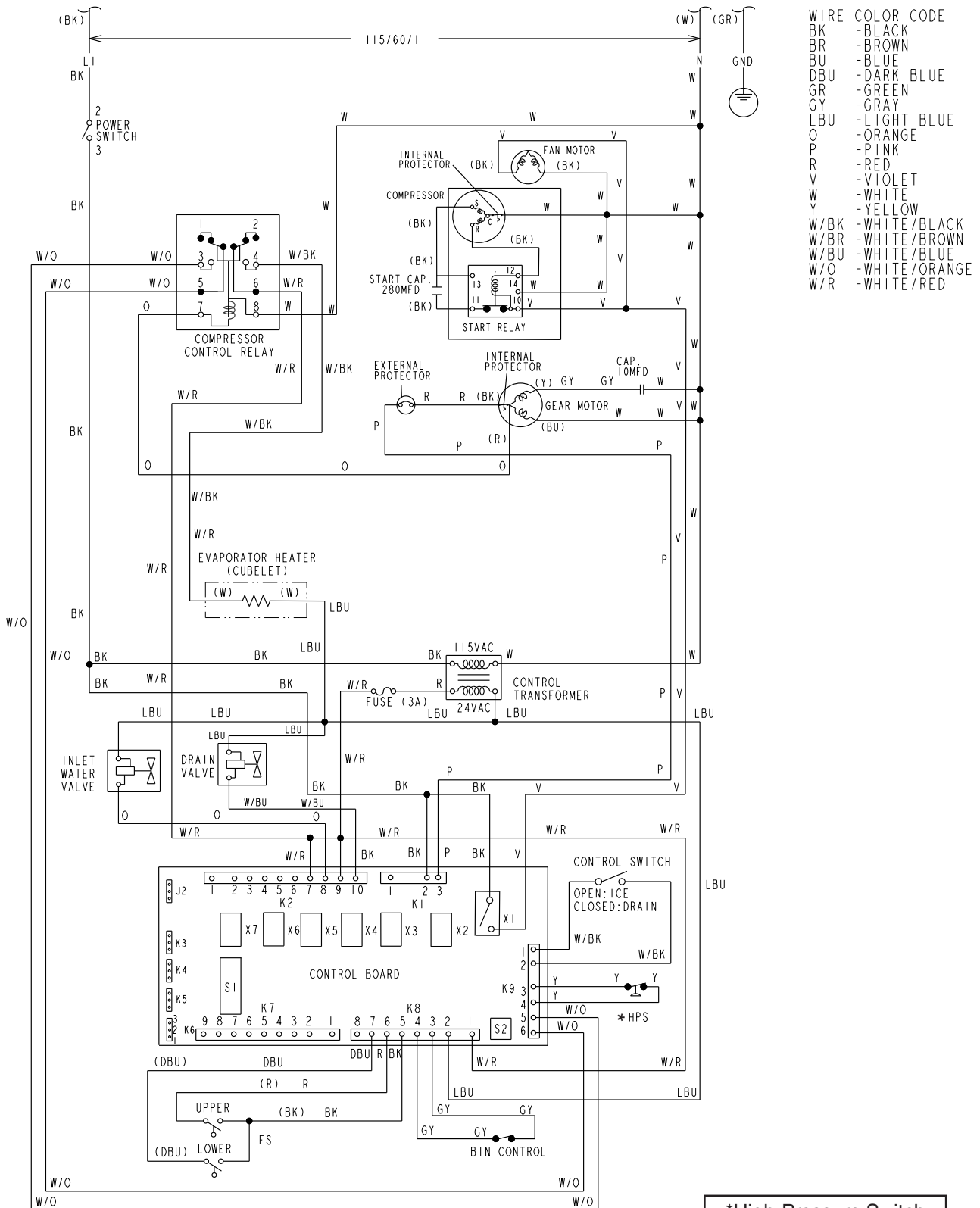

*High-Pressure Switch	
Cut-out	426±22 PSIG
Cut-in	341±22 PSIG

SI DIP SWITCH SETTING	1	2	3	4	5	6	7	8	9	10
F-330BAJ	OFF	OFF	OFF	OFF	OFF	OFF	OFF	ON	OFF	OFF
F-330BAJ-C	OFF	OFF	OFF	OFF	OFF	OFF	OFF	ON	OFF	OFF