



HOSHIZAKI

Parts List

SELF-CONTAINED CUBER

Model
IM-200BAA



hoshizakiamerica.com

Number: M063-4102
Issued: 3-20-2017

Auxiliary Codes

IM-200BAA	E-1	October 2015
IM-200BAA	F-1	April 2016
	G-1	April 2017

Auxiliary Code Breakdown

The auxiliary code is the first two characters in the serial number. The first character indicates the year. Years progress or regress in alphabetical order. The series runs from "A" through "V" and the letters "I" and "O" are skipped. The second character indicates significant part changes within a year. Base is "0" and this number advances for each change. In cases where there is a letter in parentheses, this designates the month. This is the last character in the serial number. The series runs from "(A)" through "(M)" and the letter "(I)" is skipped. This designation is only included when identifying a parts change within an auxiliary code.

Note About Ordering Parts

Most assemblies cannot be ordered as complete units; parts in the assemblies generally must be ordered separately.

MARKS LOCATED UNDER THE AUXILIARY CODE

- = Part deleted.
- x = Part deleted and replaced by "o" part.
- o = New part in place of "x" part.

FASTENER PART NUMBER

SCREWS

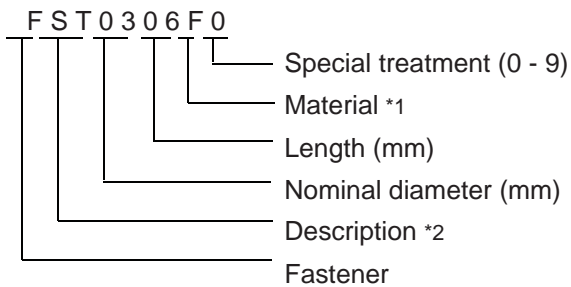

*1

- F: Steel
- S: Austenitic stainless steel
- M: Martensitic stainless steel
- B: Copper alloy
- P: Polycarbonate
- N: Polyamide
- V: PVC
- A: ABS
- X: Polyacetal
- L: Aluminum

NUTS & WASHERS

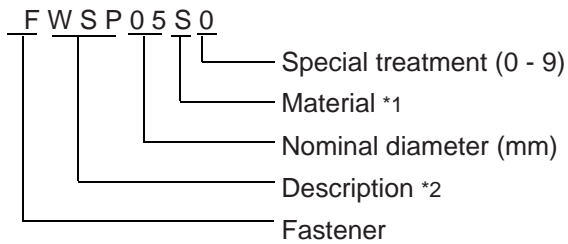

*2

- First letter
- S: Machine screw
- T: Tapping screw
- M: Wood screw
- B: Bolt
- W: Washer
- N: Nut

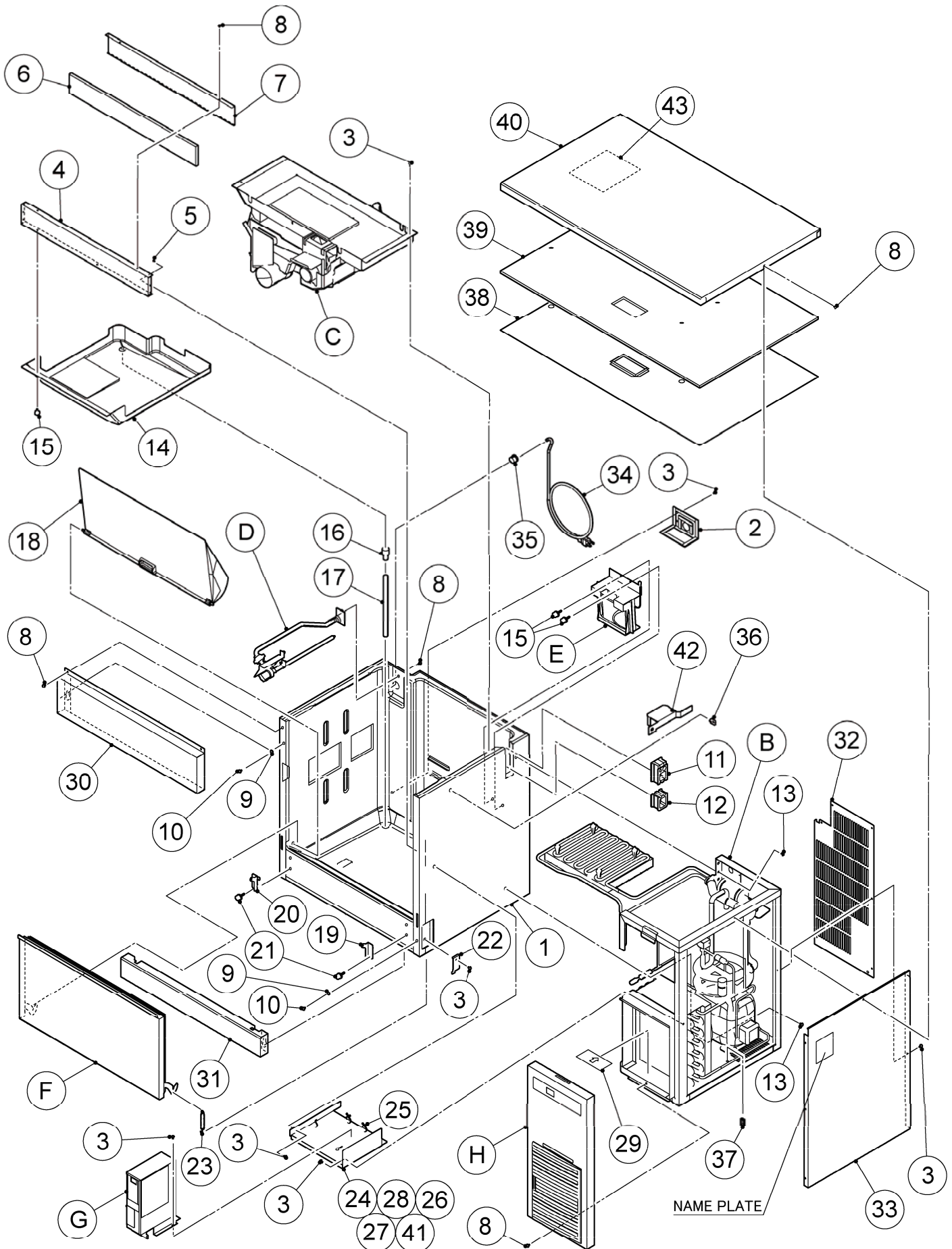

HA

MODEL: IM-200BAA							
TITLE: A. ICE CUBER ASSY							
INDEX NO.	DESCRIPTION	MATERIAL OR MODEL NUMBER	PART NUMBER	REQ'D NUMBER			
				E-1 F-0	F-1 G-0	G-1	
B	REFRIGERATION CIRCUIT		123752A01	1	1	1	
C	MECHANISM ASSY		268084A01	1	1	1	
D	WATER CIRCUIT		268086A01	1	1	1	
E	BIN SW ASSY		381958A01	1	1	1	
F	DOOR ASSY		3Y5436A02	1	1	1	
G	CONTROL BOX ASSY		268088A01	1	1	1	
H	FRONT COVER(R) ASSY		381967A01	1	1	1	
Q	ACCESSORIES		A03107-01	1	1	1	
1	BODY		123760G01	1	1	1	
2	REAR GUIDE		481319G01	1	1	1	
3	Flange Bolt (C-TITE)		FTR0408M0	26	27	27	
4	FRONT FRAME		3Y6326M01	1	1	1	
5	RIVET	SSD42SSBS(t1.6~3.2)	7170-0002	4	4	4	
6	INSULATION-FRONT FRAME		4Y7624P01	1	1	1	
7	FRONT FRAME(B)		381950M01	1	1	1	
8	S-TITE TRUSS HEAD SCREW		FTS0408M0	7	7	7	
9	TAPER COLLAR		4H0171-01	4	4	4	
10	RIVET	SSD42BS	7170-0001	4	4	4	
11	GROMMET(A)		381951R01	1	1	1	
12	GROMMET(B)		381952R01	1	1	1	
13	TAPPING SCREW - HEX		442040-01	4	4	4	
14	DRAIN PAN		2H6143G01	1	1	1	
15	THUMBSCREW		415949G10	4	4	4	
16	DRAIN TUBE		4H2585-01	1	1	1	
17	DRAIN PIPE		4Y7493P03	1	1	1	
18	SLOPE		3H2978G01	1	1	1	
19	HINGE (RIGHT)		4H2583-01	1	1	1	
20	HINGE (LEFT)		4H2584-01	1	1	1	
21	HEX HEAD BOLT (SPRING WASHER AND FLAT WASHER)		FBK0616S0	4	4	4	
22	BRACKET-SPRING		4Y7620M01	1	1	1	
23	SPRING		4X5209-01	1	1	1	
24	PLATE-FRAME		268087M01	1	1	1	
25	WIRE RETAINER		427902-05	3	3	3	

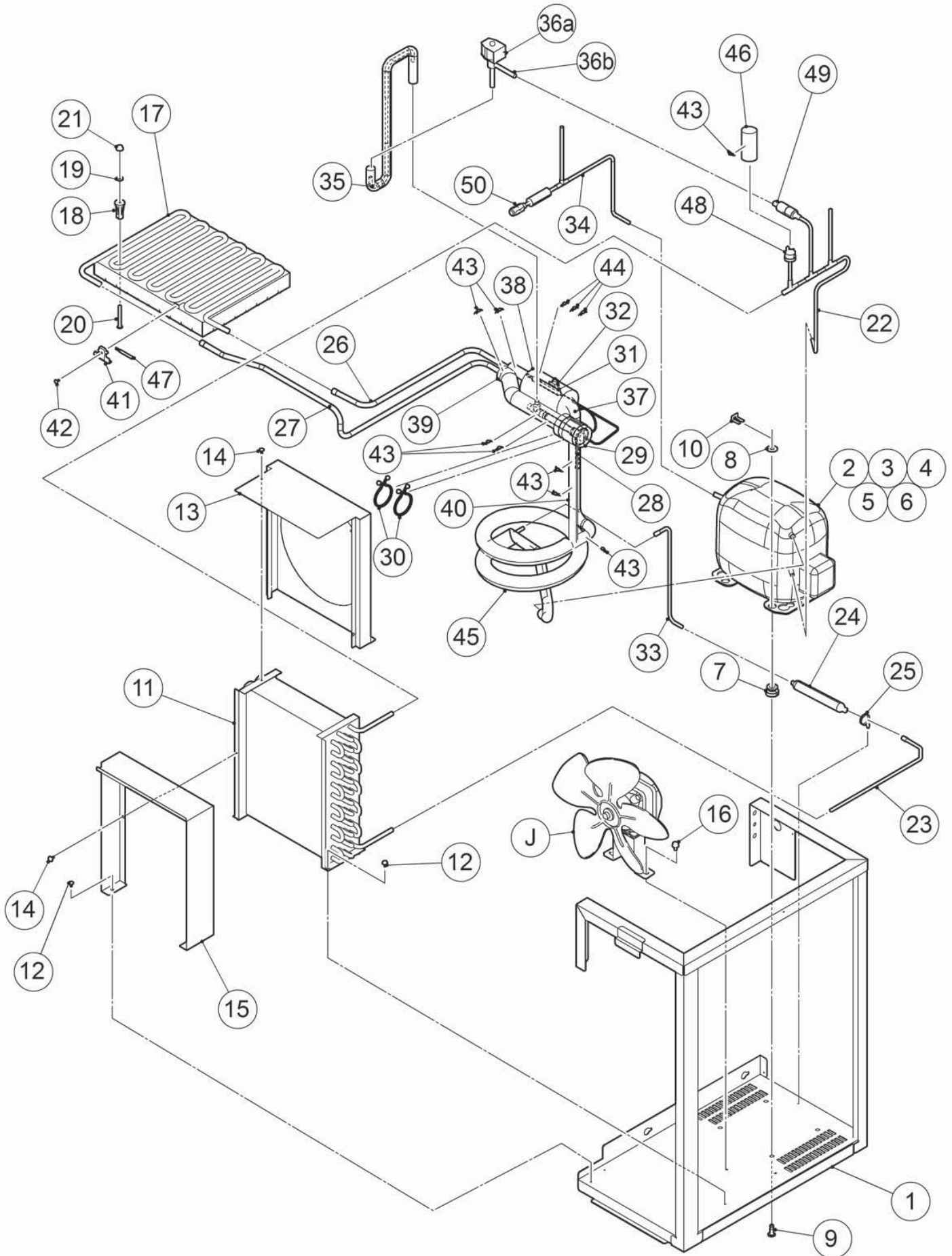

HA

MODEL: IM-200BAA							
TITLE: B. REFRIGERATION ASSY							
INDEX NO.	DESCRIPTION	MATERIAL OR MODEL NUMBER	PART NUMBER	REQ'D NUMBER			
				E-1 F-0	F-1 G-0	G-1	
J	FAN MOTOR ASSY		3Y6055A02	1	1	1	
1	UNIT FRAME G		268038G01	1	1	1	
2	COMPRESSOR	SC15G-104G7550	P03708-01	1	1	1	
3	STARTING RELAY	SC15G ACCESSORIES	P01178-01	1	1	1	
4	COVER	SC15G ACCESSORIES	P01179-01	1	1	1	
5	STARTING CAPACITOR	SC15G ACCESSORIES	P01180-01	1	1	1	
6	CORD RELIEF	SC15G ACCESSORIES	452239-01	1	1	1	
7	GROMMET	SC15G ACCESSORIES	450897-01	4	4	4	
8	WASHER CUSHION	SC15G ACCESSORIES	P02793-01	4	4	4	
9	STEEL PIN	SC15G ACCESSORIES	452255-01	4	4	4	
10	CLIP	SC15G ACCESSORIES	452256-01	4	4	4	
11	CONDENSER	4x12,W230mm,FPI=10	P03374-01	1	1	1	
12	FLANGE BOLT(C-TITE)		FTR0408M0	8	8	8	
13	SHROUD(A)		2X0938M01	1	1	1	
14	T2 TRUSS HEAD SCREW		FT20408F0	6	6	6	
15	SHROUD(B)		3Y6296M01	1	1	1	
16	HEX HEAD BOLT (SPRING WASHER AND FLAT WASHER)		FBK0612S0	2	2	2	
17	EVAPORATOR		2H6438G03	1	1	1	
18	COLLAR		3H3879-01	4	4	4	
19	WASHER		4H0777-01	4	4	4	
20	SCREW-EVAPORATOR		4Y4922M02	4	4	4	
21	FLANGE NUT		FNHF06S0	4	4	4	
22	COPPER TUBE(A)-HIGH SIDE		268042G01	1	1	1	
23	COPPER TUBE(B)-HIGH SIDE		481290M01	1	1	1	
24	DRIER	DY-15QHD-13	458776-01	1	1	1	
25	PUSH MOUNT TIE		436156-01	1	1	1	
26	COPPER TUBE(C)-LOW SIDE		381918M01	1	1	1	
27	COPPER TUBE(D)-LOW SIDE		381919G01	1	1	1	

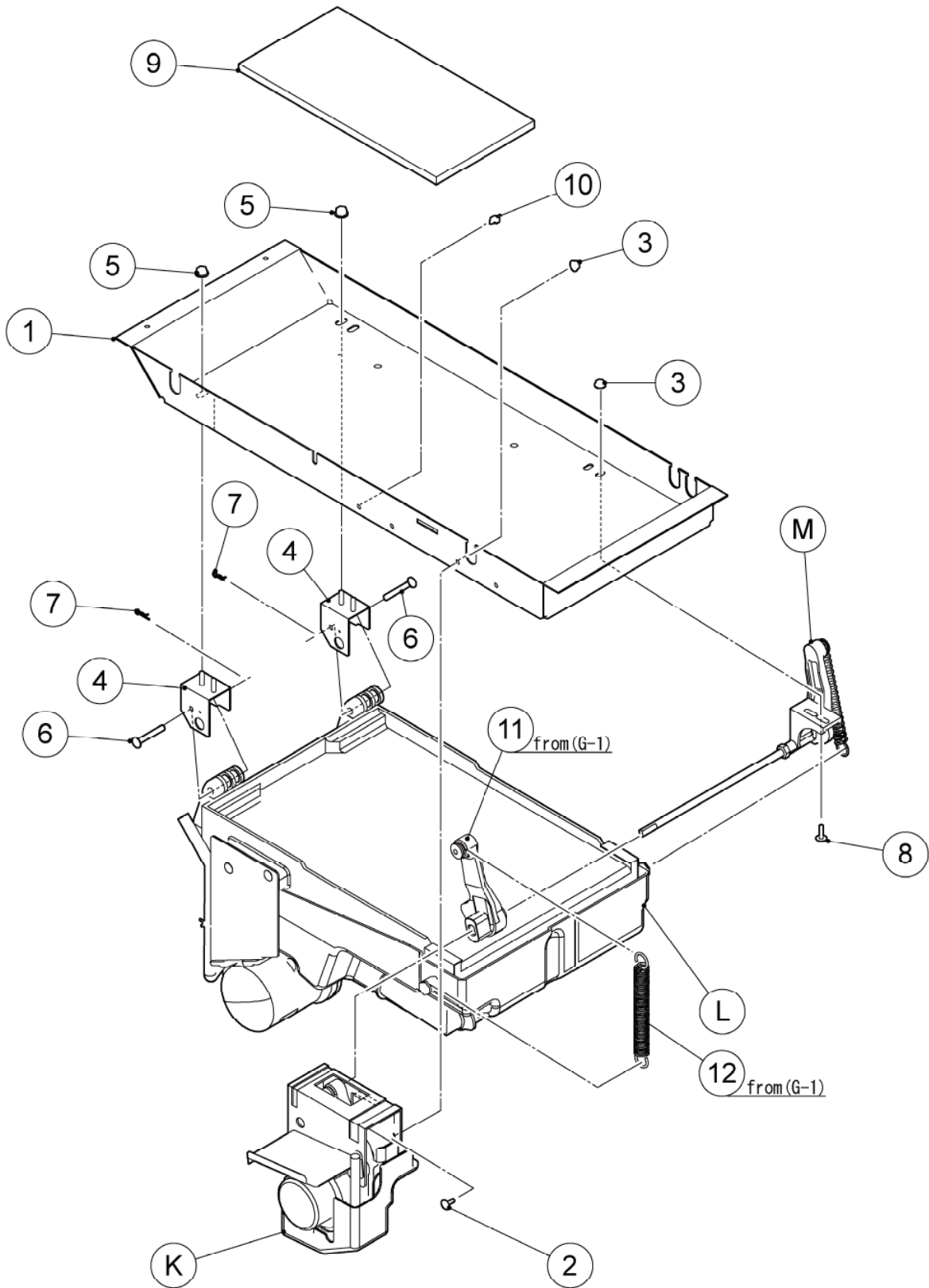

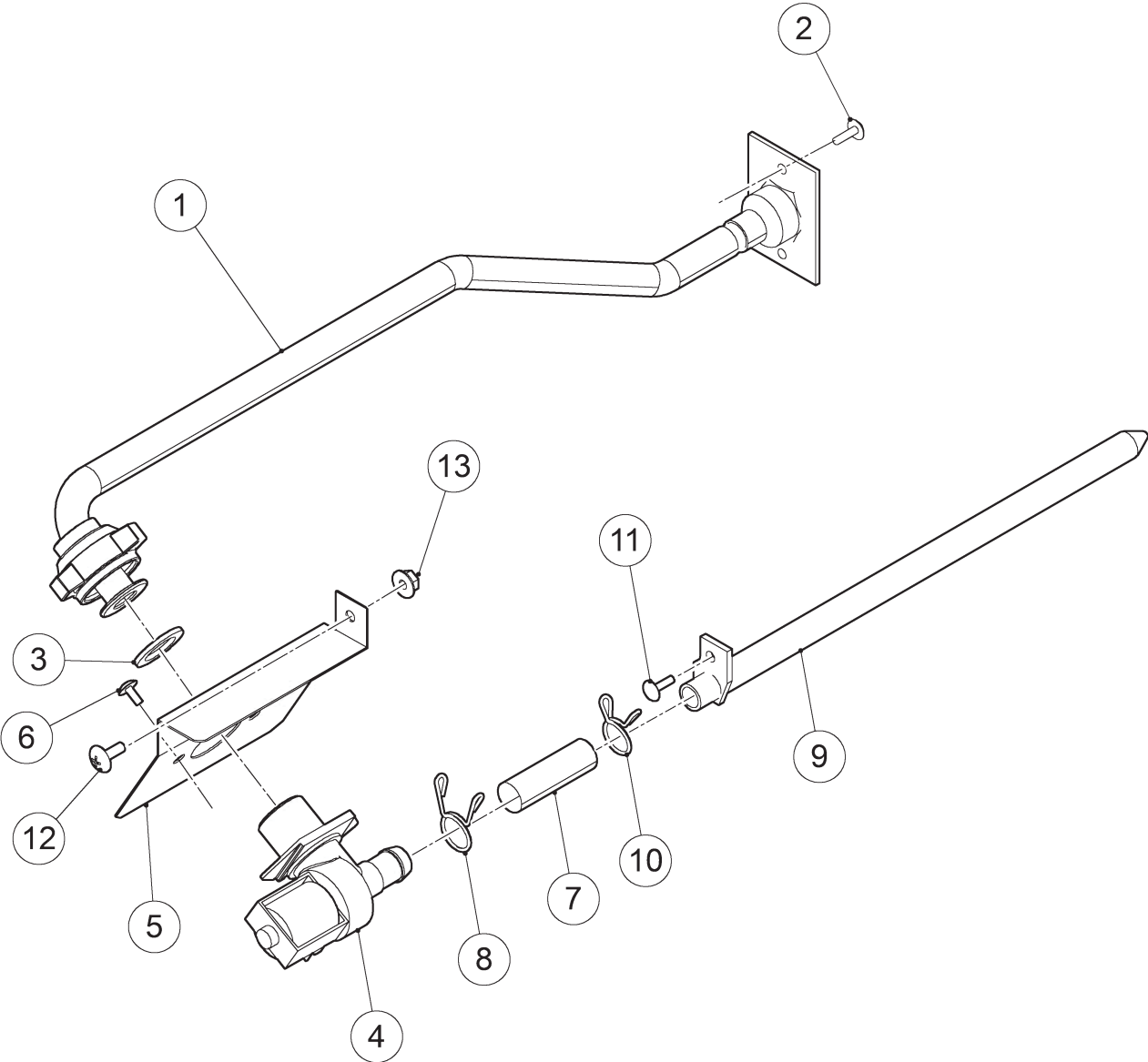

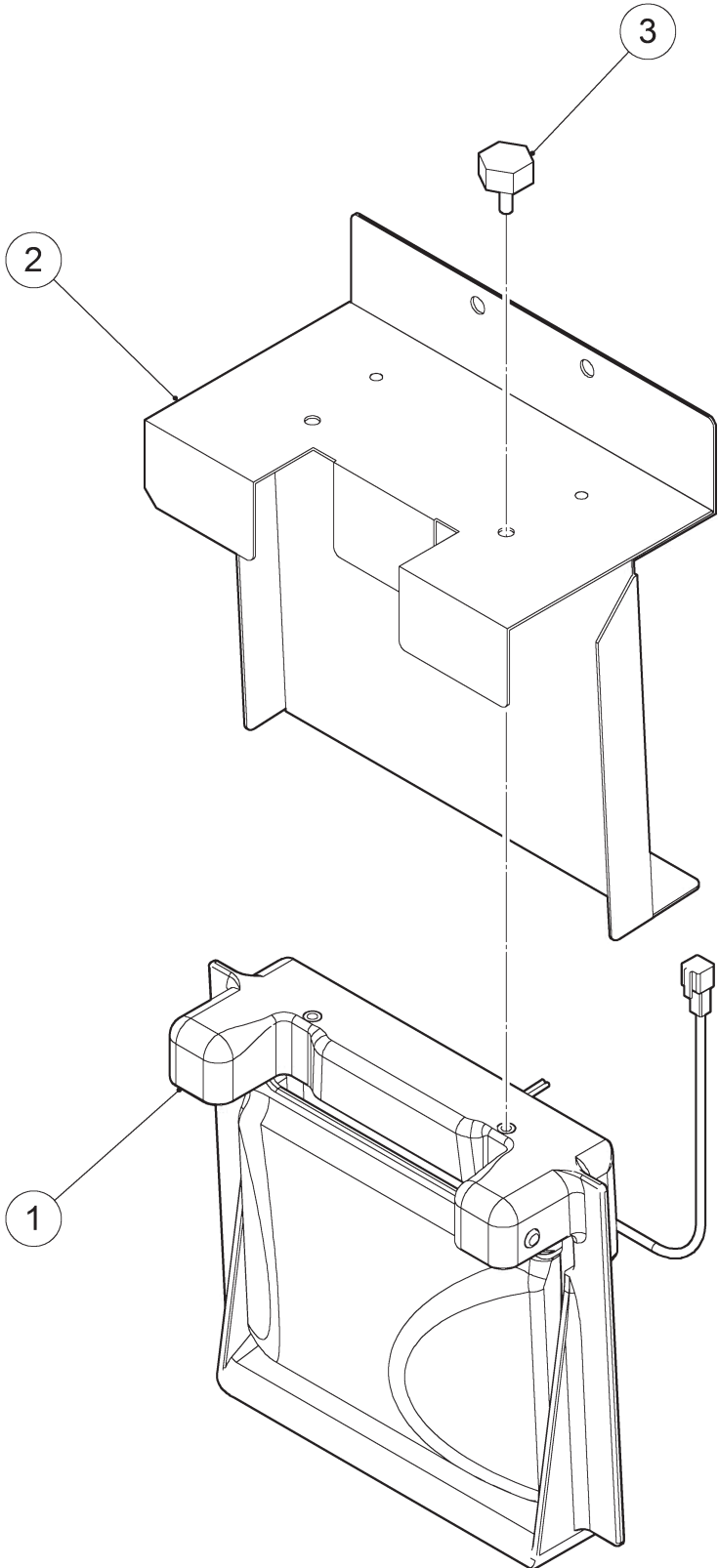

HA

MODEL: IM-200BAA TITLE: E. BIN SW ASSY							
INDEX NO.	DESCRIPTION	MATERIAL OR MODEL NUMBER	PART NUMBER	REQ'D NUMBER			
				E-1 F-0	F-1 G-0	G-1	
1	SWITCH MOUNT		480988G01	1	1	1	
2	BIN CONTROL		2A4393G01	1	1	1	
3	THUMBSCREW		415949G10	2	2	2	

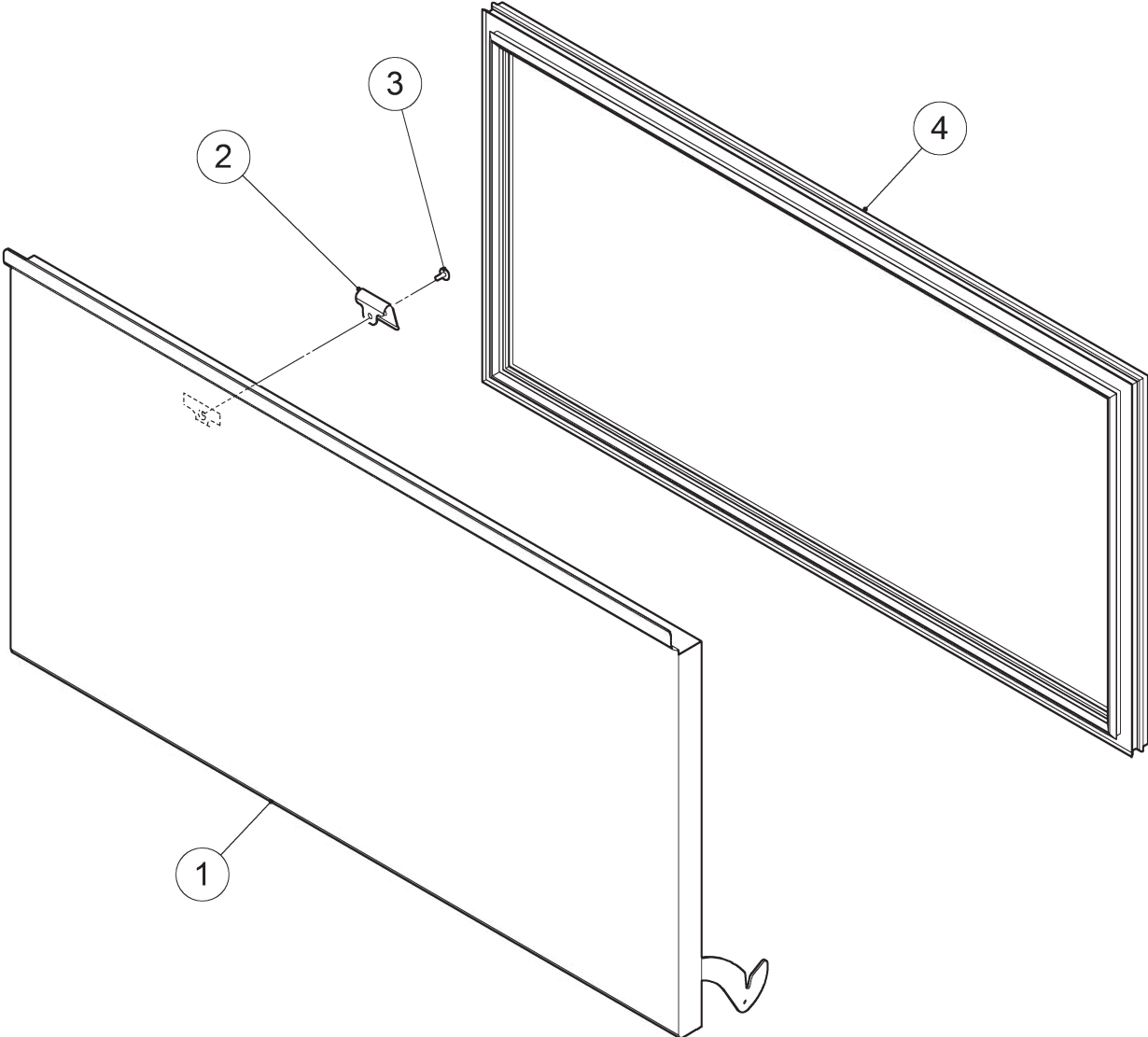

HA

MODEL: IM-200BAA TITLE: F. DOOR ASSY							
INDEX NO.	DESCRIPTION	MATERIAL OR MODEL NUMBER	PART NUMBER	REQ'D NUMBER			
				E-1 F-0	F-1 G-0	G-1	
1	DOOR G		3Y5435G01	1	1	1	
2	CATCH - SLOPE		4X7644-01	1	1	1	
3	T2 TRUSS HEAD SCREW		FT20408M0	1	1	1	
4	DOOR GASKET		3X3545-06	1	1	1	

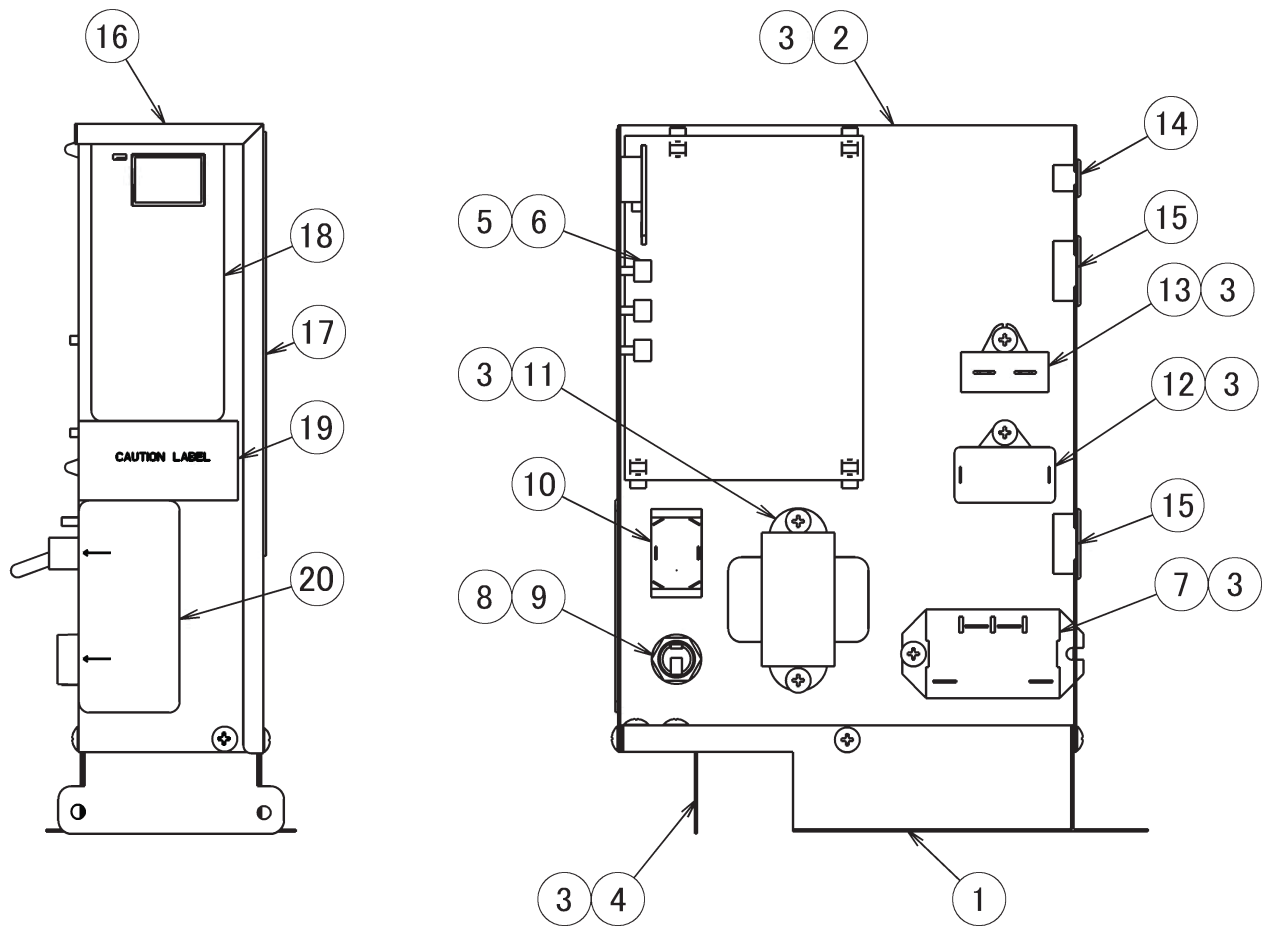

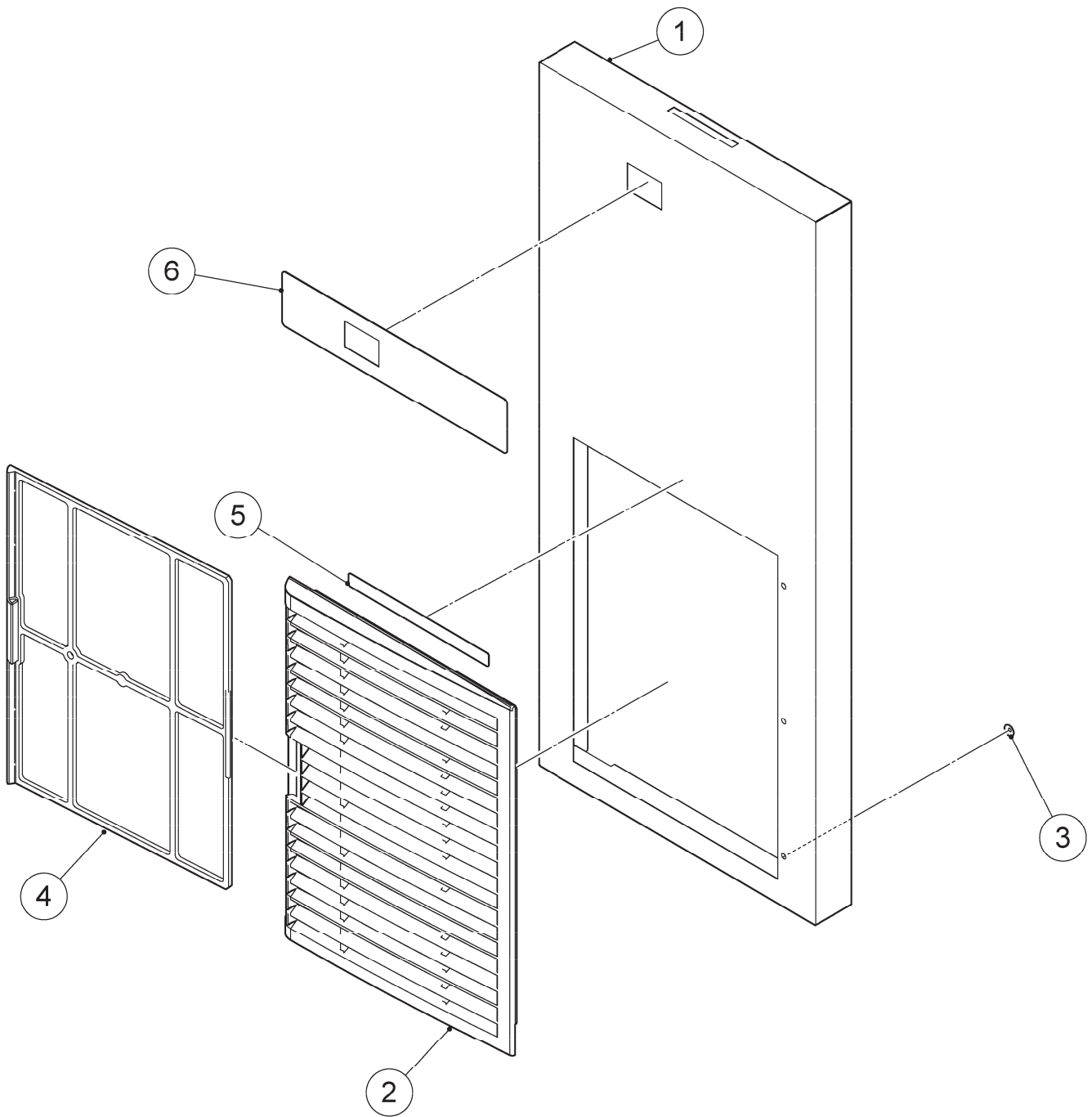

HA

MODEL: IM-200BAA							
TITLE: H. FRONT COVER(R) ASSY							
INDEX NO.	DESCRIPTION	MATERIAL OR MODEL NUMBER	PART NUMBER	REQ'D NUMBER			
				E-1 F-0	F-1 G-0	G-1	
1	FRONT COVER(R)		381970G01	1	1	1	
2	LOUVER (B)		121370P01	1	1	1	
3	PUSH RETAINER		4A2414-01	3	3	3	
4	AIR FILTER (B)		121372G01	1	1	1	
5	LABEL - AIR FILTER		426177-01	1	1	1	
6	OPERATION LABEL		374135L03	1	1	1	

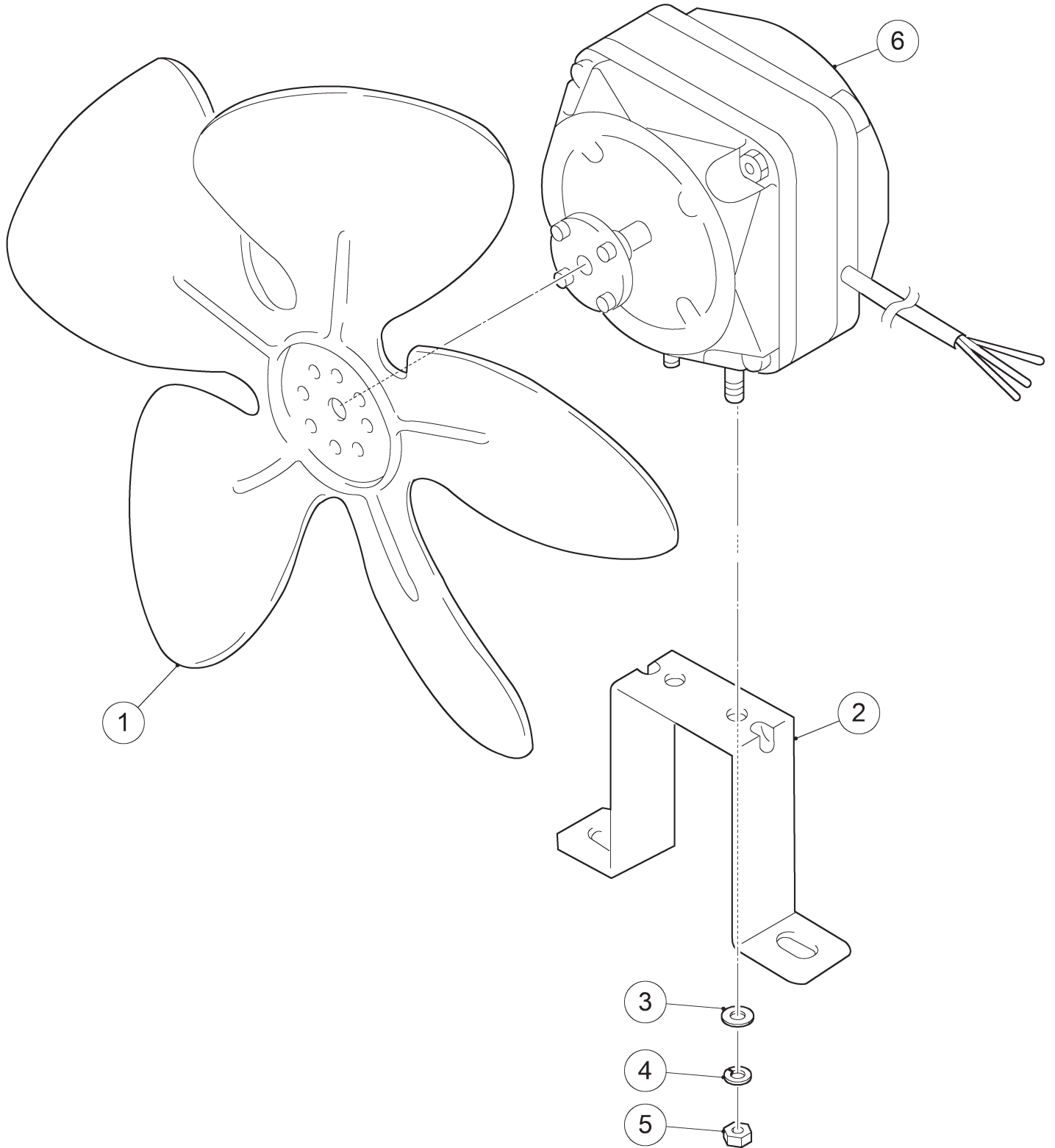

HA

MODEL: IM-200BAA							
TITLE: J. FAN MOTOR ASSY							
INDEX NO.	DESCRIPTION	MATERIAL OR MODEL NUMBER	PART NUMBER	REQ'D NUMBER			
				E-1 F-0	F-1 G-0	G-1	
1	FAN		451771-01	1	1	1	
2	BRACKET - FM		3Y6143M01	1	1	1	
3	FLAT WASHER		FWPL04S0	2	2	2	
4	SPRING WASHER		FWSP04S0	2	2	2	
5	NUT		FNH104S0	2	2	2	
6	FAN MOTOR	M4Q045-CA27-04	P00466-01	1	1	1	

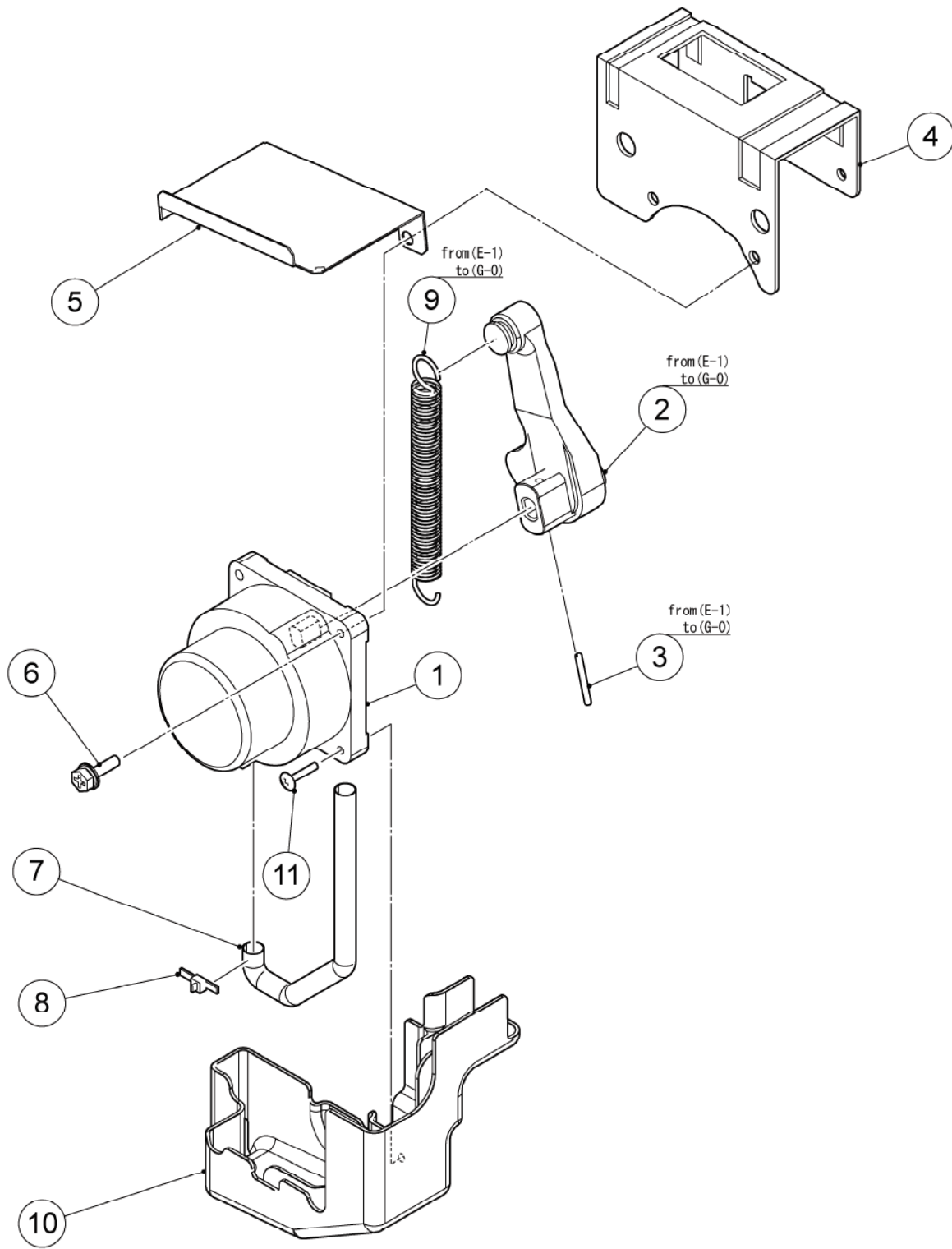

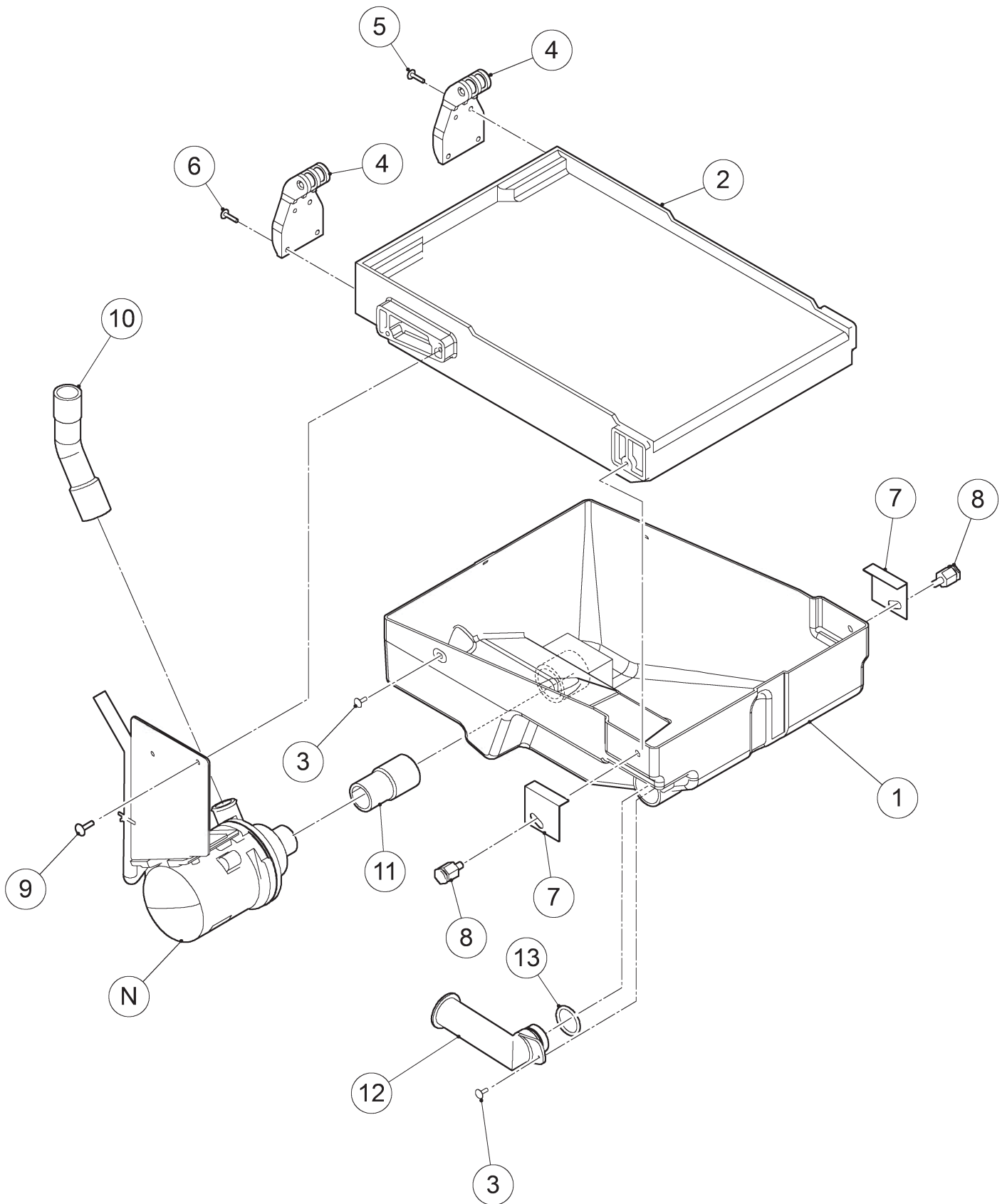

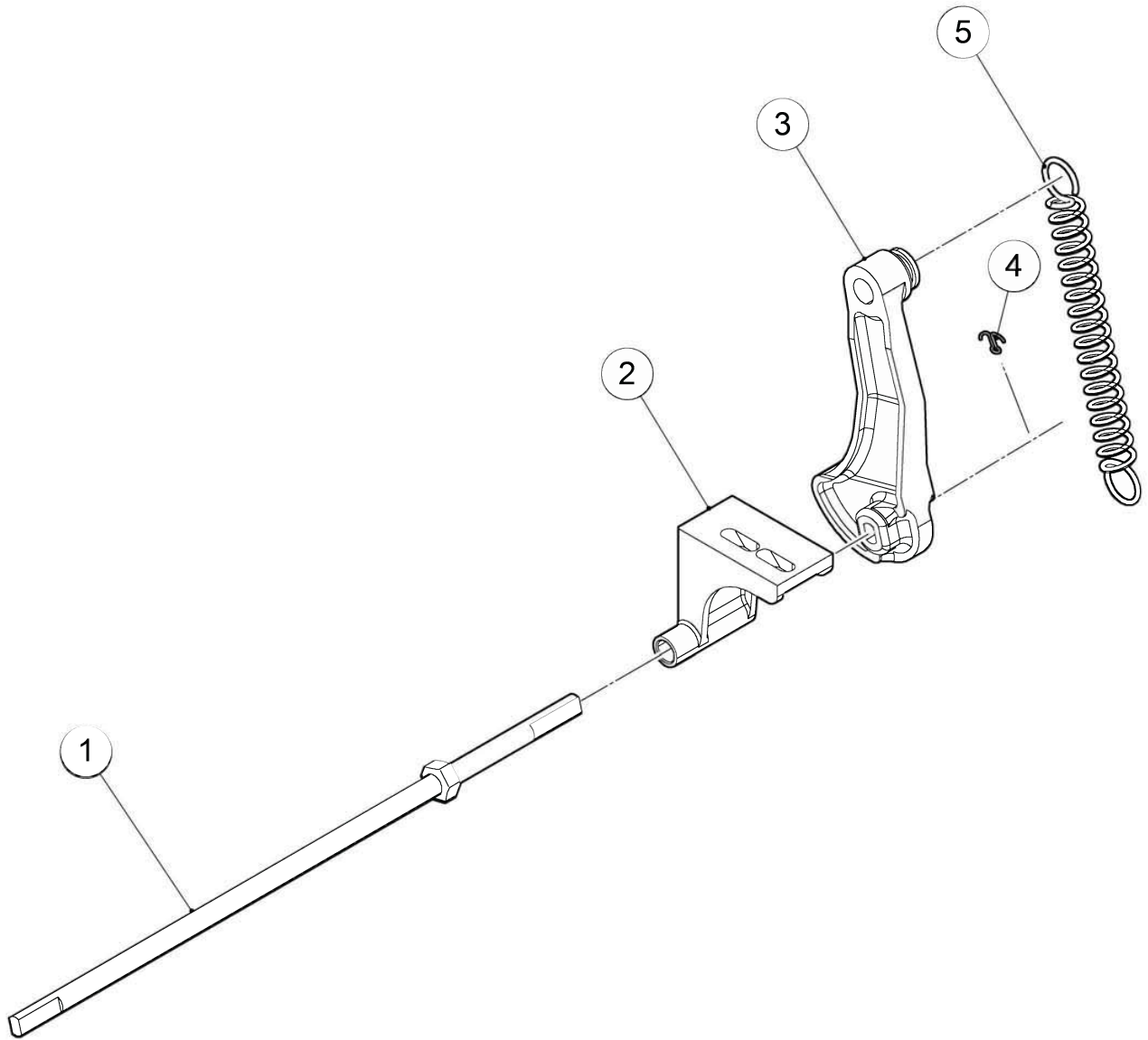

HA

MODEL: IM-200BAA TITLE: M. CAM SHAFT ASSY							
INDEX NO.	DESCRIPTION	MATERIAL OR MODEL NUMBER	PART NUMBER	REQ'D NUMBER			
				E-1 F-0	F-1 G-0	G-1	
1	CAM SHAFT		4H2702G02	1	1	1	
2	BEARING-CAM SHAFT		3X8307-02	1	1	1	
3	CAM(B)		376546P01	1	1	1	
4	CUTTER PIN		711S-0212	1	1	1	
5	SPRING		481332M01	1	1	1	

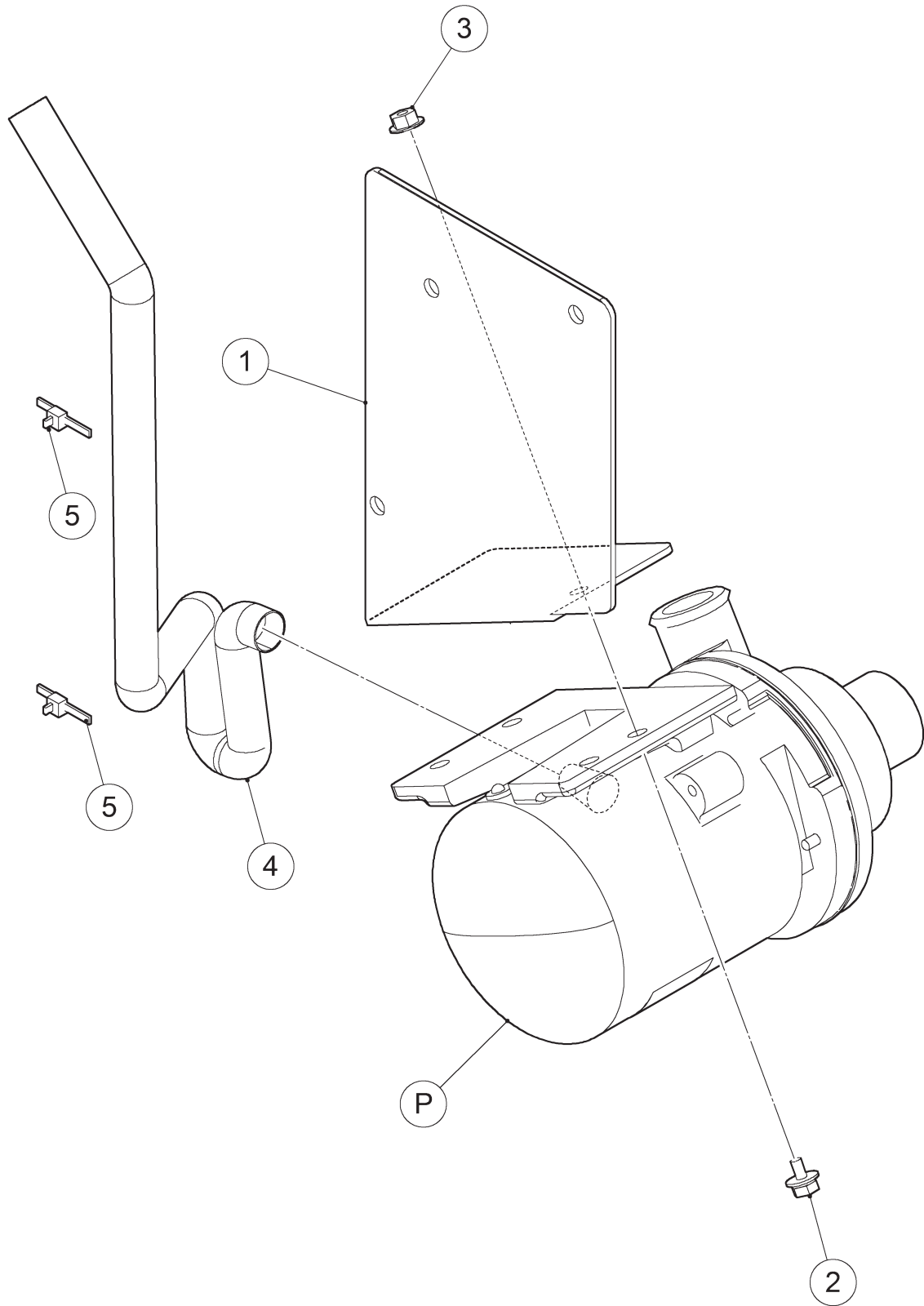

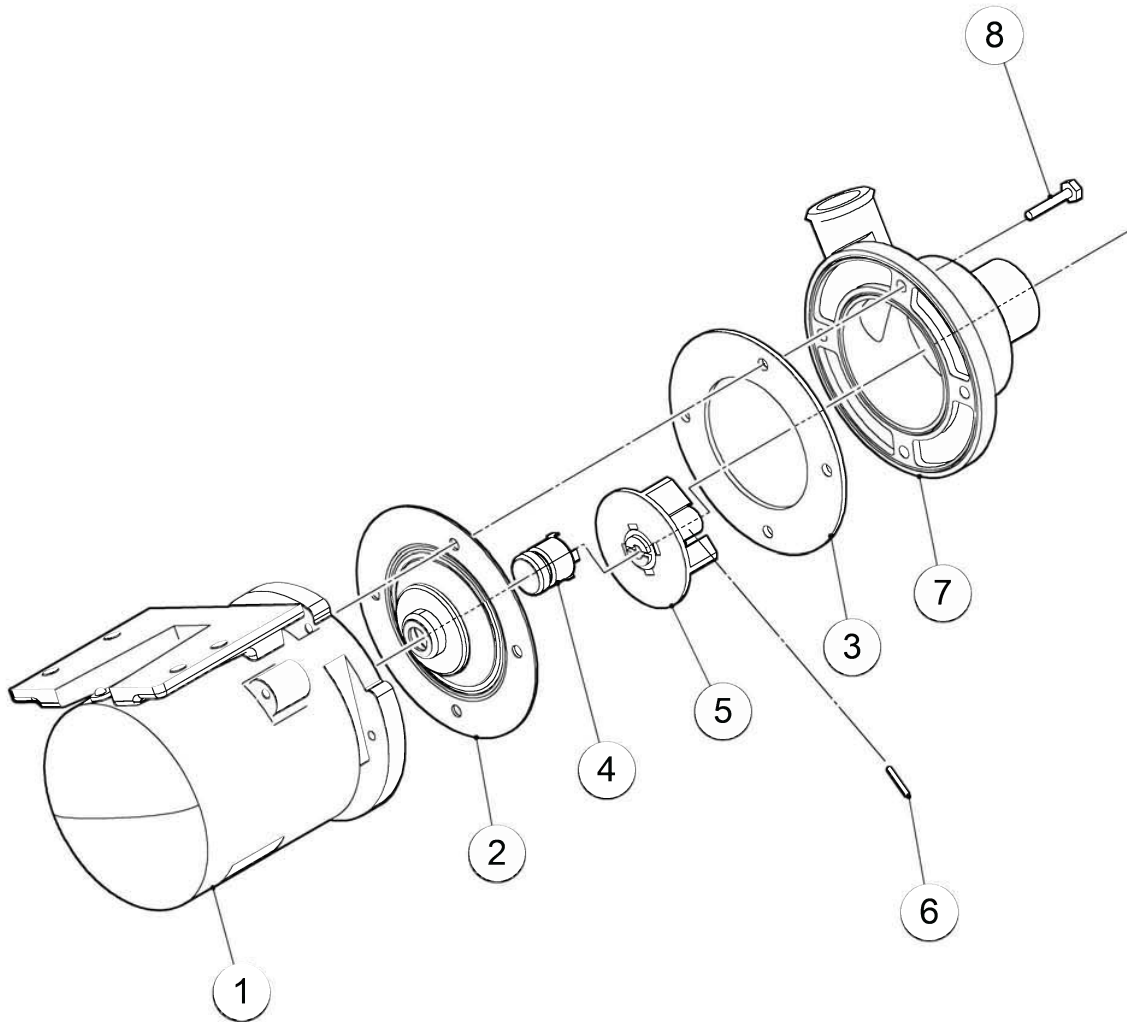

HA

MODEL: IM-200BAA							
TITLE: P. PUMP MOTOR							
INDEX NO.	DESCRIPTION	MATERIAL OR MODEL NUMBER	PART NUMBER	REQ'D NUMBER			
				E-1 F-0	F-1 G-0	G-1	
1	PUMP MOTOR		2A2758-01	1	1	1	
2	PUMP FLANGE		3A2988-01	1	1	1	
3	PUMP GASKET		4A2974-01	1	1	1	
4	MECHANICAL SEAL		465627-01	1	1	1	
5	IMPELLER		433522-01	1	1	1	
6	PIN		4A0648-01	1	1	1	
7	PUMP HOUSING		261284P01	1	1	1	
8	SCREW		4A3871-01	4	4	4	

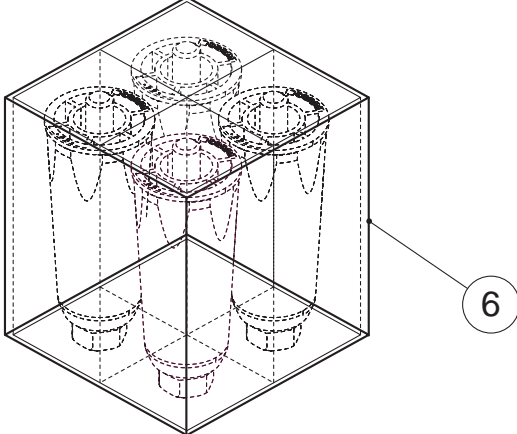
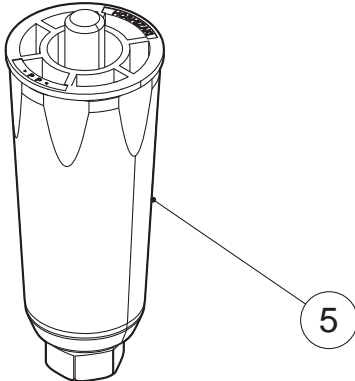
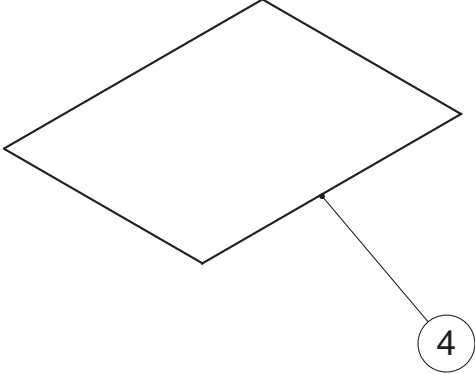
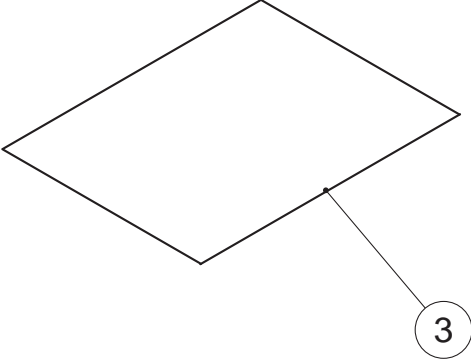
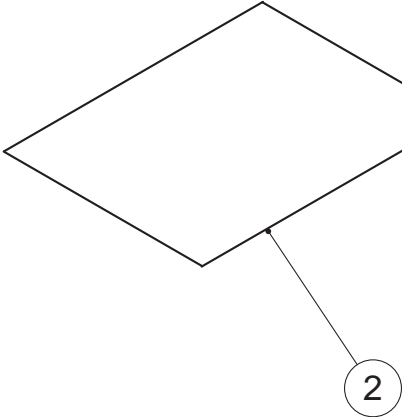
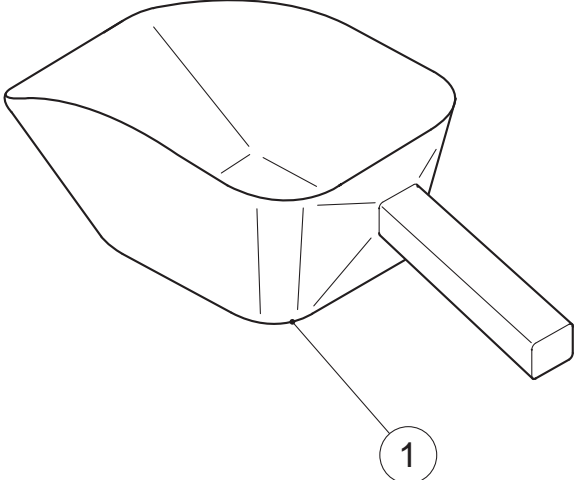

HA

MODEL: IM-200BAA							
TITLE: Q. ACCESSORIES							
INDEX NO.	DESCRIPTION	MATERIAL OR MODEL NUMBER	PART NUMBER	REQ'D NUMBER			
				E-1 F-0	F-1 G-0	G-1	
1	SCOOP		1H4123P02	1	1	1	
2	CERTIFICATE-WARRANTY		263553L01	1	1	1	
3	REGISTRATION CARD		2A2894-01	1	1	1	
4	INSTRUCTION MANUAL		L1M063101	1	1	1	
5	LEG-UNC		371053G01	1	1	1	
6	LEG SET-UNC		472736A01	1	1	1	