



# HOSHIZAKI

## Parts List

Modular Crescent Cuber

Models

KM-1100MAJ, MWJ, MRJ, MRJZ



[hoshizakiamerica.com](http://hoshizakiamerica.com)

Number: 71392  
Issued: 12-12-2017  
Revised: 5-3-2023

## CONTENTS

Auxiliary Codes.....	3
Note About Ordering Parts .....	3
KM-1100MAJ .....	4
KM-1100MWJ .....	7
KM-1100MRJ(Z) .....	9
B. Water Circuit .....	12
C. Control Box Assembly .....	15
D. Accessories & Labels .....	16

## Auxiliary Codes

### KM-1100MAJ

G-0 August 2017  
H-0 January 2018  
J-0 January 2019  
K-0 January 2020  
L-0 January 2021  
L-1 April 2021  
L-2 June 2021  
L-3 August 2021  
L-1(M) December 2021  
M-0 January 2022  
N-0 January 2023

### KM-1100MWJ

G-0 August 2017  
H-0 May 2018  
K-0 February 2020  
L-0 March 2021  
L-1 May 2021  
L-2 June 2021  
L-3 August 2021  
L-4 September 2021  
L-0(K) October 2021  
M-0 January 2022  
N-0 April 2023

### KM-1100MRJ

G-0 August 2017  
G-1 December 2017  
H-0 January 2018  
J-0 February 2019  
K-0 February 2020  
L-0 March 2021  
L-1 April 2021  
L-2 June 2021  
L-3 August 2021  
L-4 September 2021  
L-0(K) October 2021

### KM-1100MRJZ

M-0 January 2022  
N-0 January 2023

## Auxiliary Code Breakdown

The auxiliary code is the first two characters in the serial number. The first character indicates the year. Years progress or regress in alphabetical order. The series runs from "A" through "V" and the letters "I" and "O" are skipped. The second character indicates significant part changes within a year. Base is "0" and this number advances for each change. In cases where there is a letter in parentheses, this designates the month. This is the last character in the serial number. The series runs from "(A)" through "(M)" and the letter "(I)" is skipped. This designation is only included when identifying a parts change within an auxiliary code.

## Note About Ordering Parts

Most assemblies cannot be ordered as complete units; parts in the assemblies generally must be ordered separately.

**A. Main Assembly & Refrigeration Circuit**  
**KM-1100MAJ**  
 G-0 to N-0

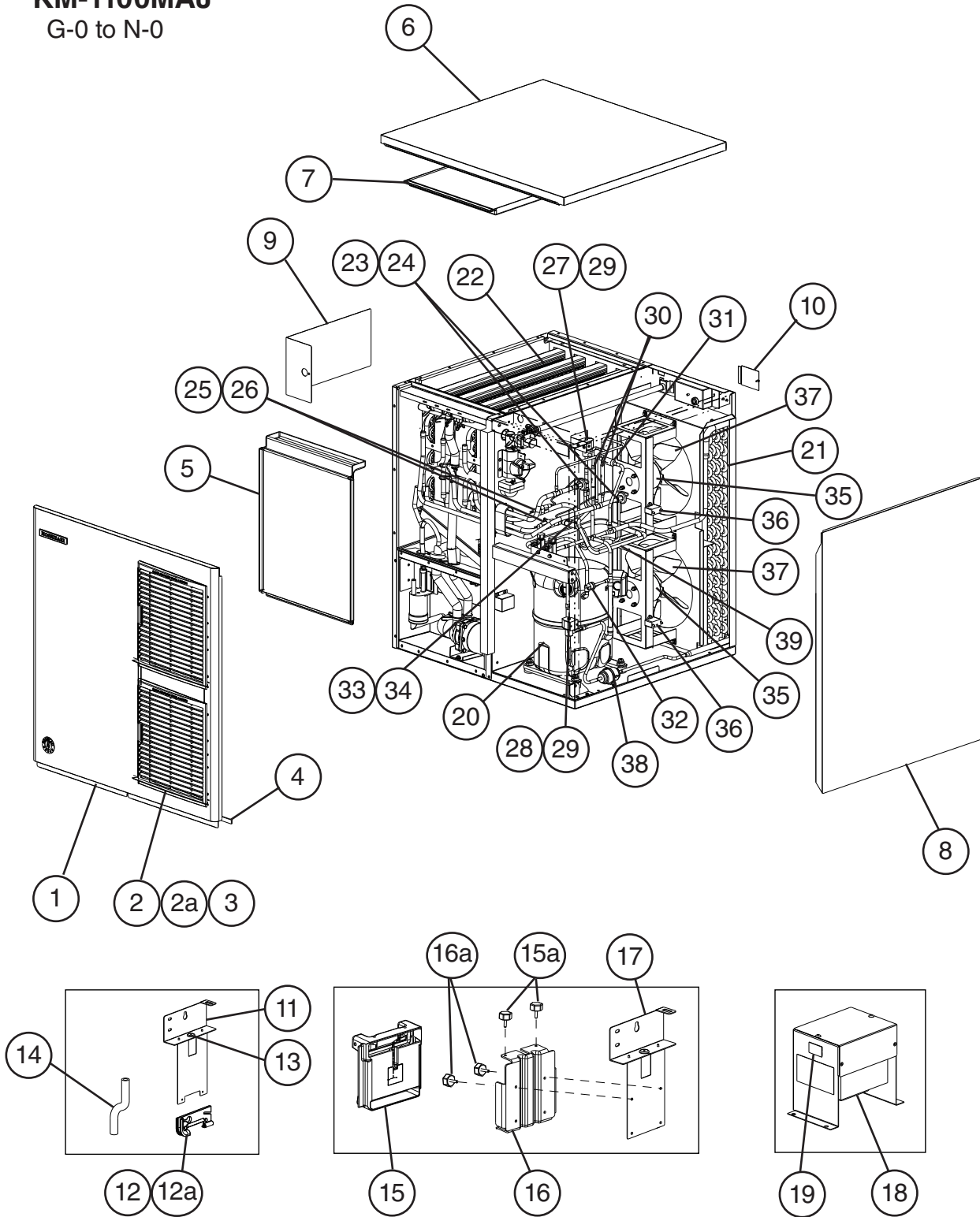

For Bin Control Thermostat,  
 see "C. Control Box Assembly"

Title: A. Main Assembly & Refrigeration Circuit Model: KM-1100MAJ												
Index No.	Description	Material or Model Number	Part Number	Required Number								
				G-0 to L-0	L-1 L-2	L-3	M-0 N-0					
<b>Main Assembly</b>												
1	Front Panel		1A6367A01	1	1	1	1					
2	Louver		1A0547-01	2	2	2	2					
2a	Push Retainer		4A2414-01	6	6	-						
3	Air Filter		2A2062G01	2	2	2	2					
4	Gasket	L=762 mm	4A0808L02	1	1	1	1					
5	Front Insulation		3A8392G01	1	1	1	1					
6	Top Panel		3A1941A01	1	1	1	1					
7	Top Insulation		322714G01	1	1	1	1					
8	Right Side Panel		1A3617G01	1	1	1	1					
9	Control Box Cover		3A9007-01	1	1	-	-					
			3B1113-01			1	1					
10	Junction Box Cover		433410-01	1	1	1	1					
11	Thermostatic Bulb Holder Bracket		322815G02	1	1	-	-					
12	Thermostatic Bulb Holder		3A3903-01	1	1	-	-					
12a	Thumbscrews		415949G10	2	2	-	-					
13	Thermostatic Capillary Tube Bushing		425307-02	1	1	-	-					
14	Silicone Hose	L=285 mm	7730I3812	1	1	-	-					
15	Mechanical Bin Control		2A8598G01			1	1					
15a	Thumbscrews		415949G10			2	2					
16	Mechanical Bin Control Bracket		3A6040-01			1	1					
16a	Thumbscrews		415949G10			2	2					
17	Mechanical Bin Control Extension Bracket		4A7068G01			1	1					
18	Main Transformer		4A5695-01	1	1	1	1					
19	Voltage Tap Switch		4A1477-01	1	1	1	1					
<b>Refrigeration Circuit</b>												
20	Compressor		4A1539-03	1	1	1	1					
21	Condenser		1A4459-01	1	1	1	1					
22	Evaporator		1A3820G01	1	1	1	1					
23	Thermostatic Expansion Valve		4A4008-02	2	2	2	2					
24	Thermostatic Expansion Valve Cover		3A0944-01	2	2	2	2					
25	Thermostatic Expansion Valve Bulb Holder		3A0107-01	2	2	2	2					
26	Clamp		443461-02	2	2	2	2					
27	Hot Gas Valve Body		4A3978-01	1	1	1	1					
28	Liquid Line Valve Body		4A3276-01	1	1	1	1					
29	Valve Coil		4A3277-01	2	2	2	2					
30	Check Valve		4A1373-01	2	2	2	2					
31	Strainer		441569-02	1	1	1	1					
32	High-Pressure Switch		463180-04	1	1	1	1					
33	Thermistor		429006-03	1	1	1	1					
34	Thermistor Holder		427430-01	1	1	1	1					

**Title: A. Main Assembly & Refrigeration Circuit    Model: KM-1100MAJ**

Index No.	Description	Material or Model Number	Part Number	Required Number								
				G-0 to L-0	L-1 L-2	L-3	M-0 N-0					
35	Fan Motor		4A3158-01	2	-							
			4A6115-01		2	2	2					
36	Fan Motor Capacitor	5 MFD, 250VAC	4A6435-02	2	2	2	2					
37	Fan Blade		4A3959-01	2	2	2	2					
38	Drier		4A1113-01	1	1	1	1					
39	Heat Exchanger		1A3601G01	1	1	1	1					

**A. Main Assembly & Refrigeration Circuit**  
**KM-1100MWJ**  
 G-0 to N-0

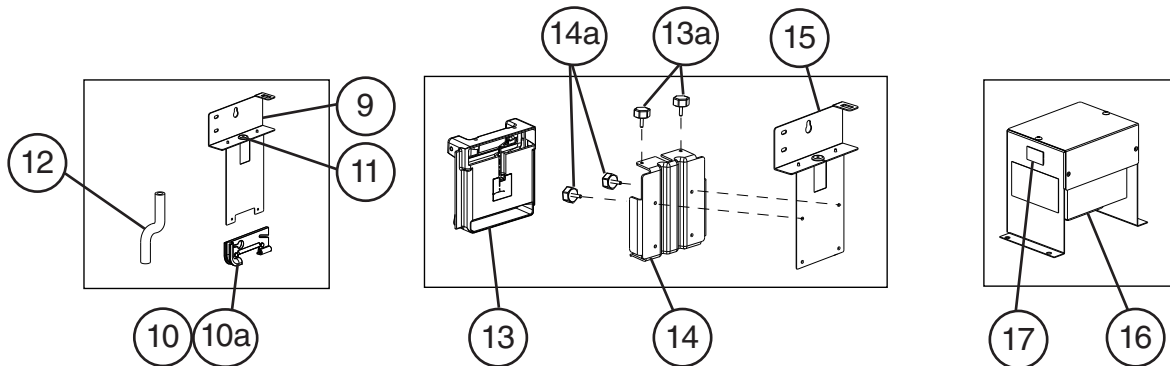
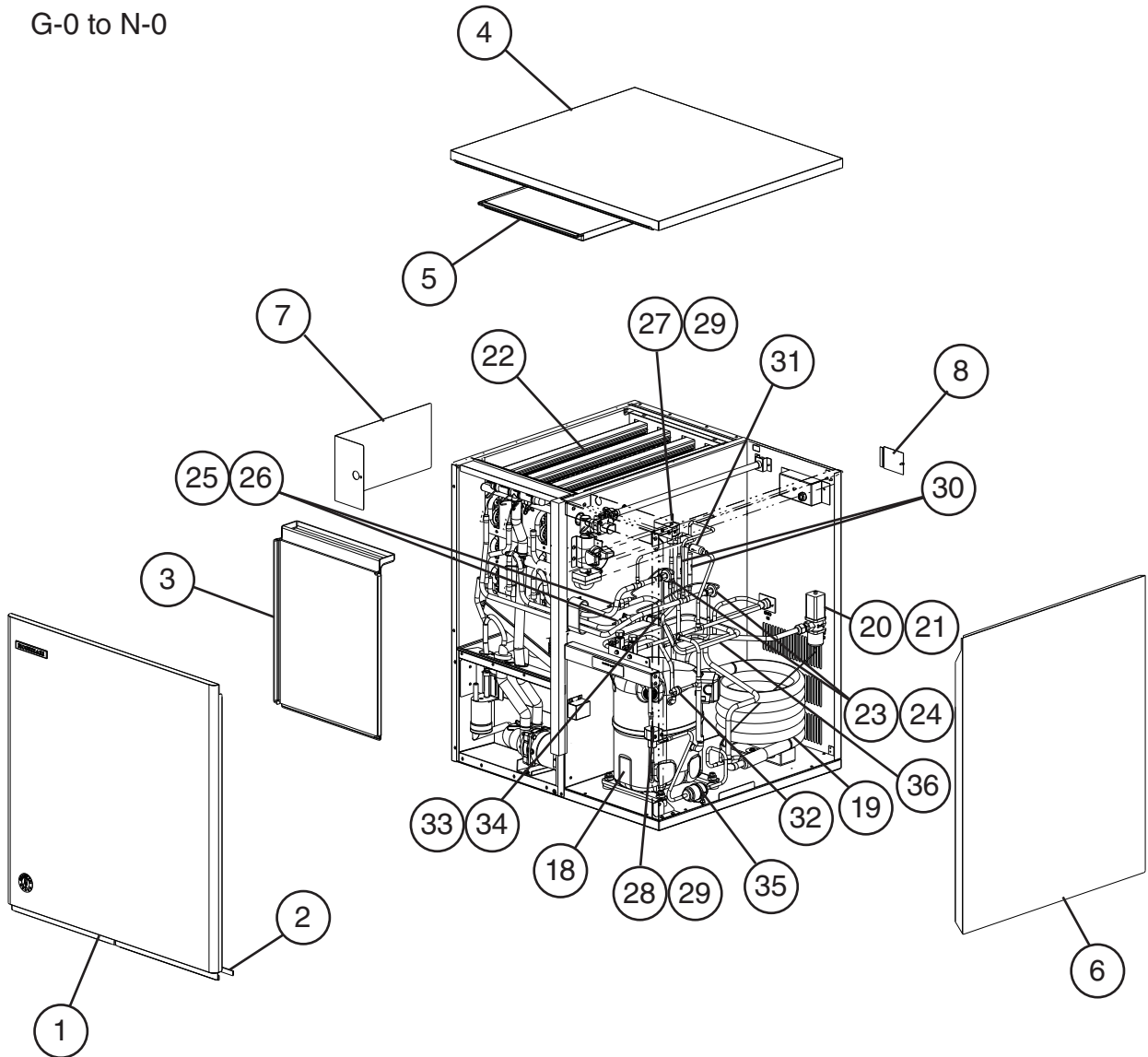

For Bin Control Thermostat,  
 see "C. Control Box Assembly"

Title: A. Main Assembly & Refrigeration Circuit Model: KM-1100MWJ												
Index No.	Description	Material or Model Number	Part Number	Required Number								
				G-0 to L-4	M-0 N-0							
<b>Main Assembly</b>												
1	Front Panel		1A6376A01	1	1							
2	Gasket	L=762 mm	4A0808L02	1	1							
3	Front Insulation		3A8392G01	1	1							
4	Top Panel		3A1941A01	1	1							
5	Top Insulation		322714G01	1	1							
6	Right Side Panel		1A3617G01	1	1							
7	Control Box Cover		3A9007-01	1	-							
			3B1113-01		1							
8	Junction Box Cover		433410-01	1	1							
9	Thermostatic Bulb Holder Bracket		322815G02	1	-							
10	Thermostatic Bulb Holder		3A3903-01	1	-							
10a	Thumbscrews		415949G10	2	-							
11	Thermostatic Capillary Tube Bushing		425307-02	1	-							
12	Silicone Hose	L=285 mm	773013812	1	-							
13	Mechanical Bin Control		2A8598G01		1							
13a	Thumbscrews		415949G10		2							
14	Mechanical Bin Control Bracket		3A6040-01		1							
14a	Thumbscrews		415949G10		2							
15	Mechanical Bin Control Extension Bracket		4A7068G01		1							
16	Main Transformer		4A5695-01	1	1							
17	Voltage Tap Switch		4A1477-01	1	1							
<b>Refrigeration Circuit</b>												
18	Compressor		4A1539-03	1	1							
19	Condenser		3A7323-01	1	1							
20	Water Regulating Valve		4A0911-07	1	1							
21	Male Connector		4A1087-01	1	1							
22	Evaporator		1A3820G01	1	1							
23	Thermostatic Expansion Valve		4A4008-02	2	2							
24	Thermostatic Expansion Valve Cover		3A0944-01	2	2							
25	Thermostatic Expansion Valve Bulb Holder		3A0107-01	2	2							
26	Clamp		443461-02	2	2							
27	Hot Gas Valve Body		4A3978-01	1	1							
28	Liquid Line Valve Body		4A3276-01	1	1							
29	Valve Coil		4A3277-01	2	2							
30	Check Valve		4A1373-01	2	2							
31	Strainer		441569-02	1	1							
32	High-Pressure Switch		463180-05	1	1							
33	Thermistor		429006-03	1	1							
34	Thermistor Holder		427430-01	1	1							
35	Drier		4A1113-01	1	1							
36	Heat Exchanger		1A3601G01	1	1							



**A. Main Assembly & Refrigeration Circuit**  
**KM-1100MRJ(Z)**  
 G-0 to N-0

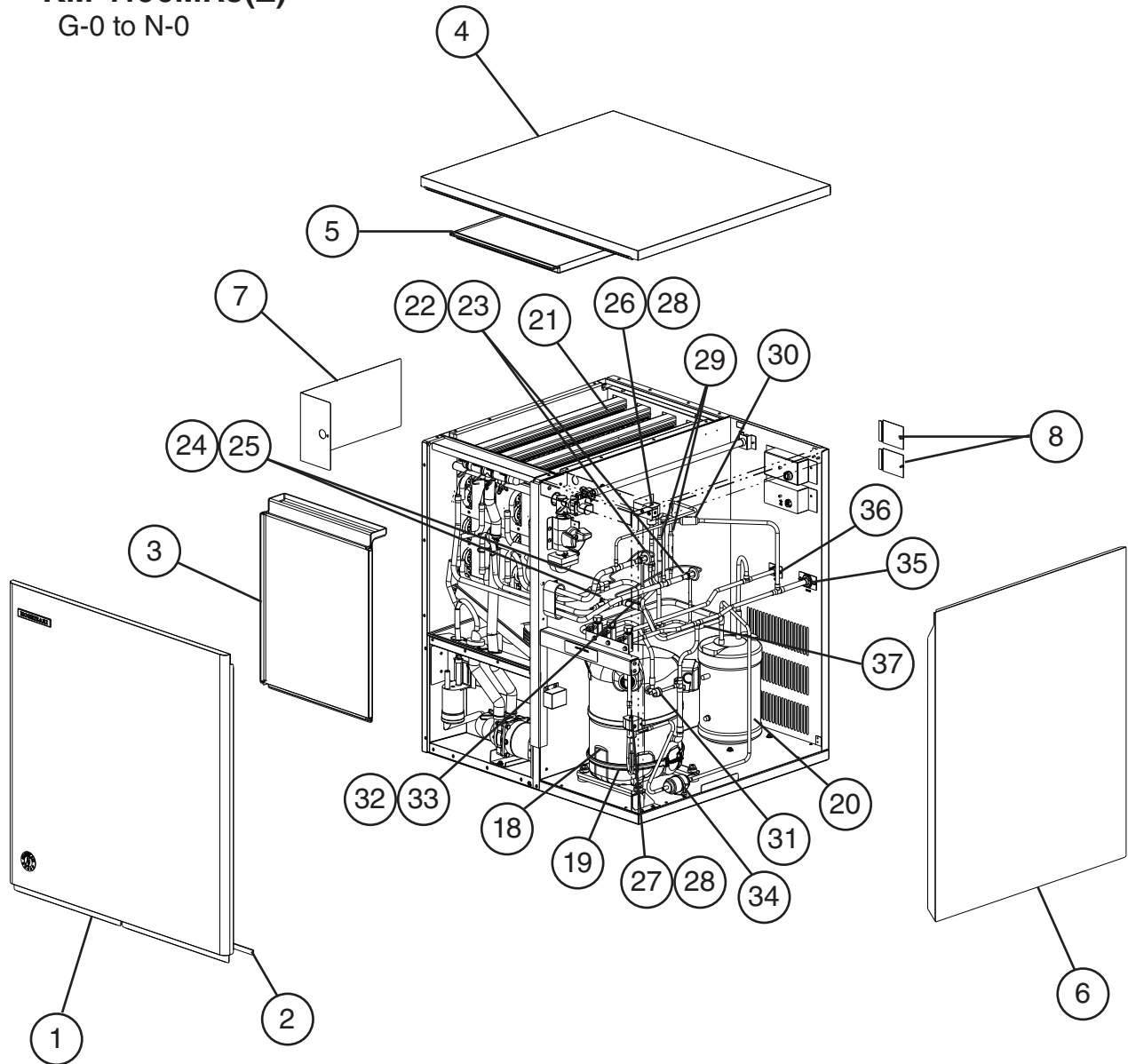

For Bin Control Thermostat,  
 see "C. Control Box Assembly"

Title: A. Main Assembly & Refrigeration Circuit Model: KM-1100MRJ(Z)												
Index No.	Description	Material or Model Number	Part Number	Required Number								
				G-0 to L-4	M-0 N-0							
<b>Main Assembly</b>												
1	Front Panel		1A6376A01	1	1							
2	Gasket	L=762 mm	4A0808L02	1	1							
3	Front Insulation		3A8392G01	1	1							
4	Top Panel		3A1941A01	1	1							
5	Top Insulation		322714G01	1	1							
6	Right Side Panel		1A3617G01	1	1							
7	Control Box Cover		3A9007-01	1	-							
			3B1113-01		1							
8	Junction Box Cover		433410-01	2	2							
9	Thermostatic Bulb Holder Bracket		322815G02	1	-							
10	Thermostatic Bulb Holder		3A3903-01	1	-							
10a	Thumbscrews		415949G10	2	-							
11	Thermostatic Capillary Tube Bushing		425307-02	1	-							
12	Silicone Hose	L=285 mm	7730I3812	1	-							
13	Mechanical Bin Control		2A8598G01		1							
13a	Thumbscrews		415949G10		2							
14	Mechanical Bin Control Bracket		3A6040-01		1							
14a	Thumbscrews		415949G10		2							
15	Mechanical Bin Control Extension Bracket		4A7068G01		1							
16	Main Transformer		4A5695-01	1	1							
17	Voltage Tap Switch		4A1477-01	1	1							
<b>Refrigeration Circuit</b>												
18	Compressor		4A1539-03	1	1							
19	Crankcase Heater		4A5397-02	1	1							
20	Receiver		4A6213-01	1	1							
21	Evaporator		1A3820G01	1	1							
22	Thermostatic Expansion Valve		4A4008-02	2	2							
23	Thermostatic Expansion Valve Cover		3A0944-01	2	2							
24	Thermostatic Expansion Valve Bulb Holder		3A0107-01	2	2							
25	Clamp		443461-02	2	2							
26	Hot Gas Valve Body		4A3978-01	1	1							
27	Liquid Line Valve Body		4A3276-01	1	1							
28	Valve Coil		4A3277-01	2	2							
29	Check Valve		4A1373-01	2	2							
30	Strainer		441569-02	1	1							
31	High-Pressure Switch		463180-04	1	1							
32	Thermistor		429006-03	1	1							
33	Thermistor Holder		427430-01	1	1							
34	Drier		4A1113-01	1	1							

Title: A. Main Assembly & Refrigeration Circuit Model: KM-1100MRJ(Z)												
Index No.	Description	Material or Model Number	Part Number	Required Number								
				G-0 to L-4	M-0 N-0							
35	Discharge Line Coupling	<b>KM-1100MRJ/3</b>	434136G01	1	-							
	Discharge Line Service Valve	<b>KM-1100MRJZ/3</b>	4A4822-01		1							
36	Liquid Line Coupling	<b>KM-1100MRJ/3</b>	4A3887G01	1	-							
	Liquid Line Service Valve	<b>KM-1100MRJZ/3</b>	4A3491-01		1							
37	Heat Exchanger		1A3601G01	1	1							

**B. Water Circuit**  
**KM-1100M\_J(Z)**  
 G-0 to N-0

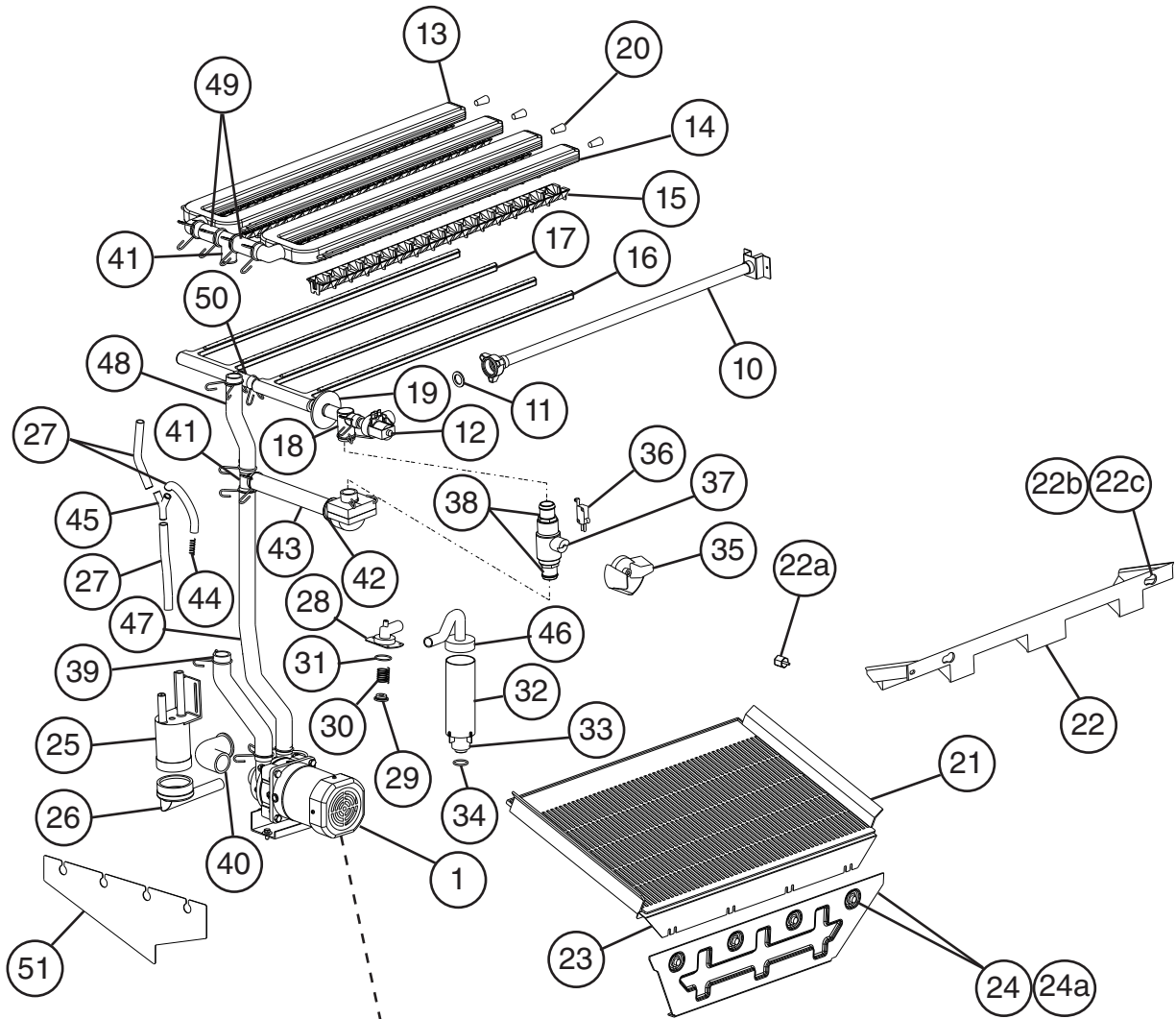

**Pump Motor Assembly**

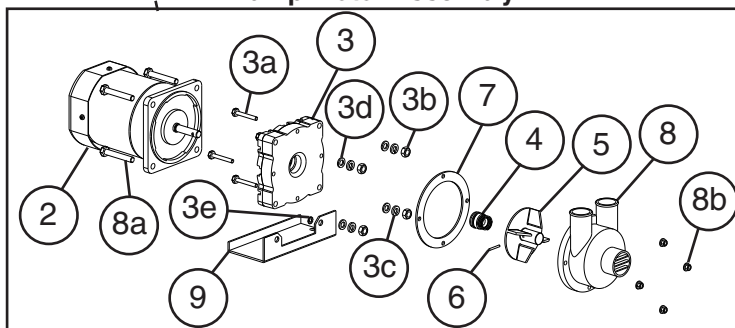

**Title: B. Water Circuit Model: KM-1100M\_J(Z)**

Index No.	Description	Material or Model Number	Part Number	Required Number																
				G-0 to L-1	L-2 to N-0															
1	Pump Motor Assembly (includes items 2 through 9)	S-0731	215693A01	1	1															
2	Pump Motor		3A7682-01	1	-															
			2U0106-01		1															
3	Pump Flange		215662-01	1	1															
3a	Hex Bolt	4x30	7B02-0430	4	4															
3b	Hex Nut		7N12-0600	4	4															
3c	Split Lock Washer		7L22-0600	4	4															
3d	Flat Washer		7W22-0600	4	4															
3e	Tooth Washer		7R22-0600	1	1															
4	Mechanical Seal		4A3820-01	1	1															
5	Impeller		428548-01	1	1															
6	Pin		4A0648-01	1	1															
7	Packing		428547-01	1	1															
8	Pump Housing		212636-01	1	1															
8a	Hex Bolt	6x40	7B02-0640	4	4															
8b	Hex Flange Nut		7J02-0400	4	4															
9	Pump Motor Bracket		435057-01	1	1															
10	Water Supply Pipe		4A5216G04	1	1															
11	Rubber Gasket		413854-03	1	1															
12	Inlet Water Valve		3U0111-01	1	1															
13	Left Spray Tube		1A0260-02	1	1															
14	Right Spray Tube		1A0260-01	1	1															
15	Spray Guide		2A4282-02	4	4															
16	Right Water Supply Tube		2A0079-02	1	1															
17	Left Water Supply Tube		2A0079-01	1	1															
18	Distributor A (Tee)		4A0177-01	1	1															
19	Flange		439267-01	1	1															
20	Plug		4A0176-01	4	4															
21	Cube Guide A		214905-01	1	1															
22	Cube Guide B		322644-02	1	1															
22a	Thumbscrew		415949G10	1	1															
22b	Collar		435269-01	1	1															
22c	Screw	4x6	7C22-0412	2	2															
23	Plate		3A0133-01	1	1															
24	Separator		322688-01	1	1															
24a	T2 Screw	4x10	7P32-0410	4	4															
25	Float Switch		4A3624-02	1	1															
26	Float Switch Connector		426799-01	1	1															
27	Silicone Hose	L=135 mm (each)	773013812	3	3															
28	Drain Valve Housing		3A1170-01	1	1															
29	Valve Seat		433705-01	1	1															
30	Spring		322685-01	1	1															
31	O-Ring		7611-G035	1	1															
32	Overflow Cap		322816-01	1	1															
33	Overflow Pipe		322691-02	1	1															
34	O-Ring		4A1234-01	1	1															

**Title: B. Water Circuit Model: KM-1100M\_J(Z)**

Index No.	Description	Material or Model Number	Part Number	Required Number										
				G-0 to L-1	L-2 to N-0									
35	Cleaning Valve Handle		215383-01	1	1									
36	Cleaning Valve Microswitch		4A2546-01	1	1									
37	Cleaning Valve Ball Valve		439293-01	1	1									
38	Cleaning Valve Male Adaptor		325826-01	2	2									
39	Drain Hose		435092-01	1	1									
40	Inlet Hose A		435091-01	1	1									
41	Distributor B (Tee)		432426-01	2	2									
42	Rubber Ring		439236-01	1	1									
43	Bypass Hose		439265-01	1	1									
44	Spring		435825-01	1	1									
45	Connector		432763-01	1	1									
46	Hose (C)		326655-01	1	1									
47	Vinyl Hose	L=470 mm	7716-2025	1	1									
48	Vinyl Hose	L=170 mm	7716-2025	1	1									
49	Vinyl Hose	L=63 mm	7716-2025	2	2									
50	Vinyl Hose	L=47 mm	7716-1519	1	1									
51	Splash Guard		4A6118-01	1	1									
<b>Hose Clamps</b>														
	Hose Clamp	25 mm	427443-03	11	11									
		18 mm	427443-05	3	3									
		27 mm	427443-08	2	2									

**C. Control Box Assembly**  
**KM-1100M\_J(Z)**  
 G-0 to N-0

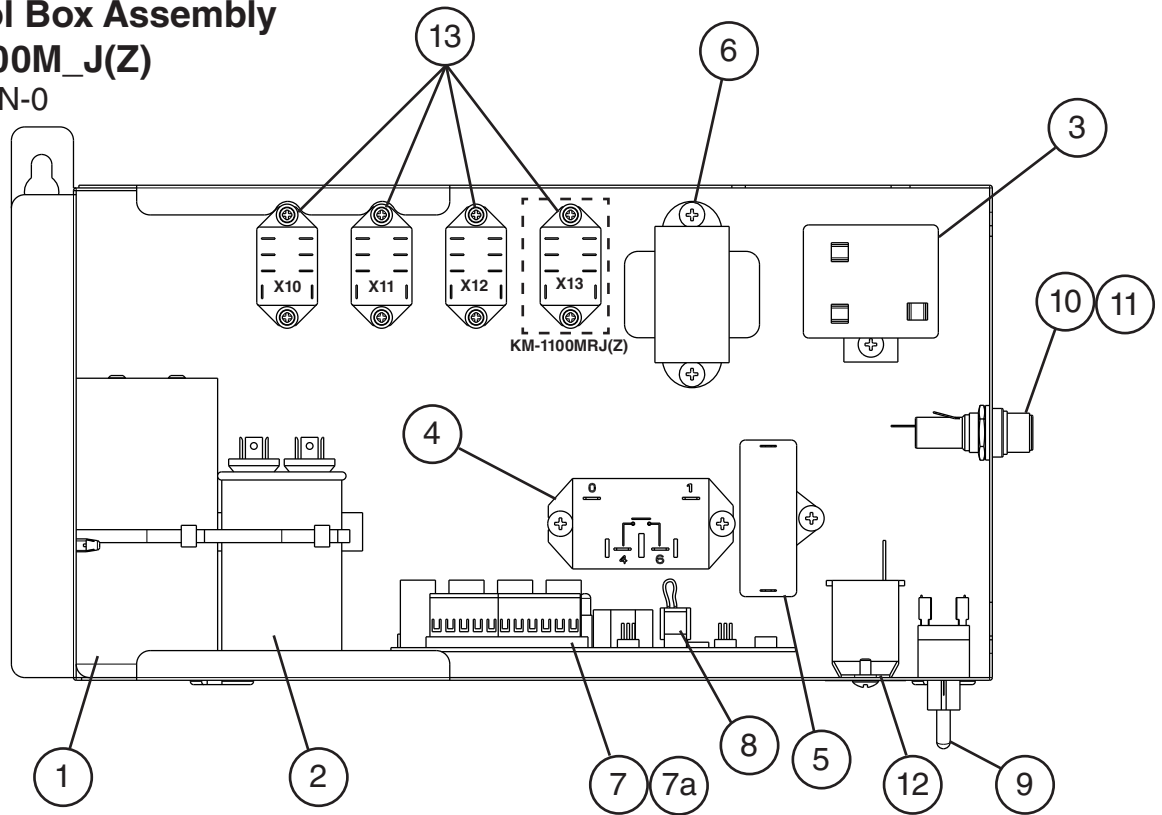

Title: C. Control Box Assembly    Model: KM-1100M_J(Z)				Required Number								
Index No.	Description	Material or Model Number	Part Number	G-0	G-1 to L-4	M-0	N-0					
1	Start Capacitor	145-174MFD, 220VAC	3A0076-11	1	1	1						
2	Run Capacitor	30MFD, 370VAC	3A2005-03	1	1	1						
3	Start Relay		4A1107-13	1	1	1						
4	Compressor Relay		4A3140-01	1	1	1						
5	Pump Motor Capacitor	10MFD, 250VAC	4A6435-01	1	1	1						
6	Control Transformer		3A0172-01	1	1	1						
7	Control Board		2A7664-01	1	-							
			2A7664-04		1	1						
7a	Control Board Support		4A0336-03	4	4	4						
8	K4 Jumper		4A4883G01	1	1	1						
9	Control Switch		443119-01	1	1	1						
10	Fuse Holder		4A5443-01	1	1	-						
	In-Line Fuse Holder (not shown)		4A6950-01			1						
11	Fuse	AGC-10, 250VAC, 10A	4A0893-07	1	1	1						
12	Bin Control Thermostat		4A2879-02	1	1	-						
13	Relay (X10 - Pump Motor Relay X11 - Control Relay X12 - Slush Control)	<b>All Models</b>	406132-07	3	3	3						
	Relay (X13 - Crankcase Heater)	<b>KM-1100MRJ(Z)</b>		1	1	1						

## D. Accessories & Labels

### KM-1100M\_J(Z)

G-0 to N-0

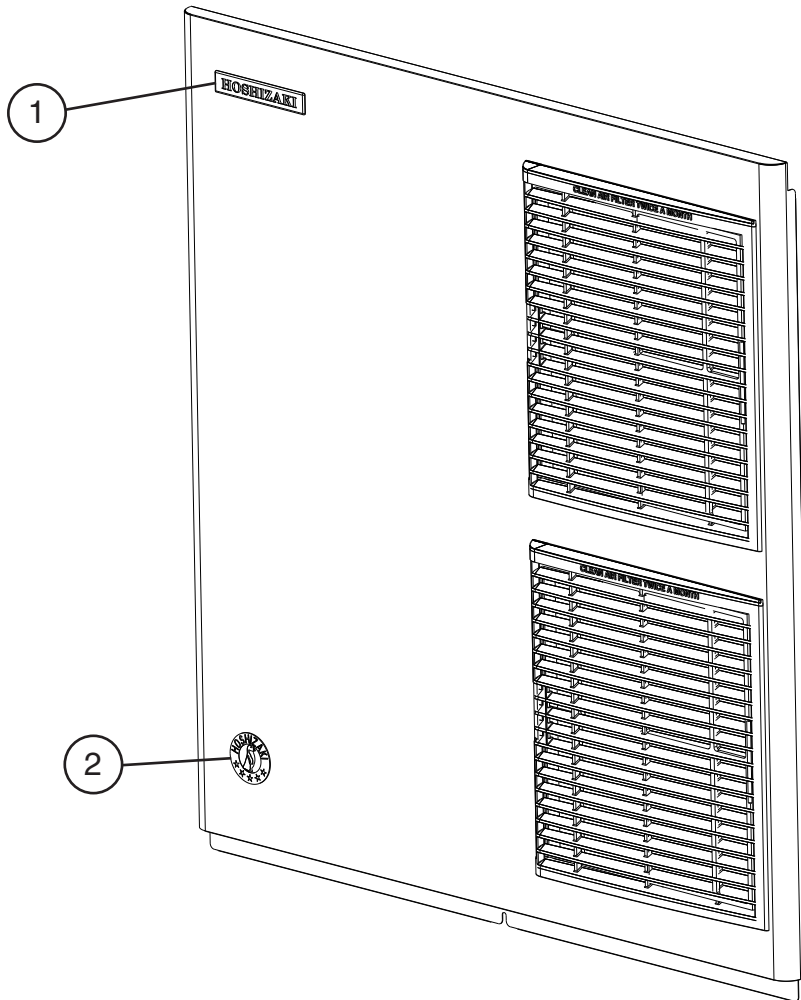

Title: D. Accessories & Labels    Model: KM-1100M_J(Z)										
Index No.	Description	Material or Model Number	Part Number	Required Number						
				G-0 to N-0						
1	Hoshizaki Emblem Label		4A0560-01	1						
2	Penguin Label		475552L02	1						
3	Universal Brace		4A0363-01	2						
3a	Hex Head Bolt		7B02-0512	2						