

Hoshizaki America, Inc.

Stackable Crescent Cuber

Models

KM-130ISAH/3

KM-130ISWH/3

KM-130ISRH/3



“A Superior Degree
of Reliability”

www.hoshizaki.com

INSTRUCTION MANUAL



Issued: 9-4-2008
Revised: 2-5-2013

IMPORTANT

Only qualified service technicians should attempt to install, service, or maintain this icemaker. No installation, service, or maintenance should be undertaken until the technician has thoroughly read this Instruction Manual. Likewise, the owner/manager should not proceed to operate the icemaker until the installer has instructed them on its proper operation. Failure to install, operate, and maintain the equipment in accordance with this manual may adversely affect safety, performance, and warranty coverage.

Hoshizaki provides this manual primarily to assist qualified service technicians in the installation, maintenance, and service of the icemaker.

Should the reader have any questions or concerns which have not been satisfactorily addressed, please call, write, or send an e-mail message to the Hoshizaki Technical Support Department for assistance.

HOSHIZAKI AMERICA, INC.
618 Highway 74 South
Peachtree City, GA 30269

Attn: Hoshizaki Technical Support Department

Phone: 1-800-233-1940 Technical Service
(770) 487-2331

Fax: 1-800-843-1056
(770) 487-3360

E-mail: techsupport@hoshizaki.com

Web Site: www.hoshizaki.com

NOTE: To expedite assistance, all correspondence/communication **MUST** include the following information:

- Model Number _____
- Serial Number _____
- Complete and detailed explanation of the problem.

IMPORTANT

This manual should be read carefully before the icemaker is installed and operated. Only qualified service technicians should install, service, and maintain the icemaker. Read the warnings contained in this booklet carefully as they give important information regarding safety. Please retain this booklet for any further reference that may be necessary.

CONTENTS

I. Specifications.....	4
A. Nameplate Rating	4
1. KM-1301SAH (air-cooled).....	4
2. KM-1301SAH3 (air-cooled)	5
3. KM-1301SWH (water-cooled)	6
4. KM-1301SWH3 (water-cooled)	7
5. KM-1301SRH (remote air-cooled).....	8
6. KM-1301SRH3 (remote air-cooled).....	9
B. Dimensions/Connections	10
1. KM-1301SAH/3.....	10
2. KM-1301SWH/3.....	11
3. KM-1301SRH/3.....	12
II. Installation and Operating Instructions	13
A. Checks Before Installation.....	13
B. How to Remove Panels	13
C. Location	14
D. Setup.....	14
E. Installation of Second Unit	16
F. Electrical Connection	18
G. Installation of Remote Condenser Unit	19
1. Checks Before Installation.....	19
2. Location	19
3. Setup	20
4. Line Set	20
5. Electrical Connection.....	22
6. Stacking Remote Condenser Unit	23
H. Water Supply and Drain Connections	23
I. Final Checklist	27
J. Startup	28
III. Cleaning and Maintenance	29
A. Cleaning and Sanitizing Instructions	29
1. Cleaning Procedure.....	30
2. Sanitizing Procedure - Following Cleaning Procedure	31
B. Maintenance Instructions	32
C. Preparing the Icemaker for Long Storage	32

I. Specifications

A. Nameplate Rating

1. KM-1301SAH (air-cooled)

HOSHIZAKI ICE MAKER

MODEL NUMBER	KM-1301SAH
SERIAL NUMBER	
AC SUPPLY VOLTAGE	208-230/60/1 (3 WIRE WITH NEUTRAL FOR 115V)
COMPRESSOR	208-230V 10.0RLA 61LRA
PUMP	120V 1.2FLA 60W
FAN	115V 0.85FLA 50W
OTHER	115-120V 0.3A
MAXIMUM FUSE SIZE	20 AMPS
MAX. HACR BREAKER (USA ONLY)	20 AMPS
MAX. CIRC. BREAKER (CANADA ONLY)	20 AMPS
MINIMUM CIRCUIT AMPACITY	20 AMPS
DESIGN PRESSURE	HI-467PSI LO-230PSI
REFRIGERANT	404A 3 LBS. 15.4 OZ.

**MOTOR-COMPRESSOR THERMALLY PROTECTED,
NOT INTENDED FOR OUTDOOR USE!**

Hoshizaki America, Inc.
Peachtree City, GA
www.hoshizaki.com

For certification marks, see the nameplate
on the rear panel.

See the nameplate for electrical and refrigeration specifications. This nameplate is located on the rear panel.

Since this nameplate is located on the rear panel of the icemaker, it cannot be read when the back of the icemaker is against a wall or against another piece of kitchen equipment. Therefore, the necessary electrical and refrigeration information is also on the rating label, which can be easily seen by removing only the front panel of the icemaker.

We reserve the right to make changes in specifications and design without prior notice.

2. KM-1301SAH3 (air-cooled)

HOSHIZAKI ICE MAKER

MODEL NUMBER	KM-1301SAH3
SERIAL NUMBER	
AC SUPPLY VOLTAGE	208-230/60/3
COMPRESSOR	208-230V 7.1RLA 55LRA
PUMP	120V 1.2FLA 60W
FAN	115V 0.85FLA 50W
OTHER	115-120V 0.3A
MAXIMUM FUSE SIZE	20 AMPS
MAX. HACR BREAKER (USA ONLY)	20 AMPS
MAX. CIRC. BREAKER (CANADA ONLY)	20 AMPS
MINIMUM CIRCUIT AMPACITY	20 AMPS
DESIGN PRESSURE	HI-467PSI LO-230PSI
REFRIGERANT	404A 3 LBS. 15.4 OZ.

**MOTOR-COMPRESSOR THERMALLY PROTECTED,
NOT INTENDED FOR OUTDOOR USE!**

Hoshizaki America, Inc.
Peachtree City, GA
www.hoshizaki.com

For certification marks, see the nameplate
on the rear panel.

See the nameplate for electrical and refrigeration specifications. This nameplate is located on the rear panel.

Since this nameplate is located on the rear panel of the icemaker, it cannot be read when the back of the icemaker is against a wall or against another piece of kitchen equipment. Therefore, the necessary electrical and refrigeration information is also on the rating label, which can be easily seen by removing only the front panel of the icemaker.

We reserve the right to make changes in specifications and design without prior notice.

3. KM-1301SWH (water-cooled)

HOSHIZAKI ICE MAKER	
MODEL NUMBER	KM-1301SWH
SERIAL NUMBER	
AC SUPPLY VOLTAGE	208-230/60/1 (3 WIRE WITH NEUTRAL FOR 115V)
COMPRESSOR	208-230V 8.2RLA 56LRA
PUMP	120V 1.2FLA 60W
FAN	--- --- ---
OTHER	115-120V 0.3A
MAXIMUM FUSE SIZE	20 AMPS
MAX. HACR BREAKER (USA ONLY)	20 AMPS
MAX. CIRC. BREAKER (CANADA ONLY)	20 AMPS
MINIMUM CIRCUIT AMPACITY	20 AMPS
DESIGN PRESSURE	HI-427PSI LO-230PSI
REFRIGERANT	404A 2 LBS. 8.2 OZ.

**MOTOR-COMPRESSOR THERMALLY PROTECTED,
NOT INTENDED FOR OUTDOOR USE!**

Hoshizaki America, Inc.
Peachtree City, GA
www.hoshizaki.com

For certification marks, see the nameplate
on the rear panel.

See the nameplate for electrical and refrigeration specifications. This nameplate is located on the rear panel.

Since this nameplate is located on the rear panel of the icemaker, it cannot be read when the back of the icemaker is against a wall or against another piece of kitchen equipment. Therefore, the necessary electrical and refrigeration information is also on the rating label, which can be easily seen by removing only the front panel of the icemaker.

We reserve the right to make changes in specifications and design without prior notice.

4. KM-1301SWH3 (water-cooled)

HOSHIZAKI ICE MAKER

MODEL NUMBER	KM-1301SWH3
SERIAL NUMBER	
AC SUPPLY VOLTAGE	208-230/60/3
COMPRESSOR	208-230V 6.1RLA 51LRA
PUMP	120V 1.2FLA 60W
FAN	--- --- ---
OTHER	115-120V 0.3A
MAXIMUM FUSE SIZE	20 AMPS
MAX. HACR BREAKER (USA ONLY)	20 AMPS
MAX. CIRC. BREAKER (CANADA ONLY)	20 AMPS
MINIMUM CIRCUIT AMPACITY	20 AMPS
DESIGN PRESSURE	HI-427PSI LO-230PSI
REFRIGERANT	404A 2 LBS. 8.2 OZ.

**MOTOR-COMPRESSOR THERMALLY PROTECTED,
NOT INTENDED FOR OUTDOOR USE!**

Hoshizaki America, Inc.
Peachtree City, GA
www.hoshizaki.com

For certification marks, see the nameplate
on the rear panel.

See the nameplate for electrical and refrigeration specifications. This nameplate is located on the rear panel.

Since this nameplate is located on the rear panel of the icemaker, it cannot be read when the back of the icemaker is against a wall or against another piece of kitchen equipment. Therefore, the necessary electrical and refrigeration information is also on the rating label, which can be easily seen by removing only the front panel of the icemaker.

We reserve the right to make changes in specifications and design without prior notice.

5. KM-1301SRH (remote air-cooled)

HOSHIZAKI ICE MAKER

MODEL NUMBER	KM-1301SRH
SERIAL NUMBER	
AC SUPPLY VOLTAGE	208-230/60/1 (3 WIRE WITH NEUTRAL FOR 115V)
COMPRESSOR	208-230V 9.3RLA 56LRA
PUMP	120V 1.2FLA 60W
FAN REMOTE	120V 3A MAX
OTHER	115-120V 0.3A
MAXIMUM FUSE SIZE	20 AMPS
MAX. HACR BREAKER (USA ONLY)	20 AMPS
MAX. CIRC. BREAKER (CANADA ONLY)	20 AMPS
MINIMUM CIRCUIT AMPACITY	20 AMPS
DESIGN PRESSURE	HI-467PSI LO-230PSI
REFRIGERANT	404A

**MOTOR-COMPRESSOR THERMALLY PROTECTED,
NOT INTENDED FOR OUTDOOR USE!**

Hoshizaki America, Inc.
Peachtree City, GA
www.hoshizaki.com

For certification marks, see the nameplate
on the rear panel.

See the nameplate for electrical and refrigeration specifications. This nameplate is located on the rear panel.

Since this nameplate is located on the rear panel of the icemaker, it cannot be read when the back of the icemaker is against a wall or against another piece of kitchen equipment. Therefore, the necessary electrical and refrigeration information is also on the rating label, which can be easily seen by removing only the front panel of the icemaker.

We reserve the right to make changes in specifications and design without prior notice.

6. KM-1301SRH3 (remote air-cooled)

HOSHIZAKI ICE MAKER	
MODEL NUMBER	KM-1301SRH3
SERIAL NUMBER	
AC SUPPLY VOLTAGE	208-230/60/3
COMPRESSOR	208-230V 6.2RLA 51LRA
PUMP	120V 1.2FLA 60W
FAN REMOTE	120V 3A MAX
OTHER	115-120V 0.3A
MAXIMUM FUSE SIZE	20 AMPS
MAX. HACR BREAKER (USA ONLY)	20 AMPS
MAX. CIRC. BREAKER (CANADA ONLY)	20 AMPS
MINIMUM CIRCUIT AMPACITY	20 AMPS
DESIGN PRESSURE	HI-467PSI LO-230PSI
REFRIGERANT	404A

**MOTOR-COMPRESSOR THERMALLY PROTECTED,
NOT INTENDED FOR OUTDOOR USE!**

Hoshizaki America, Inc.
Peachtree City, GA
www.hoshizaki.com

For certification marks, see the nameplate
on the rear panel.

See the nameplate for electrical and refrigeration specifications. This nameplate is located on the rear panel.

Since this nameplate is located on the rear panel of the icemaker, it cannot be read when the back of the icemaker is against a wall or against another piece of kitchen equipment. Therefore, the necessary electrical and refrigeration information is also on the rating label, which can be easily seen by removing only the front panel of the icemaker.

We reserve the right to make changes in specifications and design without prior notice.

B. Dimensions/Connections

1. KM-1301SAH/3

Unit: (mm) inches

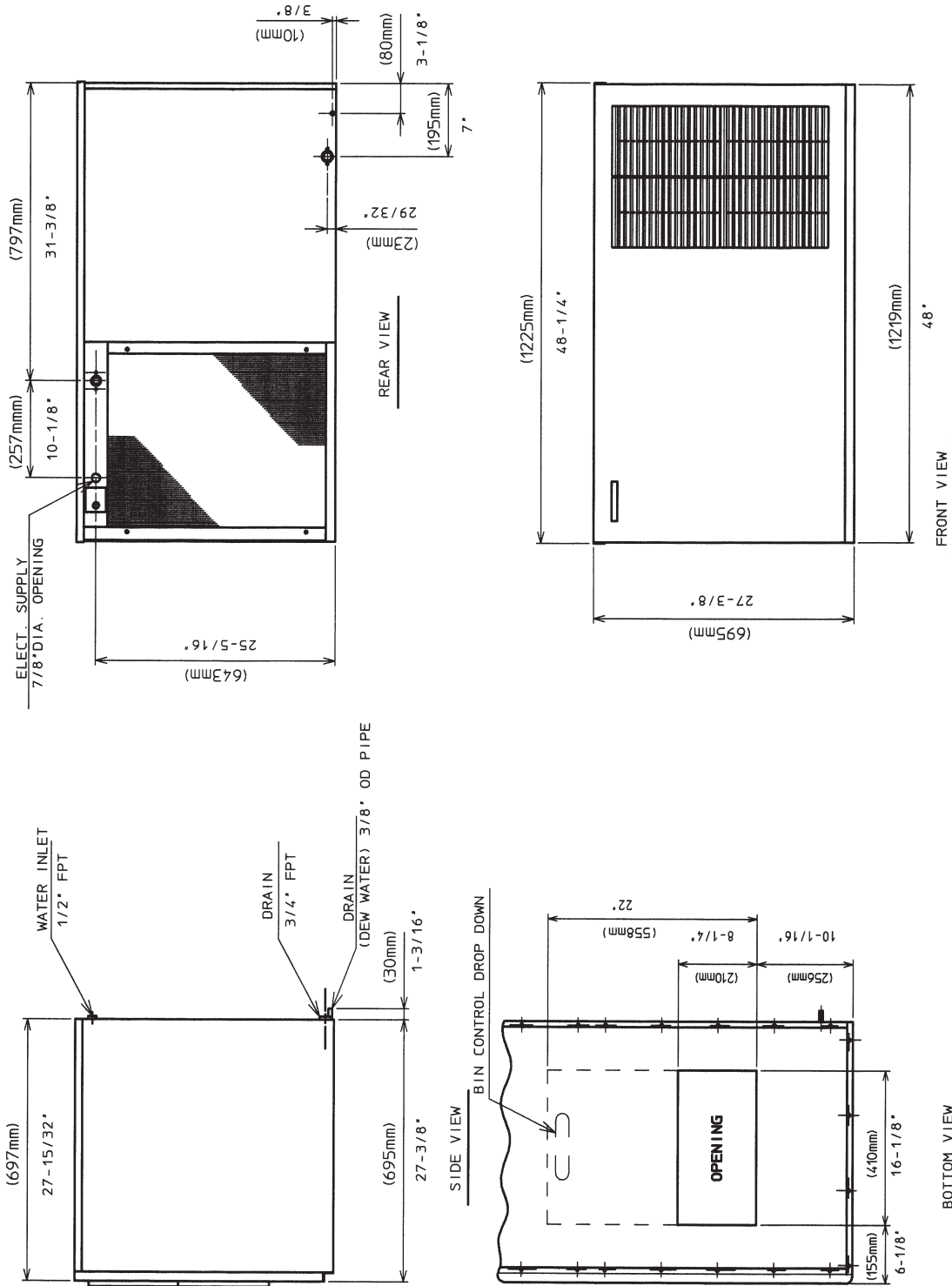

Note: When used with a storage bin not recommended by Hoshizaki, the icemaker needs the space at the bottom opening as in the illustration.

2. KM-1301SWH/3

Unit: (mm) inches

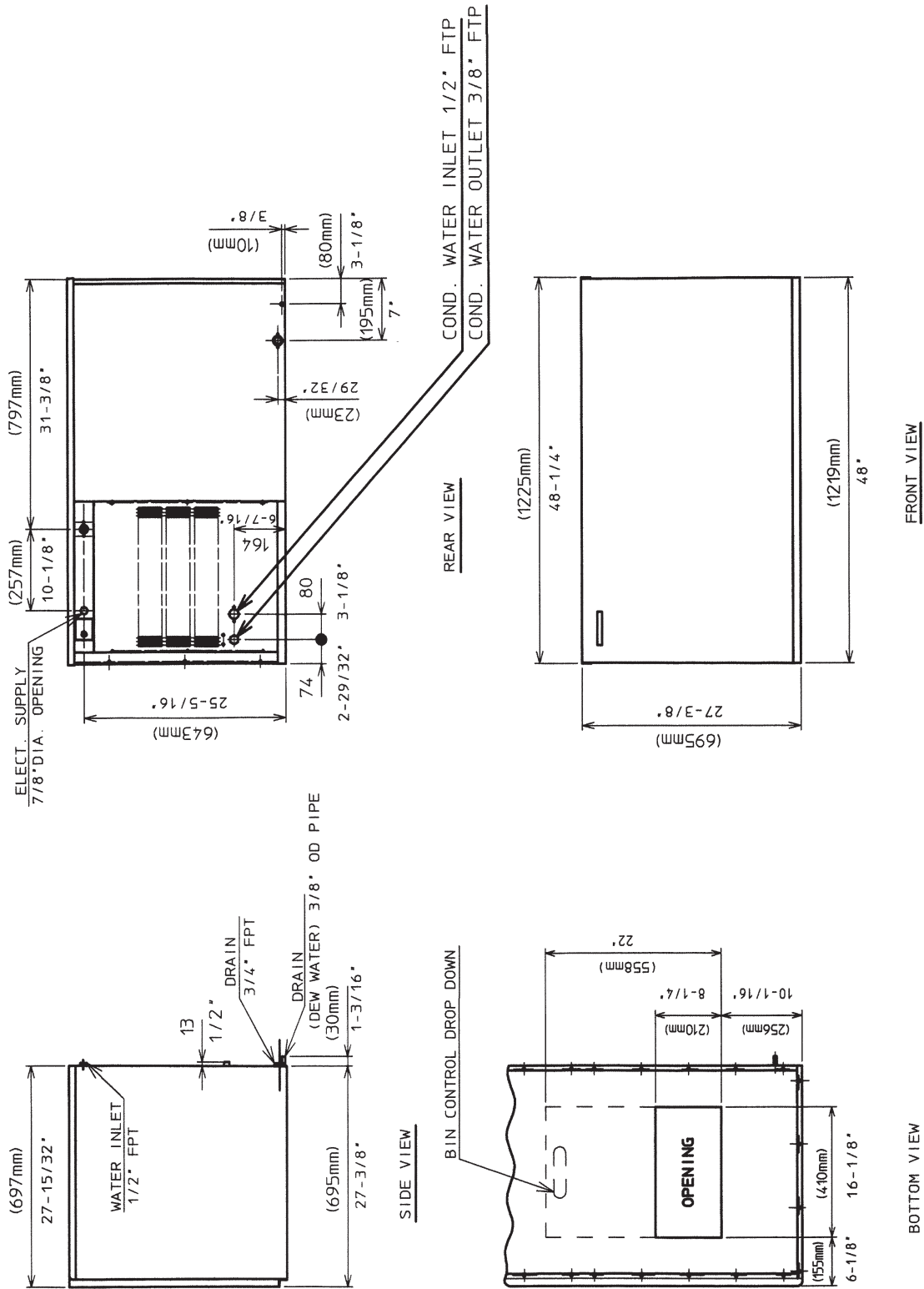

Note: When used with a storage bin not recommended by Hoshizaki, the icemaker needs the space at the bottom opening as in the illustration.

3. KM-1301SRH/3

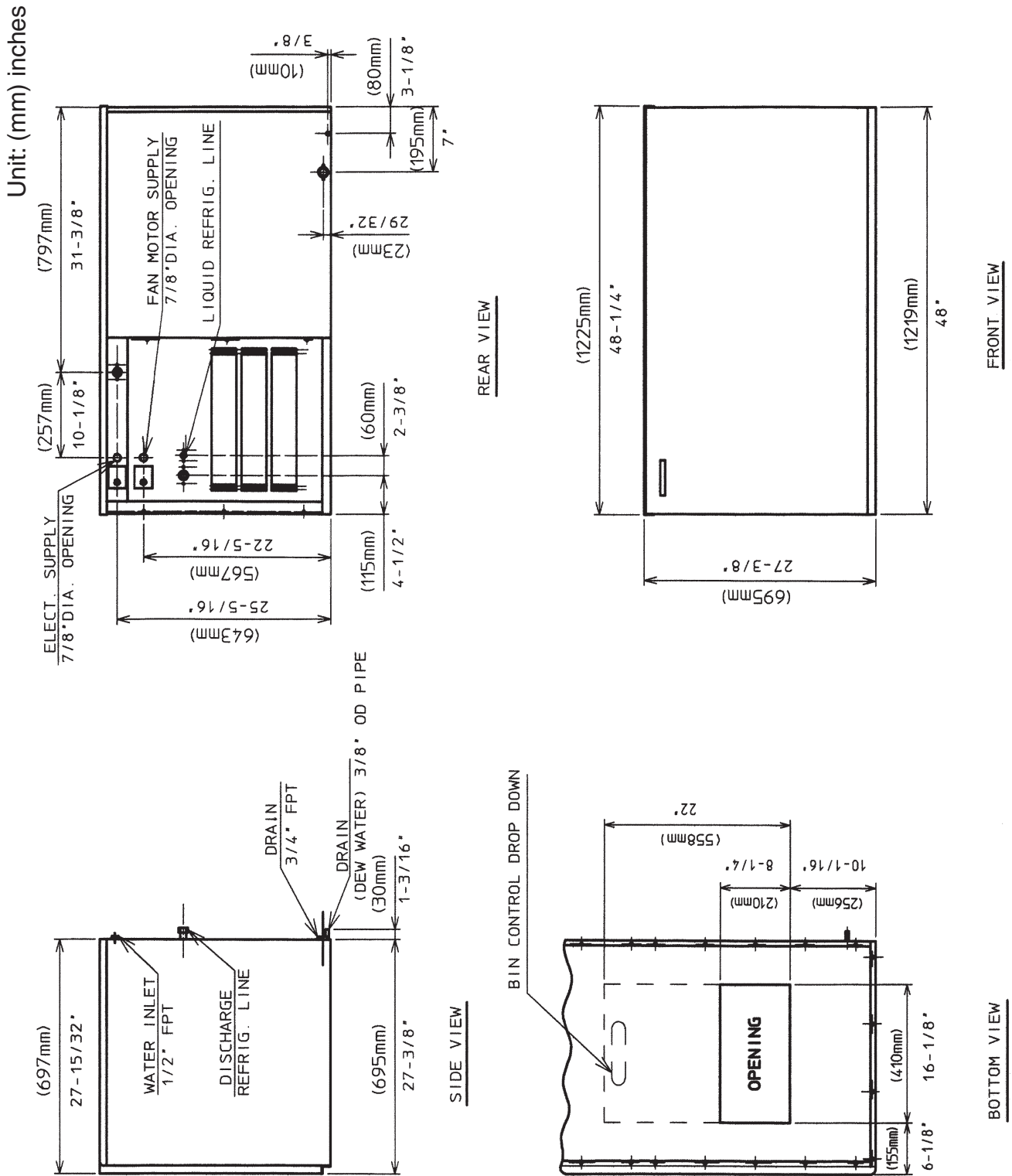

Note: When used with a storage bin not recommended by Hoshizaki, the icemaker needs the space at the bottom opening as in the illustration.

II. Installation and Operating Instructions

A. Checks Before Installation

IMPORTANT

1. Install in accordance with all applicable national, state, and local regulations.
2. Remove the shipping carton, tape, and packing material. If any are left in the icemaker, it will not work properly.
3. Ensure all components, fasteners, and thumbscrews are securely in place after installation.

- 1) Remove the panels to prevent damage when installing the icemaker. See "II.B. How to Remove Panels."
- 2) Remove the package containing the accessories.
- 3) Remove the protective plastic film from the panels. If the icemaker is exposed to the sun or to heat, remove the film after the icemaker cools.
- 4) Check that the refrigerant lines do not rub or touch lines or other surfaces, and that the fan blade turns freely.
- 5) Check that the compressor is snug on all mounting pads.
- 6) See the nameplate on the rear panel, and check that your voltage supplied corresponds with the voltage specified on the nameplate.
- 7) This icemaker needs a storage bin. The recommended storage bin is Hoshizaki Ice Storage Bin, Model B-800 series.
- 8) On remote air-cooled models, a remote condenser unit is needed. The recommended remote condenser unit is Hoshizaki Remote Condenser Unit, Model URC-14F.

B. How to Remove Panels

See Fig. 1

- Front Panel: Remove the 2 screws. Lift up and towards you.
- Top Panel: Remove the 2 screws, and then lift off.
- Side Panel (R): Remove the screw. Slide forward slightly and lift off.
- Insulation Panel: Remove the thumbscrew. Lift up slightly and pull towards you.

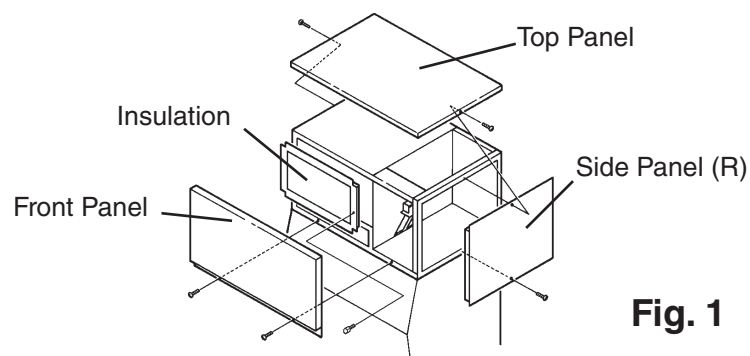

Fig. 1

C. Location

CAUTION

1. This icemaker is not intended for outdoor use. Normal operating ambient temperature should be within +45°F to +100°F (+7°C to +38°C); Normal operating water temperature should be within +45°F to +90°F (+7°C to +32°C). Operation of the icemaker, for extended periods, outside of these normal temperature ranges may affect icemaker performance.
2. This icemaker will not work at sub-freezing temperatures. To prevent damage to the water supply line, drain the icemaker if the air temperature is going to go below 32°F (0°C). See "III.C. Preparing the Icemaker for Long Storage."

For best operating results:

- Icemaker should not be located next to ovens, grills, or other high heat producing equipment.
- Avoid choosing a site where dripping is not allowed.
- Allow 6" (15 cm) clearance at rear, sides, and top for proper air circulation and ease of maintenance and/or service should they be required.
- Location should provide a firm, level foundation for the equipment.

D. Setup

CAUTION

Before operating the icemaker, the bin control thermostat assembly must be installed correctly. Failure to properly install the assembly could result in ice backup and unit damage.

- 1) Unpack the storage bin and attach the 4 adjustable legs provided (bin accessory) to the bottom of the storage bin.
- 2) Position the storage bin in the selected permanent location.
- 3) Place the icemaker on top of the storage bin.
- 4) Secure the icemaker to the storage bin using the 2 mounting brackets and the bolts provided. See Fig. 2.

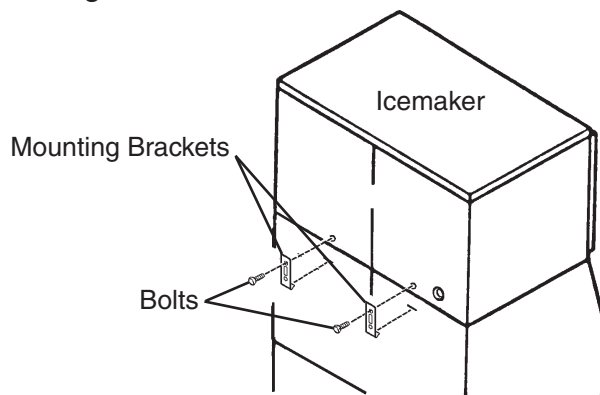

Fig. 2

- 5) Install the bin control thermostat as follows:
 - a. Remove the baffle from the bin.
 - b. Remove the tie securing the bin control thermostat assembly. Remove the 2 thumbscrews.
 - c. Remove the bin control thermostat assembly from the shipping hook by lifting it up and shifting it to the right. Lower the thermostat extension bracket (stainless) with the thermostat bulb attachment and thermostat bulb through the hole located at the bottom of the icemaker. Next, lower the thermostat bracket (plastic) through the hole.

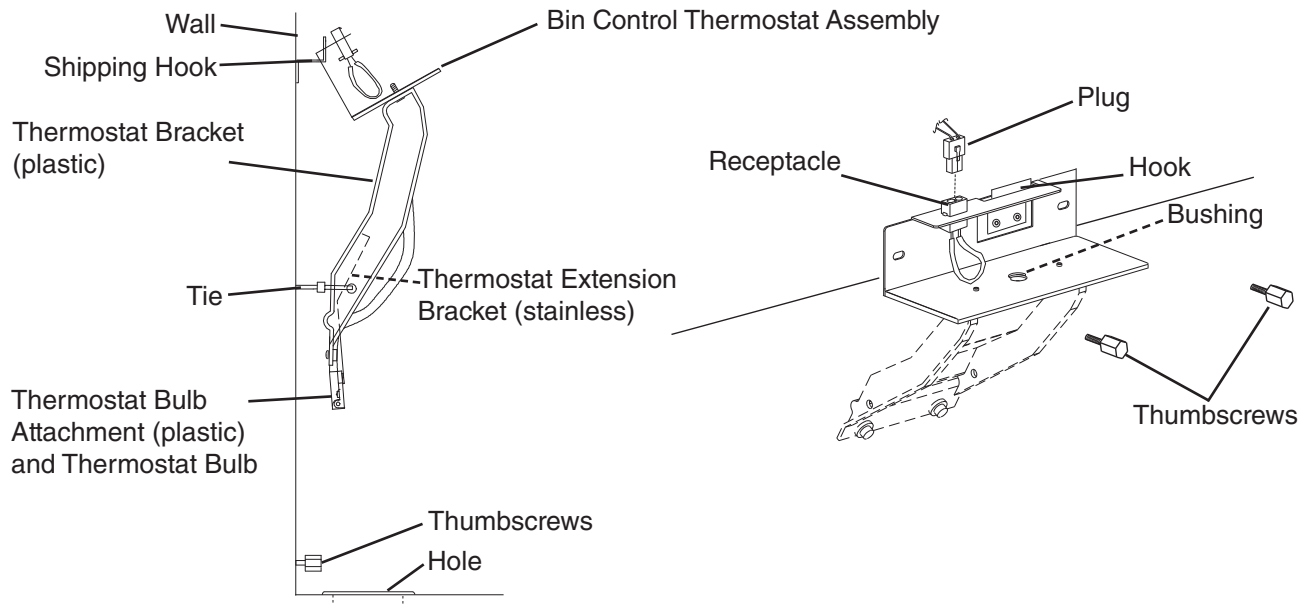

Fig. 3

- d. Make sure the left side and bottom of the assembly are flush against the wall and base panel.
- e. Secure the assembly into place with the thumbscrews (unless you are installing a second unit). (See "II.E. Installation of Second Unit.")
- f. Insert the plug into the receptacle on the assembly until it locks into place.
- g. Remove the 2 screws from the lower part of the thermostat bracket (plastic) and use them to attach the thermostat extension bracket (stainless) to the thermostat bracket (plastic).

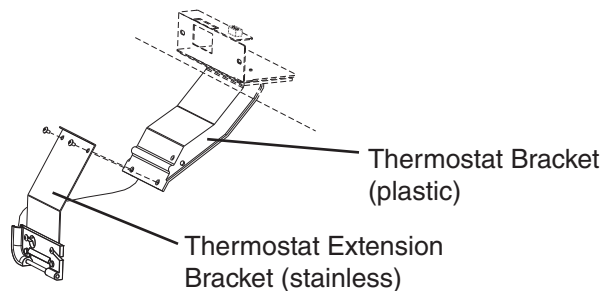

Fig. 4

- 6) Level the icemaker and storage bin in both the left-to-right and front-to-rear directions. Adjust the storage bin legs to make the icemaker level.
- 7) Replace the panels and baffle in their correct positions (unless you are installing a second unit). (See "II.E. Installation of Second Unit.")

E. Installation of Second Unit

- 1) See "II.D. Setup" for the lower unit installation.
- 2) Remove the top panel and the top insulation of the lower unit. The top panel and the top insulation of the lower unit are not required when installing the second icemaker.
- 3) Unpack the second icemaker (upper unit), and remove the shipping carton, tape, and packing material.
- 4) Remove the panels of the second icemaker.
- 5) Stack the upper unit on top of the lower unit.
- 6) Secure the upper unit to the lower unit using the 2 mounting brackets and the bolts provided.

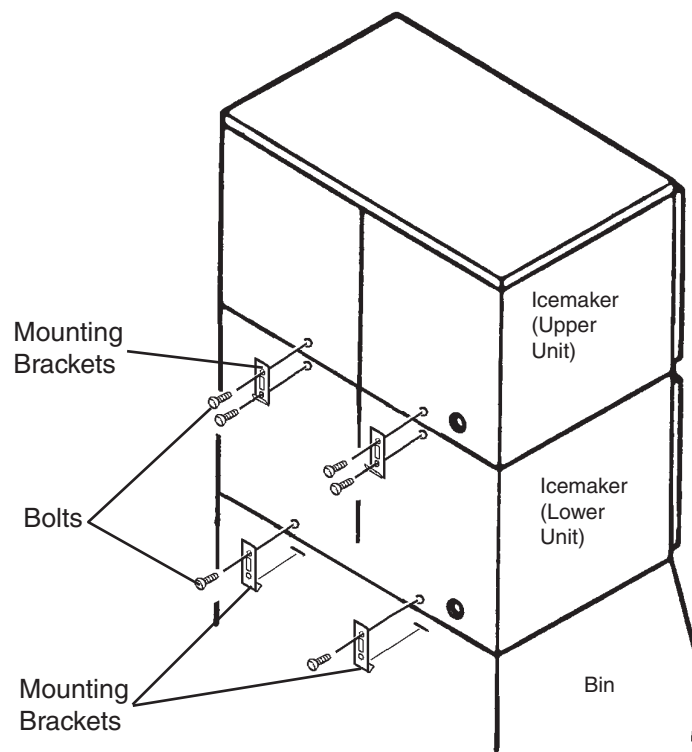

Fig. 5

- 7) Remove the tie securing the upper unit's bin control thermostat assembly.
- 8) Remove the bin control thermostat assembly from the shipping hook by lifting it up and shifting it to the right.
- 9) Remove the thermostat bulb attachment (plastic) of the upper unit from the thermostat extension bracket (stainless).
- 10) Carefully remove the thermostat bulb from the thermostat bulb attachment (plastic) of the upper unit.
- 11) Carefully route the thermostat bulb and capillary tubing of the upper unit through the bottom hole of the upper unit. Remove the bushing from the lower bin control thermostat assembly. Route the bulb and tubing through the hole in the assembly and down into the bin. Reattach the bushing.
- 12) Secure the lower bin control thermostat assembly in place with the thumbscrews.
- 13) Carefully insert the thermostat bulb back into the thermostat bulb attachment (plastic).
- 14) Secure the thermostat bulb attachment (plastic) of the upper unit to the thermostat bulb attachment (plastic) of the lower unit with the screws of the upper unit.
- 15) Insert the plug of the upper unit into the receptacle of the upper unit's bin control thermostat assembly until it locks into place.
- 16) Replace the panels and baffle in their correct positions.

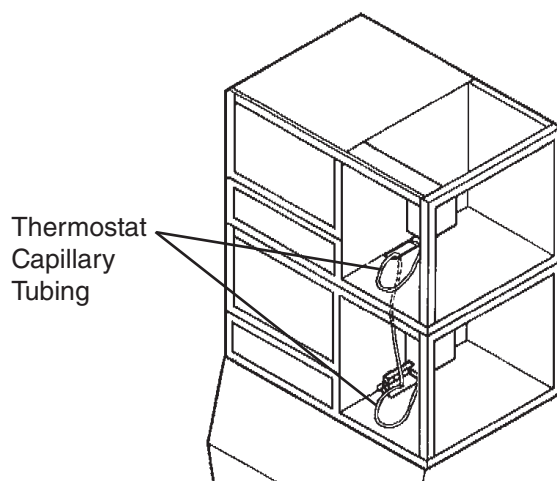

Fig. 6

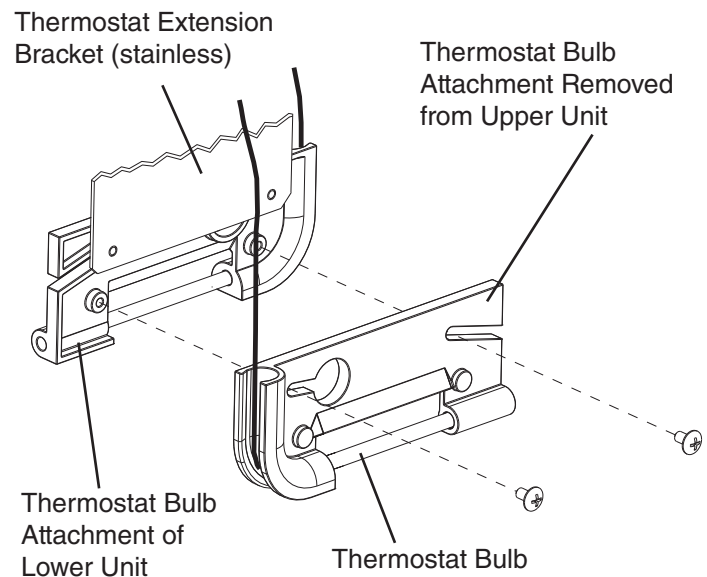

Fig. 7

F. Electrical Connection

WARNING

1. Electrical connections must be made in accordance with the instructions on the "WARNING" tag, provided with the pig tail leads in the junction box.
2. Electrical connections must meet national, state, and local electrical code requirements. Failure to meet these code requirements could cause severe injury to individuals or extensive damage to equipment.
3. Be sure to install a proper ground to the icemaker.
4. When installing a remote air-cooled model, the power supply and ground wire to the condenser unit are supplied from the icemaker. See "II.G.5. Electrical Connection."
5. To reduce the risk of electric shock, do not connect the power supply until after all condenser unit connections have been made.
6. On remote air-cooled model, the icemaker should have power for a minimum of 4 hours prior to startup to prevent compressor damage.

- Electrical connections must be installed in accordance with applicable national, state, and local regulations.
- Usually an electrical permit and services of a licensed electrician are required.
- The icemaker requires an independent power supply. See the nameplate for proper voltage and breaker/fuse size.
- The maximum allowable voltage variation is ± 10 percent of the nameplate rating.
- On single phase models only, the white lead must be connected to the neutral conductor of the power source. Miswiring results in severe damage to the icemaker. See Fig. 8a.
- On three phase models, the transformer's voltage tap switch should be positioned to match incoming voltage at startup. See Fig. 8b.
- The opening for the power supply connection is 7/8" DIA to fit a 1/2" trade size conduit.

KM-1301S_H

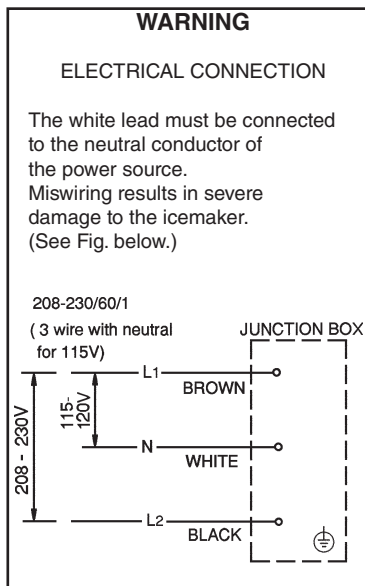

Fig. 8a

KM-1301S_H3

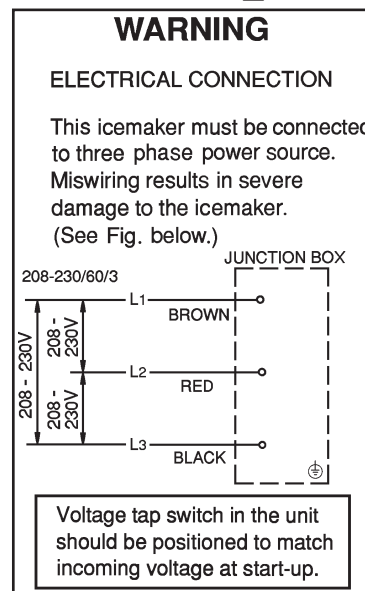

Fig. 8b

G. Installation of Remote Condenser Unit

1. Checks Before Installation

- 1) Remove the shipping carton, tape, and packing material.
- 2) Check that the refrigerant lines do not rub or touch lines or other surfaces, and that the fan blades move freely.

2. Location

IMPORTANT

The remote condenser unit is intended for outdoor use. Normal operating ambient temperature should be within -20°F to +122°F (-29°C to +50°C). Operation of the remote condenser unit, for extended periods, outside of this normal temperature range may affect icemaker performance.

The remote condenser unit must be positioned in a permanent site under the following guidelines:

- A firm and flat site.
- A dry and well ventilated area with 24" (61 cm) clearance in both front and rear for ease of maintenance and service should they be required.
- The maximum line length for the standard refrigerant charge is 66 feet. Should an installation require a longer line length, additional refrigerant must be added. Add .4 oz. of R-404A for each foot over 66 feet to a maximum of 100 feet or contact Hoshizaki Technical Support at 1-800-233-1940 for recommendations.
- The maximum vertical distance between the remote condenser unit and the icemaker is 33 feet above or 10 feet below the icemaker. These distances are measured fitting to fitting.

CAUTION

Failure to install the equipment within these guidelines may adversely affect performance, component life, and warranty coverage.

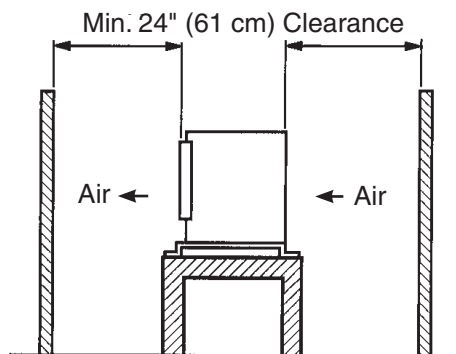

Fig. 9

3. Setup

- 1) Secure the legs to the remote condenser unit with eight M8×16 mm hexagon bolts and M8 nuts as shown in the illustration. See Fig. 10.
- 2) The legs have eight mounting holes. Secure the legs with eight bolts (not included).

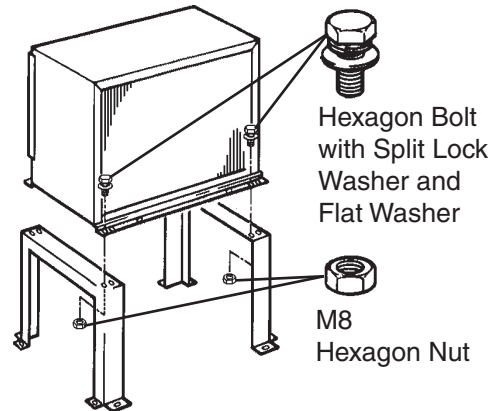

Fig. 10

4. Line Set

- Precharged tubing kits, available as optional equipment from Hoshizaki America, are recommended. Field fabricated line sets are allowed, see instructions below.
- The maximum line length for the standard refrigerant charge is 66 feet. Should an installation require a longer line length, additional refrigerant must be added. Add .4 oz. of R-404A for each foot over 66 feet to a maximum of 100 feet or contact Hoshizaki Technical Support at 1-800-233-1940 for recommendations.
- The maximum vertical distance between the remote condenser unit and the icemaker is 33 feet above or 10 feet below the icemaker. These distances are measured fitting to fitting.

CAUTION

Failure to install the equipment within these guidelines may adversely affect performance, component life, and warranty coverage.

Factory Line Set Installation

- 1) Route the factory line set (1/2" OD discharge line and 3/8" OD liquid line) from the remote condenser unit to the icemaker. See Fig. 11. Factory fabricated line sets are precharged and do not need to be evacuated.

Note: Care should be taken that the icemaker, line set, and remote condenser unit contain the same type of refrigerant prior to making connections. Mixing of refrigerants will result in improper operation and possible damage to the refrigeration system.

- 2) Attach the refrigerant lines to the appropriate male couplings on the remote condenser unit first and then at the icemaker. Apply two drops of POE oil to the male threads of the couplings before tightening.
- 3) Tighten the couplings 1/4 turn beyond fully seated. A backup wrench is recommended.

Field Fabricated Line Set Installation

- 1) Route a 1/2" OD copper tube discharge line and a 3/8" OD copper tube liquid line between the remote condenser unit and the icemaker. See Fig. 11.
- 2) Insulate the two copper tubes separately.
- 3) Install Parker quick connect couplings on each end. OS-QUICK, a universal quick connect coupling kit available as optional equipment from Hoshizaki America, is recommended.
- 4) Evacuate through the charging ports on the Parker quick connect couplings and charge with R-404A refrigerant vapor to a pressure of 15 to 30 PSIG.

Note: Care should be taken that the icemaker, line set, and remote condenser unit contain the same type of refrigerant prior to making connections. Mixing of refrigerants will result in improper operation and possible damage to the refrigeration system.

- 5) Attach the refrigerant lines to the appropriate male couplings on the remote condenser unit first and then at the icemaker. Apply two drops of POE oil to the male threads of the couplings before tightening.
- 6) Tighten the couplings 1/4 turn beyond fully seated. A backup wrench is recommended.

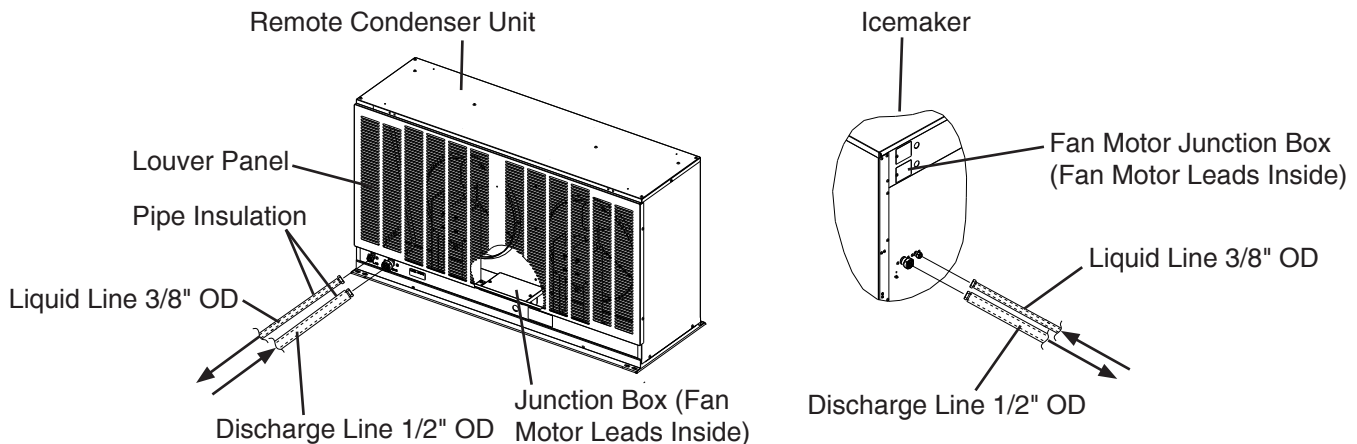

Fig. 11

5. Electrical Connection

WARNING

1. Electrical connections must meet national, state, and local electrical code requirements. Failure to meet these code requirements could cause severe injury to individuals or extensive damage to equipment.
2. Be sure to install a proper ground from the icemaker to the remote condenser unit.
3. To reduce the risk of electric shock, do not connect the power supply until after all condenser unit connections have been made.
4. On remote air-cooled model, the icemaker should have power for a minimum of 4 hours prior to startup to prevent compressor damage.

- This remote condenser unit must be connected to the fan motor junction box on the icemaker.
 - Usually an electrical permit and services of a licensed electrician are required.
 - Power supply and ground wire to the condenser unit are supplied from the icemaker. Connect the condenser unit and icemaker using appropriate outdoor-rated wire.
- 1) Remove the louver panel. See Fig. 12.
 - 2) Remove the junction box cover on the remote condenser unit. Remove the fan motor junction box cover on the icemaker.
 - 3) Install a ground wire from the icemaker to the remote condenser unit.
 - 4) Connect the fan motor leads in the junction box of the remote condenser unit to the fan motor leads in the fan motor junction box of the icemaker.
 - 5) Replace the junction box covers and the louver panel in their correct positions.

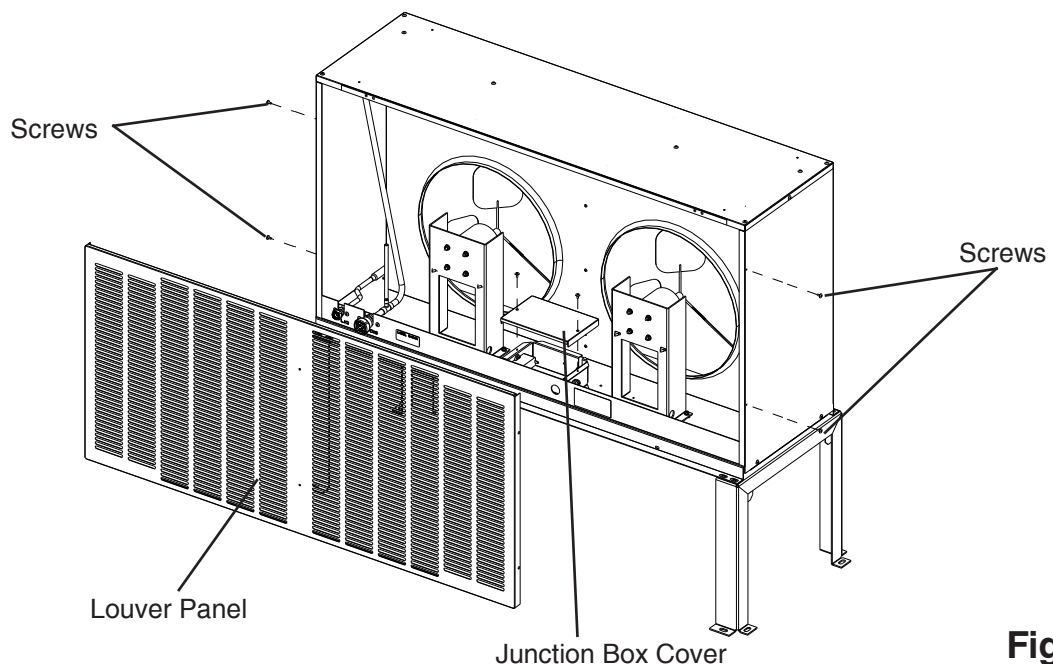

Fig. 12

6. Stacking Remote Condenser Unit

- 1) Install the lower remote condenser unit as described earlier in this section.
- 2) Place the upper remote condenser unit on top of the lower. See Fig. 13.
- 3) Secure the upper remote condenser unit with the 4 screws provided.
- 4) Install refrigerant lines, and make electrical connections for each fan motor as described earlier in this section.

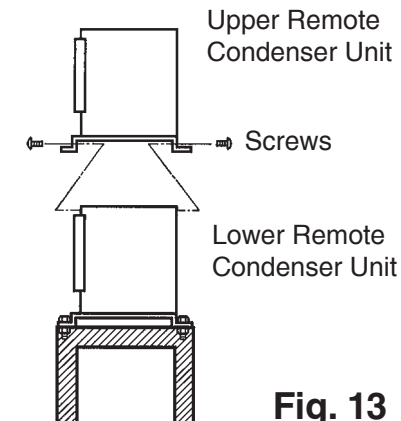

Fig. 13

H. Water Supply and Drain Connections

See Fig. 14, 15, or 16

CAUTION

1. Normal operating water temperature should be within +45 F to +90 F (+7°C to +32°C). Operation of the icemaker, for extended periods, outside of this normal temperature range may affect icemaker performance.
2. To prevent damage to equipment, do not operate the icemaker when the water supply is off, or if the pressure is below 10 PSIG. Do not run the icemaker until the proper water pressure is reached.

- Water supply and drain connections must be installed in accordance with applicable national, state, and local regulations.
- A plumbing permit and services of a licensed plumber may be required in some areas.
- External filters, strainers, or softeners may be required depending on water quality. Contact your local Hoshizaki distributor for recommendations.

1. Icemaker

- Water supply inlet is 1/2" female pipe thread (FPT). A minimum of 1/2" OD copper tubing is recommended for the water supply line.
- A water supply line shut-off valve and drain valve should be installed.
- Water supply pressure should be a minimum of 10 PSIG and a maximum of 113 PSIG. If the pressure exceeds 113 PSIG, the use of a pressure reducing valve is required.
- Icemaker drain outlet is 3/4" FPT. A minimum of 3/4" OD hard pipe is recommended for the icemaker drain line. The icemaker drain line must be run separately from the storage bin drain line.

- Condensation drain outlet is a 3/8" OD stainless tube. The icemaker and condensation drain line(s) must be run separately from the storage bin drain line.
- Drain lines must have 1/4" fall per foot (2 cm per 1 m) on horizontal runs to get a good flow. A vented tee connection is also required for proper flow.
- Drain lines should not be piped directly to the sewer system. An air gap of a minimum of 2 vertical inches (5 cm) should be between the end of the drain pipes from the icemaker, the condensation drain, the storage bin, and the water-cooled condenser (if applicable) and the floor drain.

2. Water-Cooled Condenser (if applicable)

a) Connection to a Potable Water Supply.

- Water supply inlet is 1/2" female pipe thread (FPT). A minimum of 3/8" OD copper tubing is recommended for the water supply line.
- A water supply line shut-off valve and drain valve should be installed.
- Water supply pressure should be a minimum of 10 PSIG and a maximum of 113 PSIG. If the pressure exceeds 113 PSIG, the use of a pressure reducing valve is required.
- Condenser drain outlet is 3/8" FPT. A minimum of 3/8" OD hard pipe is recommended for the condenser drain line. Drain line must be run separately.
- Drain line must have 1/4" fall per foot (2 cm per 1 m) on horizontal runs to get good flow. A vented tee connection is also required for proper flow.
- Drain line should not be piped directly to the sewer system. An air gap of a minimum of 2 vertical inches (5 cm) should be between the end of the drain pipe and the floor drain.
- In some areas, a back flow preventer may be required in the cooling water circuit.

b) Connection to a Closed Loop Water Supply.

- Water supply inlet is 1/2" female pipe thread (FPT). A minimum of 3/8" OD copper tubing is recommended for the water supply line.
- Condenser return outlet is 3/8" FPT. A minimum of 3/8" OD hard pipe is recommended for the condenser return line.
- Shut-off valves and drain valves should be installed at both the condenser inlet and condenser return outlet.
- Water supply pressure should be a minimum of 10 PSIG and a maximum of 113 PSIG. The water supply to the condenser should not drop below 4 GPM.
- The pressure differential between the inlet and outlet water lines must be no less than 10 PSIG.
- When using a glycol blend, the solution mixture should be less than 30% glycol.
- In order to maintain the proper high side pressure, the water inlet temperature should not drop below 45°F (7°C) and the water outlet temperature must be in the 104°F to 115°F (40°C to 46°C) range. Once the icemaker installation is complete, confirm the outlet temperature 5 minutes after a freeze cycle starts. If the outlet temperature is not in the proper range, adjust the water-regulating valve to bring it into range.

KM-1301SAH/3
KM-1301SRH/3

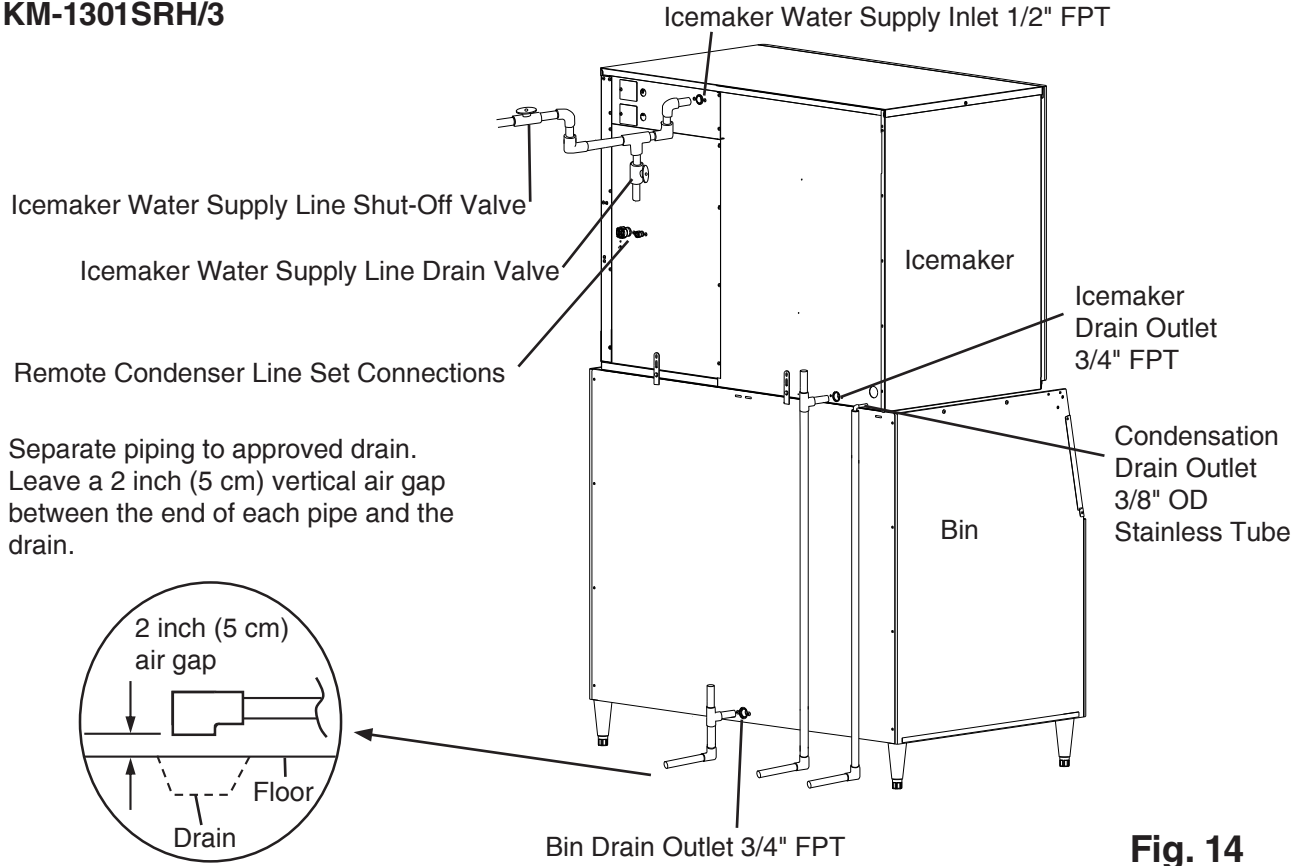

Fig. 14

**KM-1301SWH/3
Connection To A Potable
Water Supply**

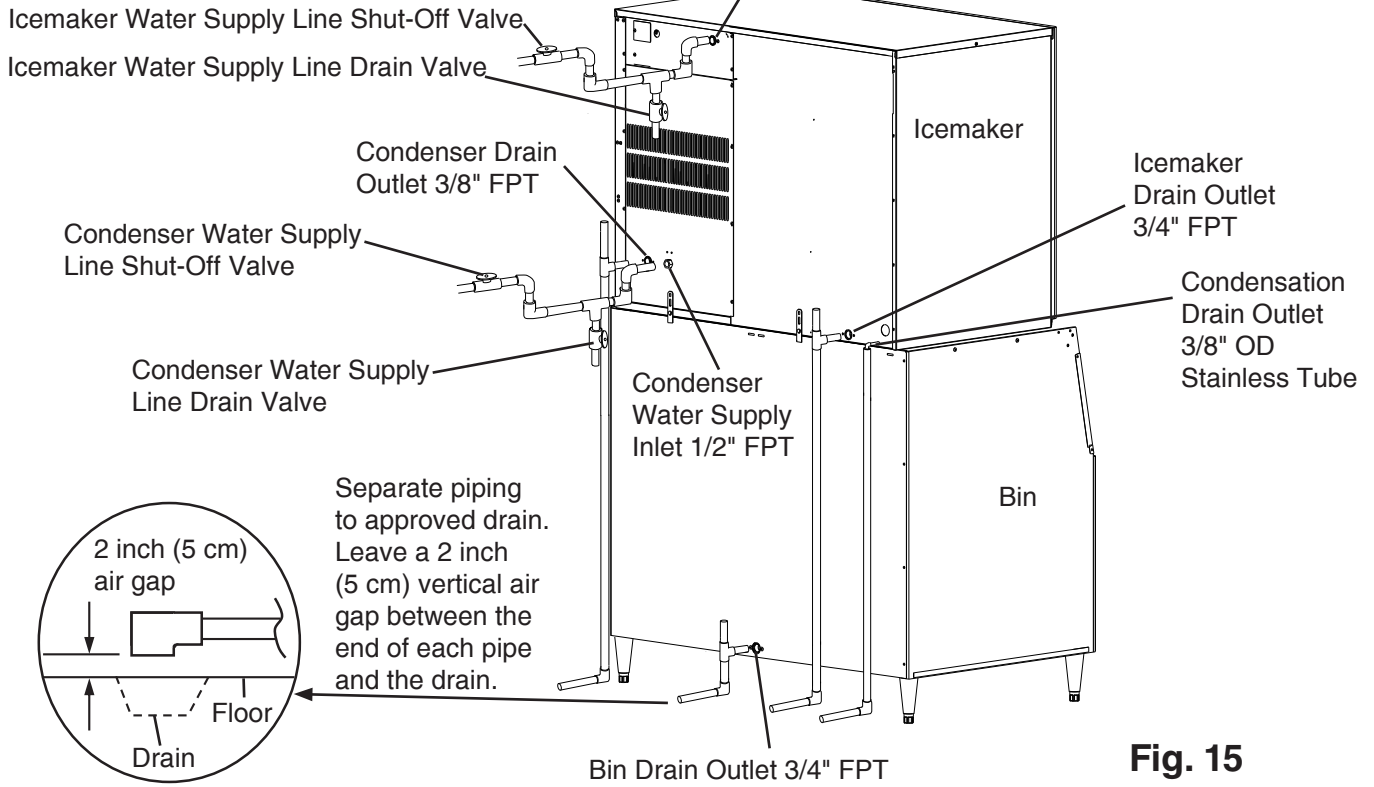

Fig. 15

**KM-1301SWH/3
Connection To A Closed
Loop Water Supply**

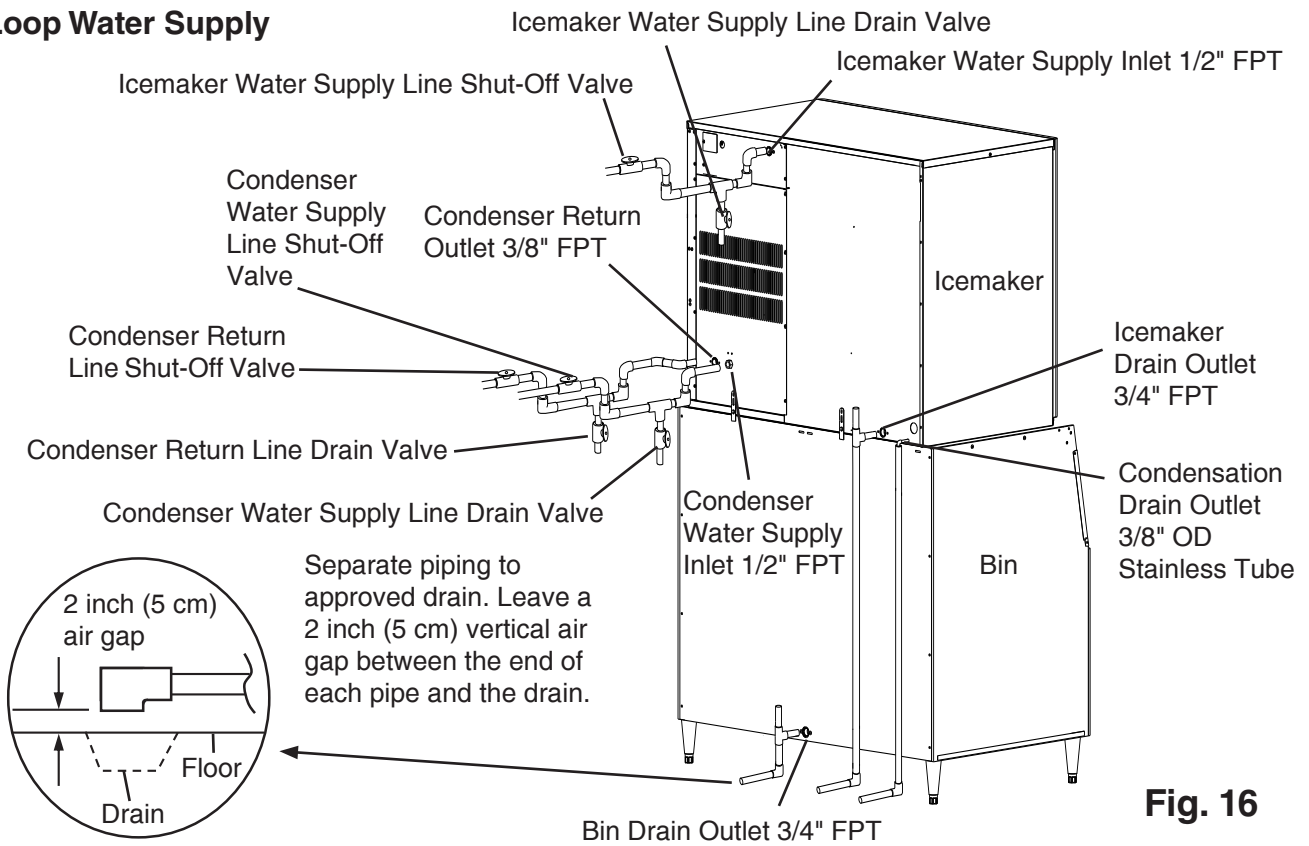

Fig. 16

I. Final Checklist

- 1) Is the icemaker level?
- 2) Is the icemaker in a site where the ambient temperature is within +45°F to +100°F (+7°C to +38°C) and the water temperature within +45°F to +90° (+7°C to +32°C) all year around?
- 3) Is there at least a 6" (15 cm) clearance around the icemaker for maintenance or service?
- 4) Have the shipping carton, tape, and packing material been removed from the icemaker? Are the cube guides in their correct positions? Are the separators between the evaporator banks properly attached to their holding clips?
- 5) Are all components, fasteners, and thumbscrews securely in place?
- 6) Have all electrical, water, and refrigerant (if applicable) connections been made? On remote air-cooled model, are the line sets tightened, secured, and free of kinks?
- 7) Does the electrical installation meet all national, state, and local codes and regulations? Has the power supply voltage been checked or tested against the nameplate rating? Has a proper ground been installed to the icemaker? On remote air-cooled model, has a proper ground also been installed to the remote condenser unit? On three phase models, has the transformer's voltage tap switch been positioned to match incoming voltage?
- 8) On remote air-cooled model, has the electrical power supply been on to the icemaker for a minimum of 4 hours?
- 9) Are the water supply line shut-off valve and drain valve installed? Has the water supply pressure been checked to ensure a minimum of 10 PSIG and a maximum of 113 PSIG?
Note: The icemaker may stop running when the water supply is off, or if the pressure is below 10 PSIG. When the proper water pressure is reached, the icemaker automatically starts running again.
- 10) Are the compressor hold-down bolts snug? Have the refrigerant lines been checked to make sure they do not rub or touch other lines or surfaces? Does the fan blade turn freely?
- 11) Has the end user been given the instruction manual, and instructed on how to operate the icemaker and the importance of the recommended periodic maintenance?
- 12) Has the end user been given the name and telephone number of an authorized service agent?
- 13) Has the warranty card been filled out and forwarded to the factory for warranty registration?

J. Startup

CAUTION

1. All parts are factory-adjusted. Improper adjustments may result in failure.
2. On remote air-cooled model, the icemaker should have power for a minimum of 4 hours prior to startup to prevent compressor damage.
3. If the icemaker is turned off, wait for at least 3 minutes before restarting the icemaker to prevent damage to the compressor.
4. Do not operate the icemaker in the "WASH" position without water in the water tank. This will cause damage to the water pump seal.
5. At startup, confirm that all internal and external connections are free of leaks.

- 1) Open the water supply line shut-off valve.
- 2) Remove the front panel.
- 3) Move the control switch on the control box to the "ICE" position.
- 4) Replace the front panel in its correct position.
- 5) Turn on the power supply, and allow the icemaker to operate for a total of 10 minutes.
- 6) Turn off the power supply, then remove the front panel.
- 7) Remove the insulation panel. Remove the cap located on the front bottom part of the ice dropping hole. Drain the water tank. See Fig. 17.
- 8) Replace the cap, insulation panel, and front panel in their correct positions. Be careful not to cross thread the cap.
- 9) Clean the storage bin liner using a neutral cleaner. Rinse thoroughly after cleaning.
- 10) Turn on the power supply to start the automatic icemaking process.
- 11) When the icemaker is running, hold an ice cube in contact with the bulb. The icemaker should stop within 3 to 10 seconds. Adjustment may be needed, particularly at higher altitude locations.

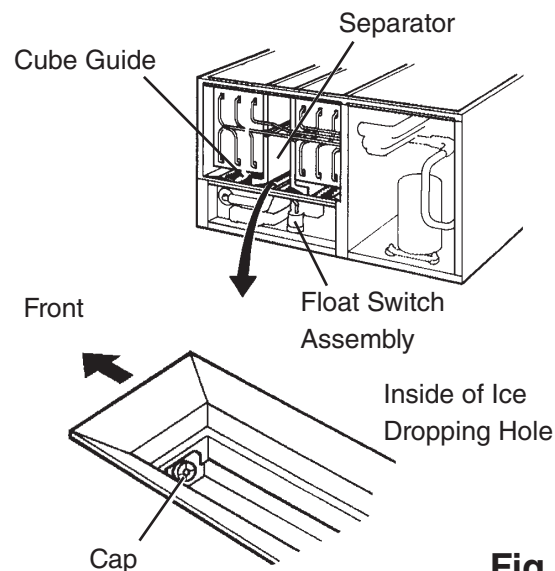

Fig. 17

III. Cleaning and Maintenance

IMPORTANT

Ensure all components, fasteners, and thumbscrews are securely in place after any cleaning or maintenance is done to the equipment.

A. Cleaning and Sanitizing Instructions

Hoshizaki recommends cleaning this icemaker at least once a year. More frequent cleaning, however, may be required in some existing water conditions.

WARNING

1. To prevent injury to individuals and damage to the icemaker, do not use ammonia type cleaners.
2. Always wear liquid-proof gloves to prevent the cleaning and sanitizing solutions from coming into contact with skin.
3. Carefully follow any instructions provided with the bottles of cleaning and sanitizing solution.
4. Never run the icemaker when the water tank is empty.

IMPORTANT

1. The cleaning valve is used to allow solution flow to the inside of the evaporator during the cleaning and sanitizing operation. It should be closed for all icemaking operation. The compressor will not operate unless this valve is completely closed.
2. To open the cleaning valve, the valve handle should be parallel to the valve body. To close the valve, the valve handle should be at a right angle to the valve body.

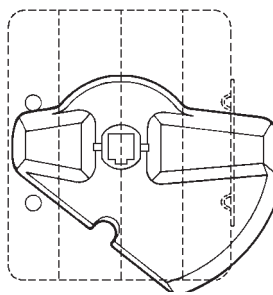

CLOSED POSITION

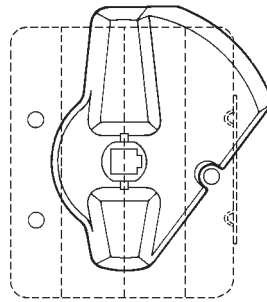

OPEN POSITION

1. Cleaning Procedure

- 1) Dilute 27 fl. oz. (800 ml) of Hoshizaki "Scale Away" with 5 gal. (19 l) of warm water.
- 2) Remove all ice from the evaporator and the storage bin.
Note: To remove cubes on the evaporator, turn off the power supply and turn it on after 3 minutes. The harvest cycle starts and the cubes will be removed from the evaporator.
- 3) Turn off the power supply.
- 4) Remove the front panel, and then remove the insulation panel by first removing the thumbscrew, lifting up the panel slightly and pulling it towards you.
- 5) Remove the cap located on the front bottom part of the ice dropping hole. Drain the water tank. See Fig. 17.
- 6) Replace the cap in its correct position. Be careful not to cross thread it.
- 7) In bad or severe water conditions, clean the float switch assembly as described below. Otherwise, continue to step 8.
 - a. Disconnect the vent tube and the flush tube from the top of the float switch, then remove the float switch assembly from the mounting bracket and remove the rubber boot from the bottom of the assembly.
 - b. Remove the retainer rod from the bottom of the float switch assembly, then remove the float. Be careful not to bend the retainer rod excessively when removing it.
 - c. Wipe down the float switch assembly's housing, shaft, float, and retainer rod with cleaning solution. Clean the inside of the rubber boot and hose with cleaning solution. Rinse the parts thoroughly with clean water.
 - d. Reassemble the float switch assembly and replace it and the rubber boot in their correct positions. Reconnect the vent tube and the flush tube.
- 8) Pour the cleaning solution into the water tank.
- 9) Fully open the cleaning valve on the left side wall of the machine compartment.
- 10) Move the control switch on the control box to the "WASH" position.
- 11) Replace the insulation panel and the front panel in their correct positions.
- 12) Turn on the power supply to start the washing process.
- 13) Turn off the power supply after 30 minutes.
- 14) Remove the front panel and the insulation panel.
- 15) Remove the cap located on the front bottom part of the ice dropping hole. Drain the water tank. Replace the cap and the insulation panel in their correct positions.
- 16) Move the control switch to the "ICE" position.
- 17) Close the cleaning valve.
Note: The icemaker will not operate unless the cleaning valve is completely closed.
- 18) Replace the front panel in its correct position.
- 19) Turn on the power supply to fill the water tank with water.
- 20) Turn off the power supply after 3 minutes.

- 21) Remove the front panel and fully open the cleaning valve.
- 22) Move the control switch to the "WASH" position.
- 23) Replace the front panel in its correct position.
- 24) Turn on the power supply to rinse off the cleaning solution.
- 25) Turn off the power supply after 5 minutes.
- 26) Remove the front panel and the insulation panel.
- 27) Remove the cap located on the front bottom part of the ice dropping hole. Drain the water tank. Replace the cap and the insulation panel in their correct positions.
Note: Do not replace the insulation panel when you proceed to "2. Sanitizing Procedure."
- 28) Repeat steps 16 through 27 three more times to rinse thoroughly.
Note: If you do not sanitize the icemaker, go to step 9 in "2. Sanitizing Procedure."

2. Sanitizing Procedure - Following Cleaning Procedure

- 1) Dilute 2.5 fl. oz. (74 ml or 5 tbs) of a 5.25% sodium hypochlorite solution (chlorine bleach) with 5 gal. (19 l) of warm water.
- 2) Pour the sanitizing solution into the water tank.
- 3) Replace the insulation panel and the front panel in their correct positions.
Note: Make sure that the control switch is in the "WASH" position and the cleaning valve is open.
- 4) Turn on the power supply to start the sanitizing process.
- 5) Turn off the power supply after 15 minutes.
- 6) Remove the front panel and the insulation panel.
- 7) Remove the cap located on the front bottom part of the ice dropping hole. Drain the water tank. Replace the cap and the insulation panel in their correct positions.
- 8) Repeat steps 16 through 27 in "1. Cleaning Procedure" two times to rinse thoroughly.
- 9) Close the cleaning valve.
- 10) Move the control switch to the "ICE" position.
- 11) Replace the front panel in its correct position.
- 12) Clean the storage bin using a neutral cleaner. Rinse thoroughly after cleaning.
- 13) Turn on the power supply to start the automatic icemaking process.

B. Maintenance Instructions

IMPORTANT

This icemaker must be maintained individually, referring to the instruction manual and labels provided with the icemaker.

1. Stainless Steel Exterior

To prevent corrosion, wipe the exterior occasionally with a clean, soft cloth. Use a damp cloth containing a neutral cleaner to wipe off oil or dirt build up.

2. Storage Bin and Scoop

- Wash your hands before removing ice. Use the plastic scoop provided (bin accessory).
- The storage bin is for ice use only. Do not store anything else in the storage bin.
- Clean the scoop and storage bin liner using a neutral cleaner. Rinse thoroughly after cleaning.

3. Air Filters (air-cooled model only)

Plastic mesh air filters remove dirt and dust from the air, and keep the condenser from getting clogged. As the filters get clogged, the icemaker's performance will be reduced. Check the filters at least twice a month. When clogged, use warm water and a neutral cleaner to wash the filters.

4. Condenser (air-cooled and remote air-cooled models only)

Check the condenser once a year, and clean the coil if required by using a brush or vacuum cleaner. More frequent cleaning may be required depending on location.

C. Preparing the Icemaker for Long Storage

IMPORTANT

When shutting off the icemaker for an extended time, drain out all water from the water tank and remove the ice from the storage bin. The storage bin should be cleaned and dried. Drain the icemaker to prevent damage to the water supply line at sub-freezing temperatures, using air or carbon dioxide. Shut off the icemaker until the proper ambient temperature is resumed.

When the icemaker is not used for two or three days, it is sufficient to only move the control switch to the "OFF" position, unless the icemaker will be at sub-freezing temperatures.

1. On water-cooled model only, first remove the water from the water-cooled condenser:

- 1) Turn off the power supply and remove the front panel and right side panel.
- 2) Close the condenser water supply line shut-off valve. If connected to a closed loop water supply, also close the condenser return outlet shut-off valve. See Fig. 14 for a condenser connected to a potable water supply and Fig.15 for a condenser connected to a closed loop water supply.
- 3) Open the condenser water supply line drain valve. If connected to a closed loop water supply, also open the condenser return outlet drain valve.

- 4) Attach a compressed air or carbon dioxide supply to the condenser water supply line drain valve.
- 5) Open the water regulating valve by using a screwdriver to pry up on the spring retainer underneath the spring. While holding the valve open, blow out the condenser using the compressed air or carbon dioxide supply until water stops coming out.
- 6) Close the drain valve(s) and replace the right side panel in its correct position.

2. Remove the water from the icemaker water supply line:

- 1) If you have not already done so, turn off the power supply and remove the front panel.
- 2) Close the icemaker water supply line shut-off valve and open the icemaker water supply line drain valve.
- 3) Allow the line to drain by gravity.
- 4) Attach a compressed air or carbon dioxide supply to the icemaker water supply line drain valve.
- 5) Make sure at least 3 minutes have elapsed since you turned off the power supply. Make sure the control switch is in the "ICE" position. Replace the front panel in its correct position and turn on the power supply.
- 6) Blow the icemaker water supply line out using the compressed air or carbon dioxide supply.
- 7) Close the icemaker water supply line drain valve.

3. Drain the water tank:

- 1) Turn off the power supply and remove the front panel. Move the control switch to the "OFF" position.
- 2) Remove the insulation panel. Remove the cap located on the front bottom part of the ice dropping hole. Drain the water tank. See Fig. 17.
- 3) Replace the cap and the insulation panel in their correct positions. Be careful not to cross thread the cap.
- 4) Remove all ice from the storage bin. Clean the storage bin using a neutral cleaner. Rinse thoroughly after cleaning.
- 5) Replace the front panel in its correct position.

HOSHIZAKI AMERICA, INC.

618 Hwy. 74 S., Peachtree City, GA 30269 USA | TEL (770) 487-2331 | FAX (770) 487-3360 | www.hoshizaki.com | 1A2910-010