



# HOSHIZAKI

---

## Parts List

Modular Crescent Cuber

Model  
KM-201BWH



[hoshizakiamerica.com](http://hoshizakiamerica.com)

Number: F042-3251  
Issued: 7-2016

## Auxiliary Codes

<b>KM-201BWH</b>	U-1	September 2009
	V-1	April 2010
	V-2	August 2010

### Auxiliary Code Breakdown

The auxiliary code is the first two characters in the serial number. The first character indicates the year. Years progress or regress in alphabetical order. The series runs from "A" through "V" and the letters "I" and "O" are skipped. The second character indicates significant part changes within a year. Base is "0" and this number advances for each change. In cases where there is a letter in parentheses, this designates the month. This is the last character in the serial number. The series runs from "(A)" through "(M)" and the letter "(I)" is skipped. This designation is only included when identifying a parts change within an auxiliary code.

### Note About Ordering Parts

Most assemblies cannot be ordered as complete units; parts in the assemblies generally must be ordered separately.

**MARKS LOCATED UNDER THE AUXILIARY CODE**

- = Part deleted.
- x = Part deleted and replaced by "o" part.
- o = New part in place of "x" part.

**FASTENER PART NUMBER**

**SCREWS**

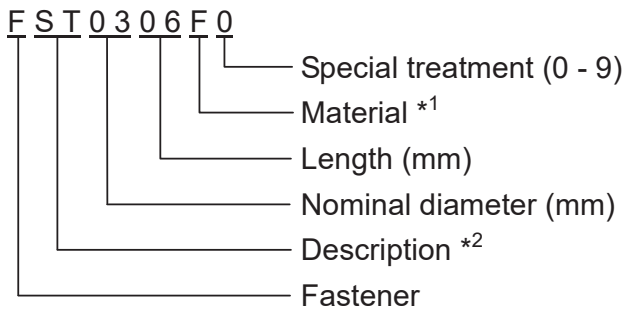

\*1 Material

- F: Steel
- S: Austenitic stainless steel
- M: Martensitic stainless steel
- B: Copper alloy
- P: Polycarbonate
- N: Polyamide
- V: PVC
- A: ABS
- X: Polyacetal
- L: Aluminum

**NUTS & WASHERS**

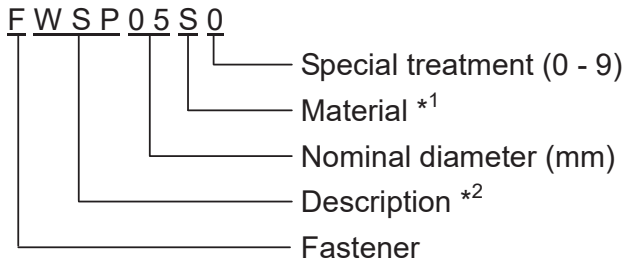

\*2 Description

- First letter
- S: Machine screw
  - T: Tapping screw
  - M: Wood screw
  - B: Bolt
  - W: Washer
  - N: Nut

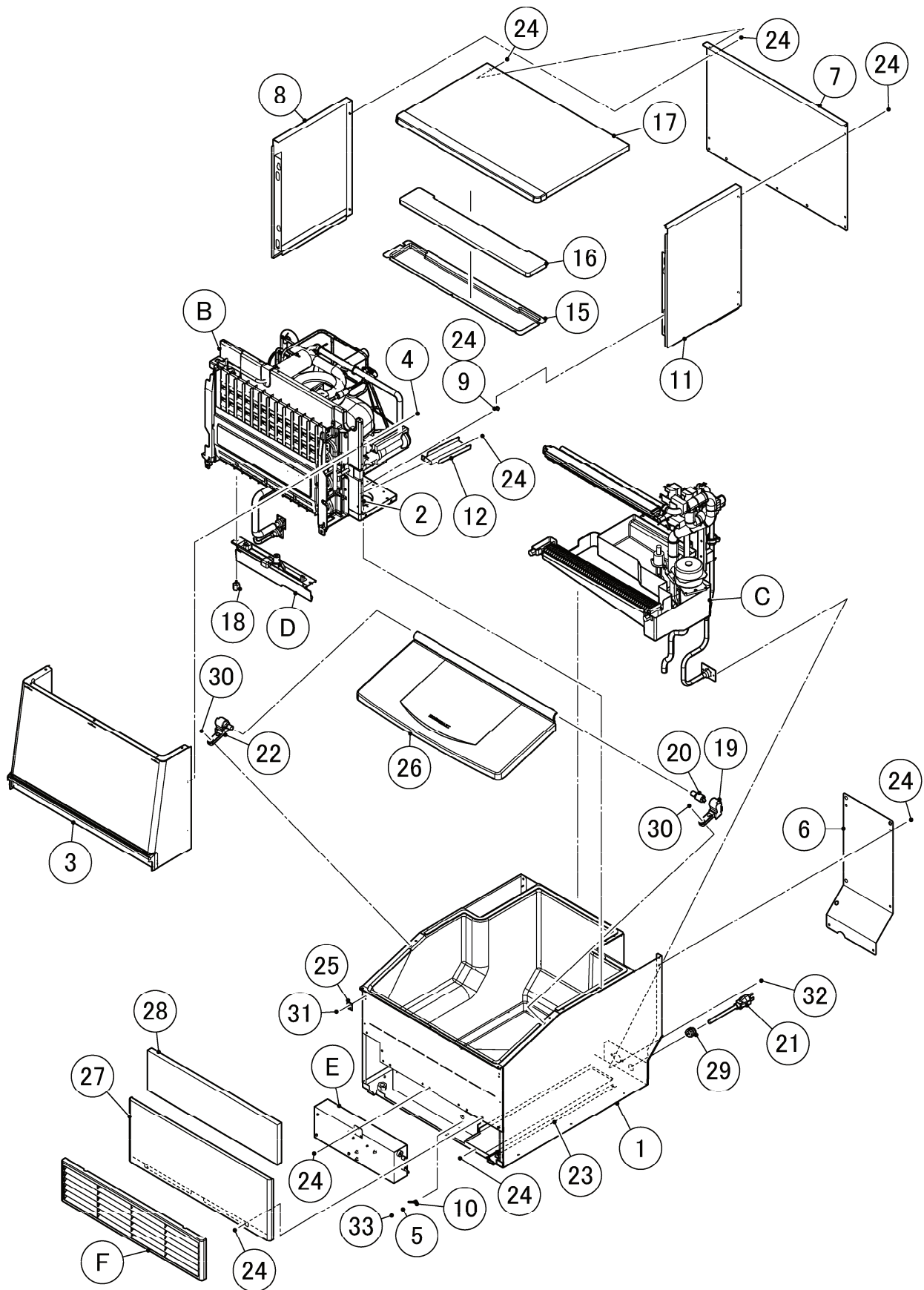

HA

MODEL: <b>KM-201BWH</b>		TITLE: <b>A. ICE CUBER ASSY</b>					
INDEX NO.	DESCRIPTION	MATERIAL OR MODEL NUMBER	PART NUMBER	REQ'D NUMBER			
				U-1 V-0	V-1	V-2	
B	REFRIGERATION CIRCUIT		119776A01	1	1	1	
C	WATER CIRCUIT - 24		119152A01	1	-	-	
			120502A01		1	1	
D	MECHANICAL BIN SWITCH		370982A01	1	1	1	
E	CONTROL BOX ASSY		371208A02	1	1	1	
F	LOUVER ASSY - 24		371425A02	1	1	1	
G	LABEL LOCATION		256080A04	1	1	1	
H	ACCESSORIES		A01679-01	1	1	1	
1	BIN ASSY - 24		118999G04	1	1	1	
2	TRUSS HEAD SCREW	SUS 4x35	FST0430S0	4	4	4	
3	FRONT COVER - 24		255322G02	1	1	1	
4	TRUSS HEAD SCREW	SUS 4x20	FST0420S0	4	4	4	
5	SPRING WASHER	4	FWSP04S0	1	1	1	
6	REAR COVER		371199M01	1	1	1	
7	REAR PANEL (UP)		371248M02	1	1	1	
8	SIDE PANEL (L,UP)		371013G02	1	1	1	
9	TAPER COLLAR		4H0171-01	4	4	4	
10	WIRE HARNESS		255562Z01	1	1	1	
11	SIDE PANEL (R,UP)		371015G03	1	1	1	
12	BARRIER		474515M01	1	1	1	
15	TOP COVER - 24		255268P01	1	1	1	
16	INSULATION - TOP (24)		472571P01	1	1	1	
17	TOP PANEL - 24		371178G02	1	1	1	
18	THUMB SCREW		415949G12	2	2	2	
19	HINGE MOUNT(R)		370969P01	1	1	1	
20	HINGE	FYN-P1-R103	P01080-01	1	1	1	
21	POWER SUPPLY CORD	KR-301+SJT 16AWGX3C	P00004-01	1	1	1	
22	HINGE MOUNT(L)		370970P01	1	1	1	
23	WIRE COVER		372564M01	1	1	1	
24	TRUSS HEAD SCREW	4x8	FST0408F0	25	25	25	
25	CLAMP		472587M01	2	2	2	
26	DOOR ASSY - 24		371214G01	1	1	1	

HA

MODEL: <b>KM-201BWH</b> TITLE: <b>A. ICE CUBER ASSY</b>							
INDEX NO.	DESCRIPTION	MATERIAL OR MODEL NUMBER	PART NUMBER	REQ'D NUMBER			
				U-1 V-0	V-1	V-2	
27	FRONT PANEL (LO)		255033M03	1	1	1	
28	INSULATION (F) - 24		472743P01	1	1	1	
29	BUSHING	SR-7K-2	420472-02	1	1	1	
30	PAN HEAD SCREW (S)	SUS 5x16 KP-707Y, RVV 3x1.0	FSS0516S0	4	4	4	
31	TRUSS HEAD TAPPING SCREW (TYPE B)	4x8	FT20408F0	2	2	2	
32	T2 SCREW	SUS 4x12	FT20412M0	6	6	6	
33	TRUSS HEAD SCREW	4x8	FST0408S0	1	1	1	

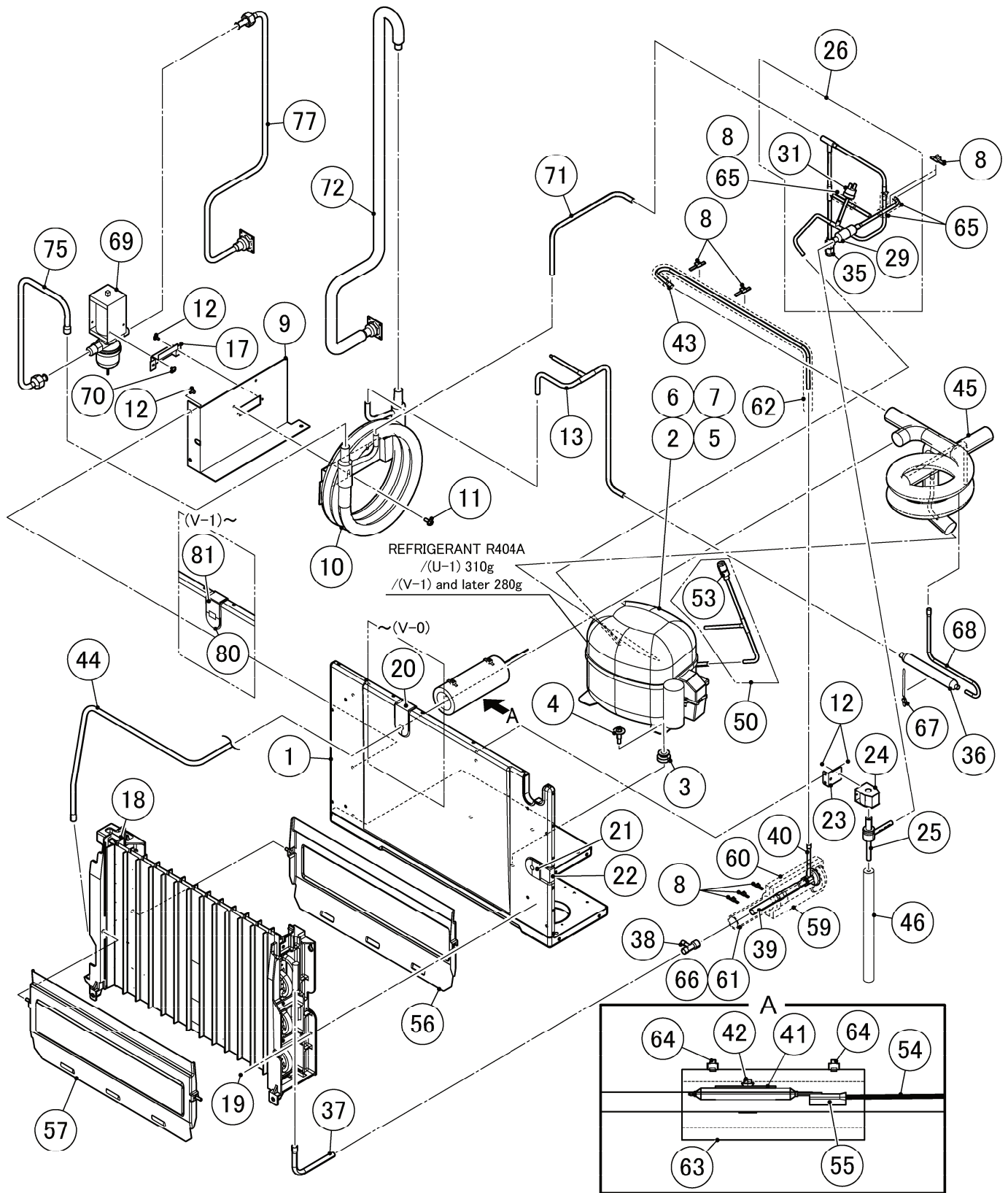

HA

MODEL: <b>KM-201BWH</b>		TITLE: <b>B. REFRIGERATION CIRCUIT</b>					
INDEX NO.	DESCRIPTION	MATERIAL OR MODEL NUMBER	PART NUMBER	REQ'D NUMBER			
				U-1 V-0	V-1	V-2	
1	BASE ASSY 24		372010G01	1	-	-	
			374019G01		1	1	
2	COMPRESSOR	NF7CLX 115V 60Hz	P01130-01	1	1	1	
3	RUBBER GROMMET	118-3661	4A1452-01	4	4	4	
4	BOLT	M6	468180-01	4	4	4	
5	STARTER		4A4232-01	1	1	1	
6	COVER		4A2141-01	1	1	1	
7	STARTING CAPACITOR		4A2134-04	1	1	1	
8	TIE	CV-150	7920-0003	12	12	12	
9	BRACKET - COND		373089M01	1	1	1	
10	CONDENSER - WATER COOLED		P01539-01	1	1	1	
11	FLANGE BOLT	5x12	FTQ0512F0	2	2	2	
12	TRUSS HEAD SCREW	4X8	FST0408F0	9	9	9	
13	COPPER TUBE (D)		373091G01	1	1	1	
17	BRACKET-WR		474195M01	1	1	1	
18	EVAPORATOR ASSY		371399G01	1	-	-	
			374022G01		1	1	
19	TRUSS HEAD SCREW	SUS 4X12	FST0412S0	4	4	4	
20	GROMMET (A)		472435R01	1	-	-	
21	GROMMET (C1)		472437R01	1	1	1	
22	GROMMET (C2)		472560R01	1	1	1	
23	BRACKET - HOT GAS		472590M01	1	1	1	
24	COIL - VALVE	AMS-C12HDU-3	4A3277-01	1	1	1	
25	VALVE BODY	ATS-B7SHDU-2	4A3978-01	1	1	1	
26	COPPER TUBE (A) - H		371578G02	1	1	1	
29	STRAINER	COPPER TUBE (A) - H 371578G02	P00812-01	1	1	1	
31	PRESSURE SWITCH	COPPER TUBE (A) - H 371578G02 ACB-1UB44	463180-05	1	1	1	
35	ACCESS VALVE	COPPER TUBE (A) - H 371578G02 TCJ-2F20NHDU-1	457729-01	1	1	1	



HA

MODEL: <b>KM-201BWH</b>		TITLE: <b>B. REFRIGERATION CIRCUIT</b>					
INDEX NO.	DESCRIPTION	MATERIAL OR MODEL NUMBER	PART NUMBER	REQ'D NUMBER			
				U-1 V-0	V-1	V-2	
36	DRIER		P00026-01	1	1	1	
37	COPPER TUBE (B) - L		472597M01	1	-	-	
			474848M01		1	1	
38	TEE	111R-642	436000-08	1	1	1	
39	COPPER TUBE (A) - L		472596M01	1	1	1	
40	EXP. VALVE		P01129-01	1	1	1	
41	HOLDER - EXPV		451267-01	1	1	1	
42	CLAMP		443461-01	1	1	1	
43	COPPER TUBE (C) - H		371398M01	1	1	1	
44	COPPER TUBE (C) - L		371397M01	1	-	-	
			374258M01		1	1	
45	HEAT EXCHANGER		255645G01	1	1	1	
46	COPPER TUBE - HOT GAS		373099G01	1	1	1	
50	COPPER TUBE - ACCESS VALVE		472801G01	1	1	1	
53	ACCESS VALVE	COPPER TUBE - ACCESS VALVE 472801G01 TCJ-2F20NHDU-1	457729-01	1	1	1	
54	THERMISTOR		P00027-01	1	1	1	
55	HOLDER - THERMISTOR		436455-01	1	1	1	
56	SEPARATOR		370971G01	1	1	1	
57	SEPARATOR		370971G02	1	1	1	
59	COVER (A) - EXP. VALVE		324313-01	1	1	1	
60	COVER (B) - EXP. VALVE		324313-02	1	1	1	
61	INSULATION TUBE	7762-1323 L=140	H71323140	1	1	1	
62	INSULATION TUBE	7762-0717 L=600	H70717600	1	1	1	
63	INSULATION TUBE	7762-3858 L=150	H73858150	1	1	1	
64	TIE	CV-200	7920-0010	2	2	2	
65	INSULATION TUBE	7762-1020 L=50	H71020050	4	4	4	
66	INSULATION TUBE	7762-2030 L=100	H72030100	1	1	1	
67	PUSH MOUNT TIE	T30RSF	436156-01	1	1	1	
68	COPPER TUBE (B) - H		472795M01	1	1	1	
69	WATER REGULATOR		P04025-01	1	1	1	
70	TRUSS HEAD SCREW	4x6	FST0406F0	2	2	2	
71	COPPER TUBE (A5) - H		474196M01	1	1	1	

HA

MODEL: <b>KM-201BWH</b>		TITLE: <b>B. REFRIGERATION CIRCUIT</b>					
INDEX NO.	DESCRIPTION	MATERIAL OR MODEL NUMBER	PART NUMBER	REQ'D NUMBER			
				U-1 V-0	V-1	V-2	
72	COPPER TUBE (A) - WC		373092G01	1	1	1	
75	COPPER TUBE (B) - WC		474197G01	1	1	1	
77	COPPER TUBE (C) - WC		373093G01	1	1	1	
80	GROMMET (A1)		475110R01		1	1	
81	GROMMET (A2)		475111R01		1	1	

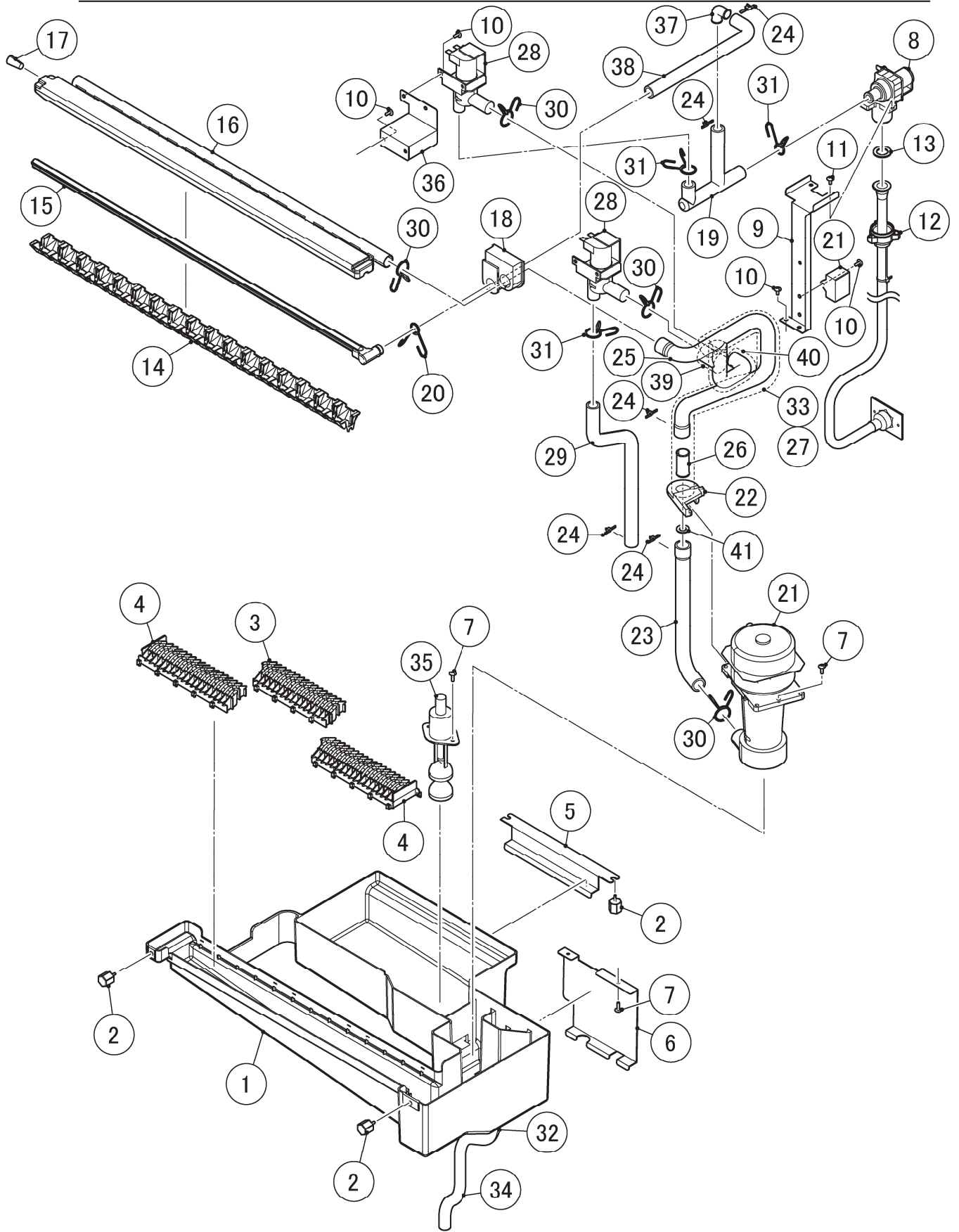

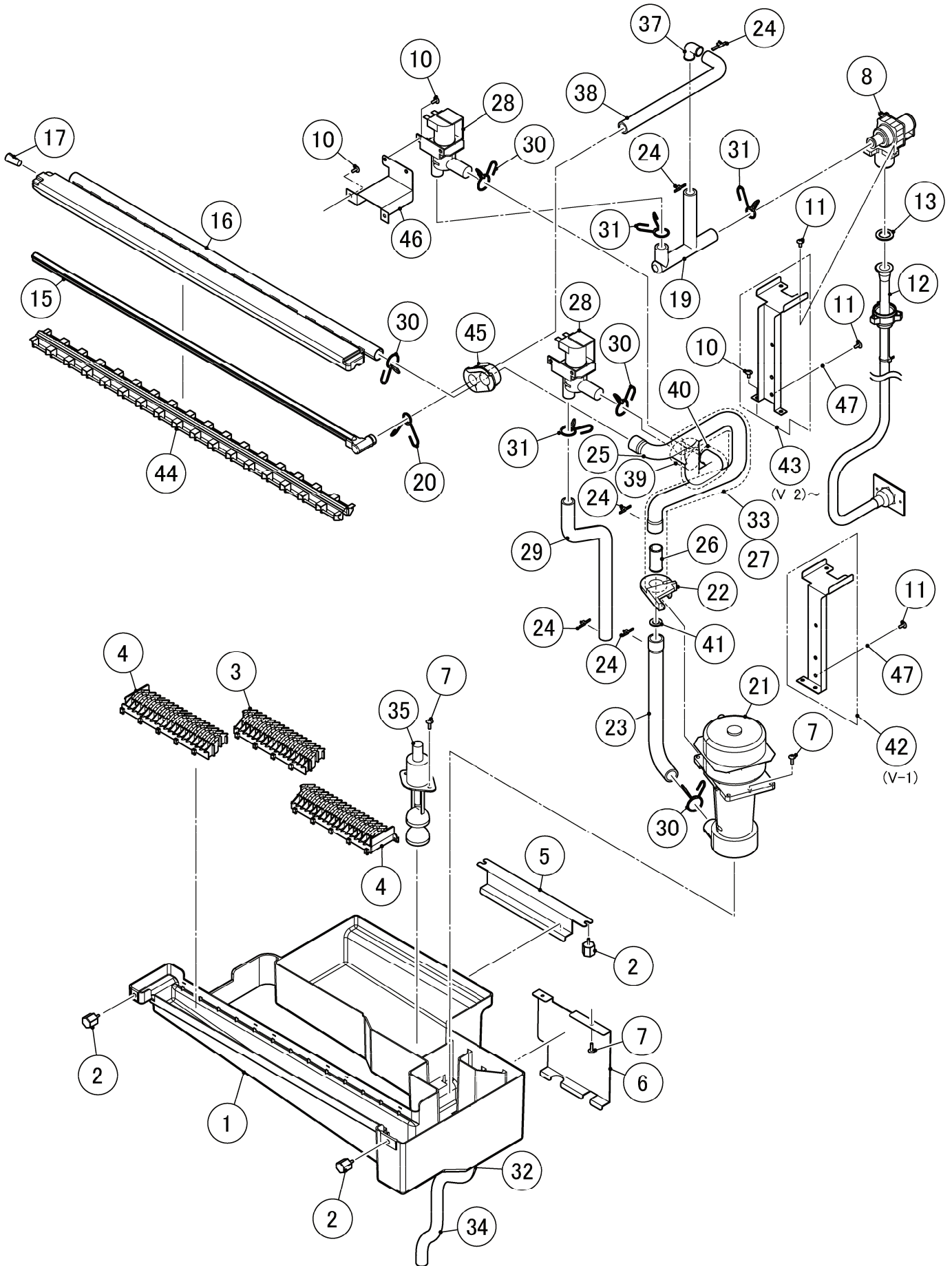

HA

MODEL: <b>KM-201BWH</b>		TITLE: <b>C. WATER CIRCUIT</b>					
INDEX NO.	DESCRIPTION	MATERIAL OR MODEL NUMBER	PART NUMBER	REQ'D NUMBER			
				U-1 V-0	V-1	V-2	
1	TANK - 24		118944P01	1	1	1	
2	THUMBSCREW		415949G12	4	4	4	
3	CUBE GUIDE (B)		2A3363-01	1	1	1	
4	CUBE GUIDE (A)		2A3362-01	2	-	-	
			258598P01		2	2	
5	HOOK (B) - TANK		371007M01	1	1	1	
6	HOOK (D) - TANK		371204M01	1	1	1	
7	TRUSS HEAD SCREW	SUS 4x12	FST0412S0	6	6	6	
8	WATER VALVE	2L/min	3U0150-01	1	1	1	
9	BRACKET (A) - WATER VALVE		372006M01	1	-	-	
10	TRUSS HEAD SCREW	4x8	FST0408F0	9	9	9	
11	TRUSS HEAD SCREW	SUS 4x8	FST0408S0	2	3	3	
12	WATER SUPPLY PIPE		371230G01	1	-	-	
			373857G01		1	1	
13	RUBBER GASKET		413854-03	1	1	1	
14	SPRAY GUIDE		118939P02	1	-	-	
15	WATER SUPPLY TUBE		250743-03	1	1	1	
16	SPRAY TUBE - 24		255329P01	1	1	1	
17	PLUG		4A0176-01	1	1	1	
18	GROMMET (B)		472436R01	1	-	-	
19	WATER SUPPLY PIPE (A)		472438R01	1	1	1	
20	HOSE CLAMP ※Use either of the right	13.5mm SUS	427443-07	1	1	1	
			P02909-07	1	1	1	
21	PUMP MOTOR	PV-0511BHZ1	P00468-01	1	1	1	
22	COVER - PUMP MOTOR		371173R01	1	1	1	
23	WATER SUPPLY PIPE (E)		472558R01	1	-	-	
			474711R01		1	1	
24	TIE	CV-100	7920-0002	5	5	5	
25	WATER SUPPLY PIPE (F)		255236R01	1	1	1	
26	SOCKET		472564P01	1	1	1	
27	TIE	CV-150	7920-0003	15	15	15	
28	SOLENOID VALVE	FDC-90-02-115	P00018-02	2	2	2	

HA

MODEL: <b>KM-201BWH</b>		TITLE: <b>C. WATER CIRCUIT</b>					
INDEX NO.	DESCRIPTION	MATERIAL OR MODEL NUMBER	PART NUMBER	REQ'D NUMBER			
				U-1 V-0	V-1	V-2	
29	DRAIN PIPE		472441R01	1	-	-	
			472441R02		1	1	
30	HOSE CLAMP ※Use either of the right	20mm SUS	427443-06	4	4	4	
			P02909-06	4	4	4	
31	HOSE CLAMP ※Use either of the right	18mm SUS	427443-05	3	3	3	
			P02909-05	3	3	3	
32	SILICONE HOSE	φ14×φ18×L30	H11418030	1	1	1	
33	INSULATION TUBE	7762-2030 L=510	H72030510	1	-	-	
			H72030480		1	1	
34	DRAIN PIPE (B)		472442P01	1	1	1	
35	FLOAT SWITCH	OLV-29Z-2P2	P00816-01	1	1	1	
36	BRACKET(B) - WATER VALVE		472467M01	1	1	-	
37	ELBOW		470303-01	1	1	1	
38	WATER SUPPLY PIPE (B)		472439R01	1	1	1	
39	INSULATION TUBE	7762-2030 L=30	H72030030	1	1	1	
40	INSULATION TUBE	7762-2030 L=200	H72030200	1	1	1	
41	ORIFICE		4Y4194P01	1	1	1	
42	BRACKET (A) - WATER VALVE		373853M01		1	-	
43	BRACKET (A) - WATER VALVE		374254M01			1	
44	SPRAY GUIDE		258313P05		1	1	
45	GROMMET		474786R01		1	1	
46	BRACKET (B) - WATER VALVE		475117M01		-	1	
47	SPRING WASHER		FWSP04S0	1	1	1	

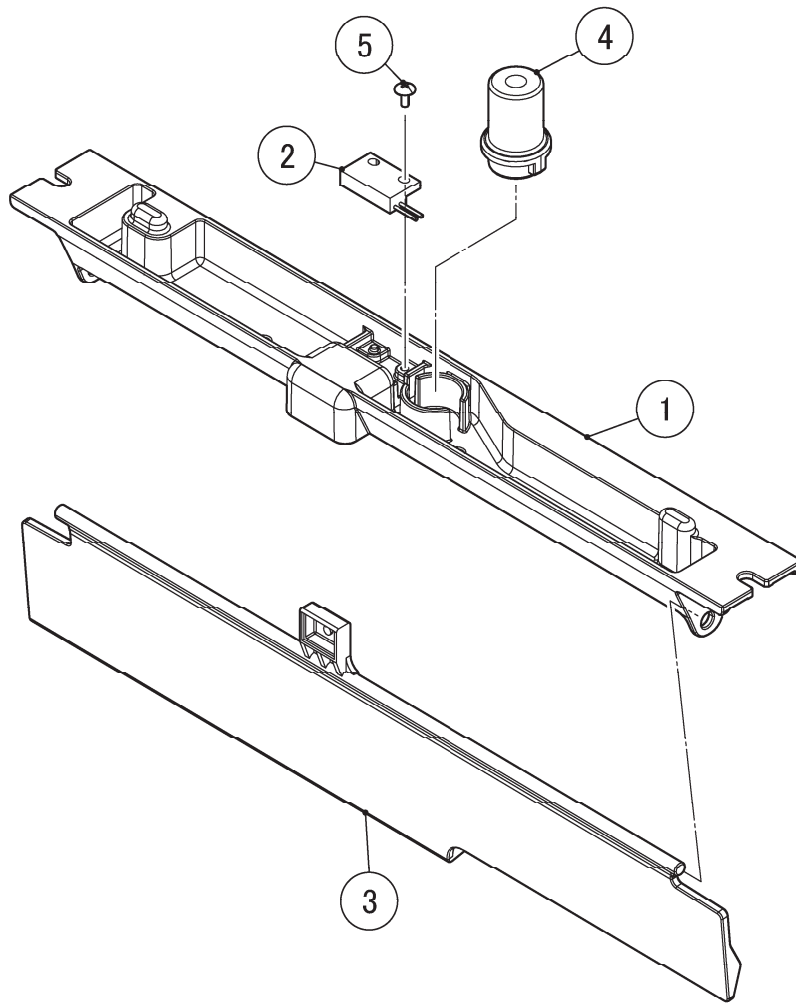

HA

<b>MODEL: KM-201BWH</b>		<b>TITLE: D. MECHANICAL BIN SWITCH</b>					
-------------------------	--	--	--	--	--	--	--

INDEX NO.	DESCRIPTION	MATERIAL OR MODEL NUMBER	PART NUMBER	REQ'D NUMBER			
				U-1 V-0	V-1	V-2	
1	BASE ACTUATOR		118845P01	1	1	1	
2	REED SWITCH		431788-02	1	1	1	
3	ACTUATOR		370981G01	1	1	1	
4	GROMMET (E)		472446R01	1	1	1	
5	TRUSS HEAD SCREW	SUS 3X8	FT20308M0	1	1	1	



