



# HOSHIZAKI

## Service Manual

Modular Crescent Cuber

Models

KM-520MAJ-E

KM-660MAJ-E



[hoshizakiamerica.com](http://hoshizakiamerica.com)

Number: 73232  
Issued: 10-19-2018  
Revised: 12-7-2023

**⚠ WARNING**

Only qualified service technicians should install and service the appliance. To obtain the name and phone number of your local Hoshizaki Certified Service Representative, visit [www.hoshizaki-europe.com](http://www.hoshizaki-europe.com). No service should be undertaken until the technician has thoroughly read this Service Manual. Failure to service and maintain the appliance in accordance with this manual will adversely affect safety, performance, component life, and warranty coverage and may result in costly water damage. Proper installation is the responsibility of the installer. Product failure or property damage due to improper installation is not covered under warranty.

Hoshizaki provides this manual primarily to assist qualified service technicians in the service and maintenance of the appliance. Should the reader have any questions or concerns which have not been satisfactorily addressed, please call the appropriate Hoshizaki Service Office:

UK/Ireland - Hoshizaki UK  
TEL : +44 (0)845 456 0585  
FAX: +44 (0)132 283 8331

Holland - Hoshizaki Europe  
TEL : +31 (0)20 6918499  
FAX: +31 (0)20 6918768

Belgium/Luxemburg - Hoshizaki Belgium  
TEL : +32 (0)2 7123030  
FAX: +32 (0)2 7123031

Germany/Switzerland/Austria - Hoshizaki Deutschland  
TEL : +49 (0)2154 92810  
FAX: +49 (0)2154 928128

France - Hoshizaki France  
TEL : +33 (0)1 48639380  
FAX: +33 (0)1 48639388

Other countries - Hoshizaki Europe  
TEL: +31 (0)20 6918499  
FAX: +31 (0)20 6918768

Web Site: [www.hoshizaki-europe.com](http://www.hoshizaki-europe.com)

**NOTE:** To expedite assistance, all correspondence/communication **MUST** include the following information:

- Model Number \_\_\_\_\_
- Serial Number \_\_\_\_\_
- Complete and detailed explanation of the problem.

## **IMPORTANT**

This manual should be read carefully before the appliance is serviced. Read the warnings and guidelines contained in this manual carefully as they provide essential information for the continued safe use, service, and maintenance of the appliance. Retain this manual for any further reference that may be necessary.

## **CONTENTS**

|  |    |
|--|----|
| Important Safety Information .....   | 5  |
| I. Construction and Water/Refrigeration Circuit Diagram .....  | 7  |
| A. Construction .....  | 7  |
| B. Water/Refrigeration Circuit Diagram .....   | 8  |
| II. Sequence of Operation and Service Diagnosis .....  | 9  |
| A. Sequence of Operation Flow Chart .....  | 9  |
| 1. Operation Flow Chart .....  | 9  |
| 2. Shutdown Flow Chart .....   | 10 |
| B. Service Diagnosis .....   | 11 |
| 1. K Control Board (2A8242-02) with Ultrasonic Bin Control Used in conjunction with Ultrasonic Bin Control Board (4A6838-01) ..... | 11 |
| 2. K+ Control Board (2A9678-01) with Ultrasonic Bin Control .....  | 17 |
| C. Control Board Check .....   | 24 |
| D. Bin Control Check and Adjustment .....  | 26 |
| E. Float Switch Check and Cleaning .....   | 30 |
| F. Thermistor Check .....  | 32 |
| G. Control Switch .....  | 32 |
| H. Mode Switch .....   | 32 |
| I. Diagnostic Tables .....   | 33 |
| J. Freeze-Up Check List .....  | 37 |
| III. Controls and Adjustments .....  | 38 |
| A. Control Board Layout .....  | 39 |
| 1. K Control Board (2A8242-02) .....   | 39 |
| 2. K+ Control Board (2A9678-01) .....  | 40 |
| B. LED Lights and Audible Alarm Safeties .....   | 41 |
| 1. K Control Board (2A8242-02) .....   | 41 |
| 2. K+ Control Board (2A9678-01) .....  | 42 |
| C. Settings and Adjustments .....  | 43 |
| 1. Default Dip Switch Settings .....   | 43 |
| 2. Harvest Time (S4 dip switch 1 & 2) .....  | 44 |
| 3. Pump-Out Time/Harvest Time During Pump-Out (S4 dip switch 3 & 4) .....  | 44 |
| 4. Pump-Out Frequency Control (S4 dip switch 5) .....  | 45 |
| 5. Harvest Pump Time (Harvest Assist Duration) (S4 dip switch 6) .....   | 45 |
| 6. Harvest Pump Time (Harvest Assist) (S4 dip switch 7) .....  | 46 |
| 7. Factory Use (S4 dip switch 8) .....   | 46 |
| 8. Freeze Timer (S4 dip switch 9 & 10) .....   | 46 |
| 9. Pump-Out Pump Motor Direction (S5 dip switch 1) .....   | 47 |
| 10. Refill Counter (S5 dip switch 2 and 3) .....   | 47 |
| 11. Minimum Harvest Time (S5 dip switch 4) .....   | 47 |
| 12. Anti-Slush (S5 dip switch 5) .....   | 48 |

|  |    |
|--|----|
| IV. Refrigeration Circuit and Component Service Information..... | 49 |
| A. Refrigeration Circuit Service Information .....               | 49 |
| B. Component Service Information.....                            | 52 |
| V. Maintenance .....   | 53 |
| VI. Preparing the Appliance for Periods of Non-Use .....         | 54 |
| VII. Disposal.....   | 55 |
| VIII. Technical Information.....                                 | 56 |
| A. Specification and Performance Data Sheets.....                | 56 |
| 1. KM-520MAJ-E.....  | 56 |
| 2. KM-660MAJ-E .....   | 57 |
| B. Wiring Diagrams .....   | 58 |
| 1. K Control Board (2A8242-02).....                              | 58 |
| 2. K+ Control Board (2A9678-01) .....                            | 59 |

---

## Important Safety Information

Throughout this manual, notices appear to bring your attention to situations which could result in death, serious injury, damage to the appliance, or damage to property.

**⚠ WARNING** Indicates a hazardous situation which could result in death or serious injury.

**NOTICE** Indicates a situation which could result in damage to the appliance or property.

**IMPORTANT** Indicates important information about the use and care of the appliance.

### **⚠ WARNING**

The appliance should be destined only to the use for which it has been expressly conceived. Any other use should be considered improper and therefore dangerous. The manufacturer cannot be held responsible for injury or damage resulting from improper, incorrect, and unreasonable use. Failure to service and maintain the appliance in accordance with this manual will adversely affect safety, performance, component life, and warranty coverage and may result in costly water damage.

**To reduce the risk of death, electric shock, serious injury, or fire, follow basic precautions including the following:**

- Only qualified service technicians should install and service this appliance.
- The appliance must be installed in accordance with applicable national, state, and local codes and regulations.
- Electrical connection must be hard-wired and must meet national, state, and local electrical code requirements. Failure to meet these code requirements could result in death, electric shock, serious injury, fire, or severe damage to equipment.
- The icemaker requires an independent power supply of proper capacity. See the nameplate for electrical specifications. Failure to use an independent power supply of proper capacity can result in a tripped breaker, blown fuses, damage to existing wiring, or component failure. This could lead to heat generation or fire.
- **THE ICEMAKER MUST BE GROUNDED.** Failure to properly ground the icemaker could result in death or serious injury.
- Move the control switch to the "OFF" position and turn off the power supply before servicing. Lockout/Tagout to prevent the power supply from being turned back on inadvertently.
- To reduce the risk of electric shock, do not touch the control switch with damp hands.
- Do not make any alterations to the unit. Alterations could result in electric shock, injury, fire, or damage to the unit.
- The appliance is not intended for use by persons (including children) with reduced physical, sensory, or mental capabilities, or lack of experience and knowledge, unless they have been given supervision or instruction concerning use of the appliance by a person responsible for their safety.

**⚠ WARNING, continued**

- Children should be properly supervised around this appliance.
- Do not climb, stand, or hang on the appliance or allow children or animals to do so. Serious injury could occur or the appliance could be damaged.
- Do not use combustible spray or place volatile or flammable substances near the appliance. They might catch fire.
- Keep the area around the appliance clean. Dirt, dust, or insects in the appliance could cause harm to individuals or damage to the appliance.

***NOTICE***

- Follow the instructions in this manual carefully to reduce the risk of costly water damage.
- In areas where water damage is a concern, install in a contained area with a floor drain.
- Install the appliance in a location that stays above freezing. Normal operating ambient temperature must be within 45°F to 100°F (7°C to 38°C).
- Do not leave the icemaker on during extended periods of non-use, extended absences, or in sub-freezing temperatures. To properly prepare the icemaker for these occasions, follow the instructions in "VI. Preparing the Appliance for Periods of Non-Use."
- Do not place objects on top of the appliance.
- The dispenser unit/ice storage bin is for ice use only. Do not store anything else in the dispenser unit/ice storage bin.

# I. Construction and Water/Refrigeration Circuit Diagram

## A. Construction

### 1. Air-Cooled Models (MAJ-E)

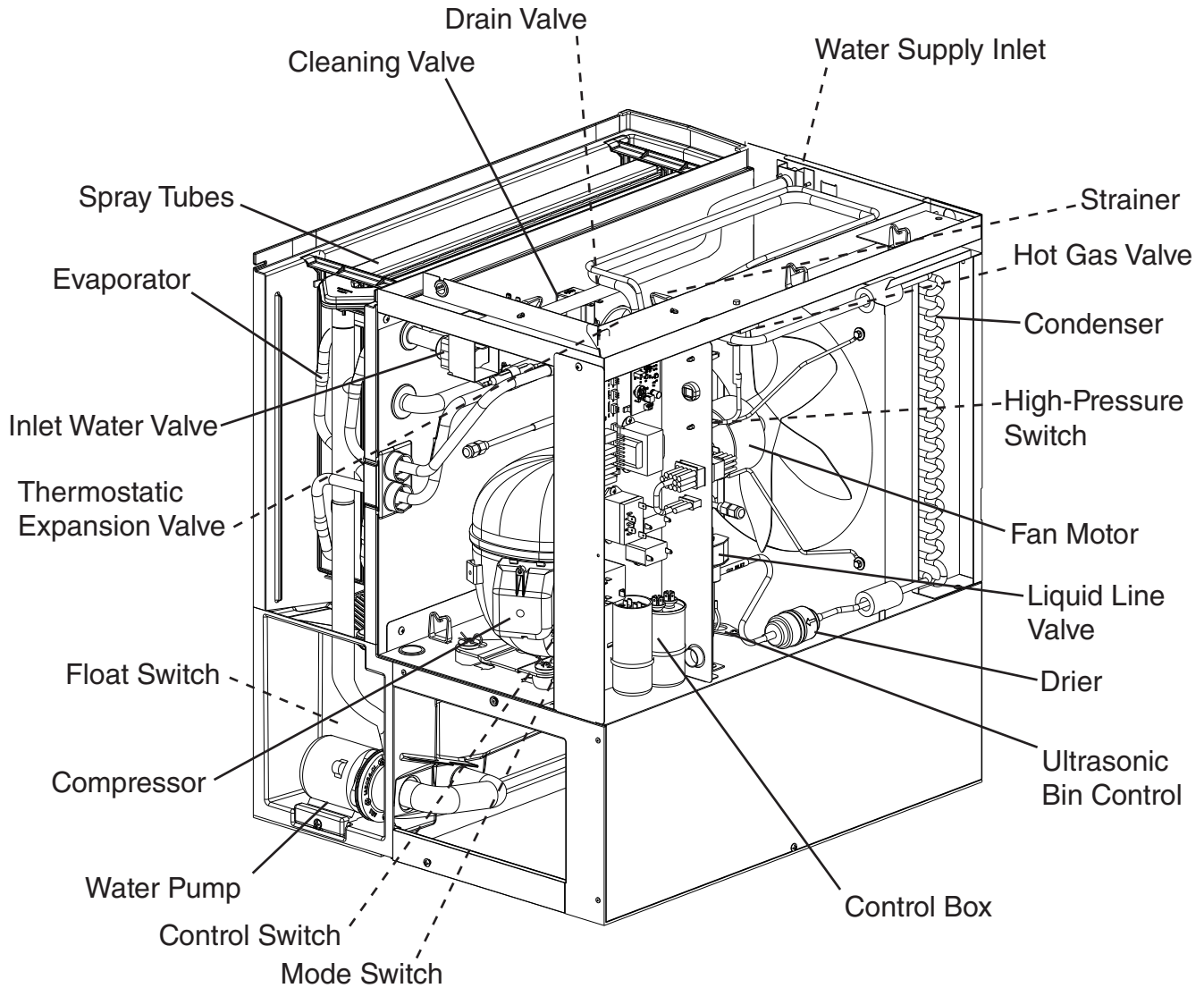

Model Shown: KM-520MAJ-E

# B. Water/Refrigeration Circuit Diagram

## 1. Air-Cooled Models (MAJ-E)

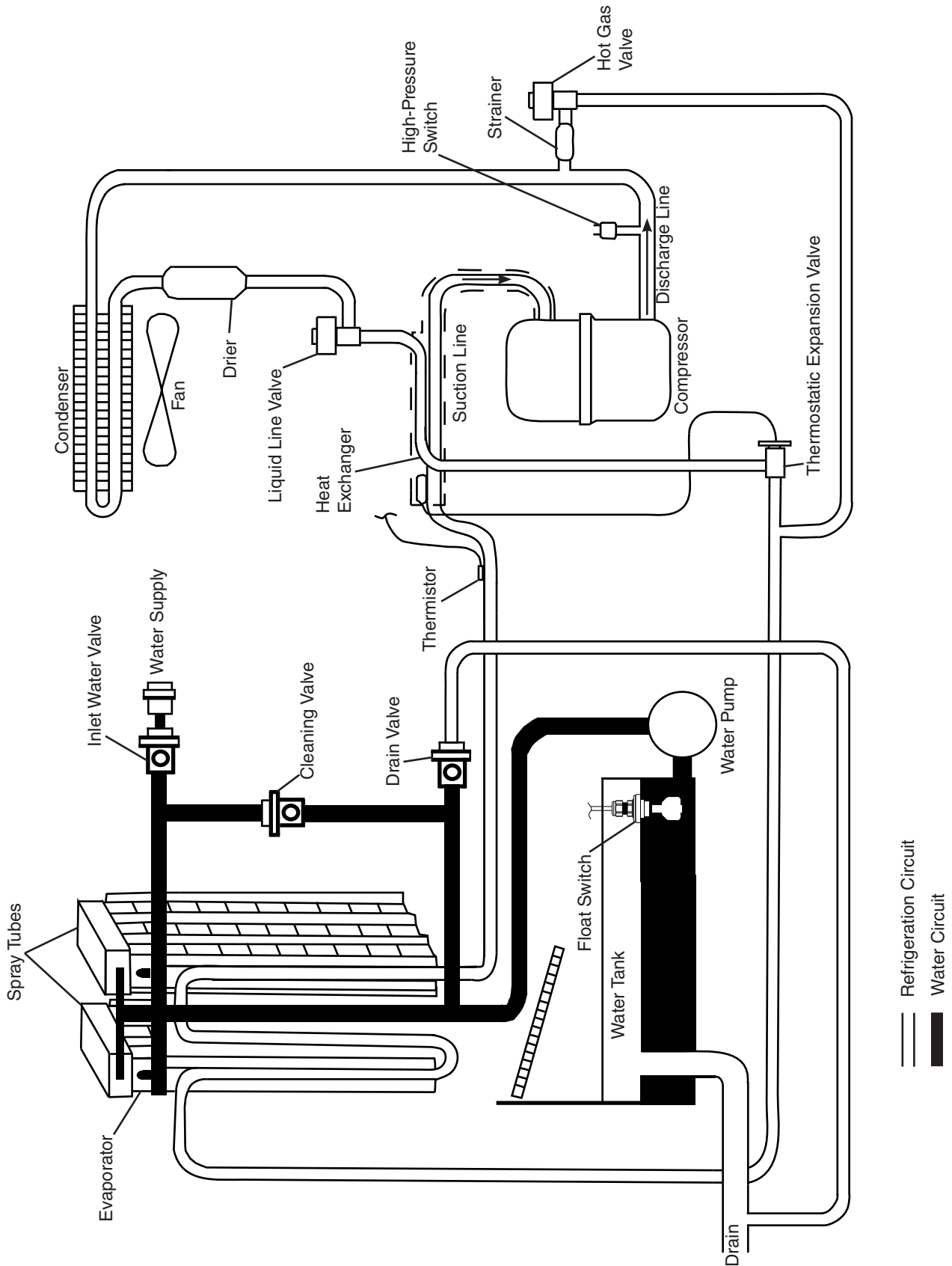



## II. Sequence of Operation and Service Diagnosis

### A. Sequence of Operation Flow Chart

#### 1. Operation Flow Chart

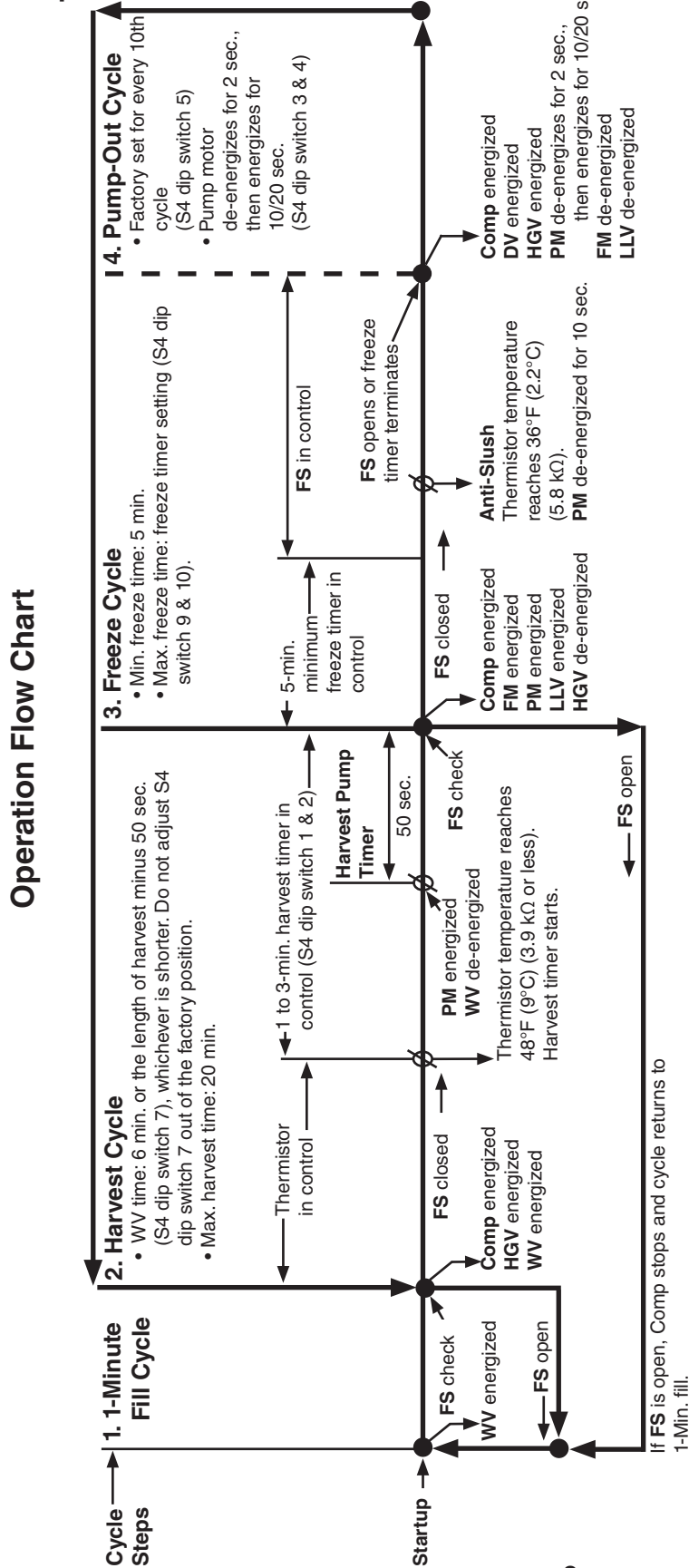

**Legend:**

- Comp—compressor
- DV—drain valve
- FM—fan motor
- FS—float switch
- HGV—hot gas valve
- LLV—liquid line valve
- PM—pump motor
- WV—inlet water valve

**Components Energized when the Control Switch is in the "PUMP" Position**

When the control switch is in the "PUMP" position, power is supplied to the pump motor. Water tank contents then flows over the outside of the evaporator plate assembly. Note: Water tank contents does not flow inbetween the evaporator plates.

**Components Energized when the Control Switch is in the "ON" or "PUMP" position and the Mode Switch is in the "CLEAN" Position**

- When the control switch is in the "ON" position and the mode switch is in the "CLEAN" position power is supplied to the control board K9 connector. The control board then initiates a clean/sanitize program. See the maintenance label on the top cover or the instruction manual for details.
- When the control switch is in the "PUMP" position and the mode switch is in the "CLEAN" position, only the pump motor energizes and circulates water tank contents over outside of evaporator plate assembly as the control board power supply has been disconnected. The Clean/Sanitize program cannot initiate in this scenario.

## 2. Shutdown Flow Chart

### Shutdown Flow Chart

#### K Control Board (2A8242-02)

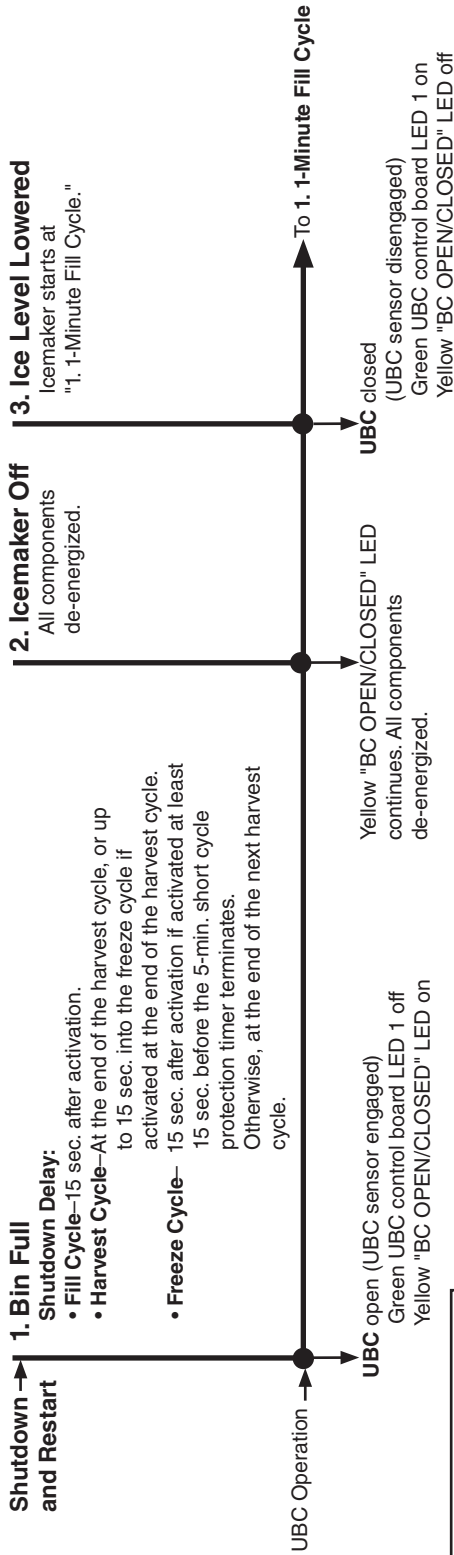

**Legend:**  
UBC—ultrasonic bin control

#### K+ Control Board (2A9678-01)

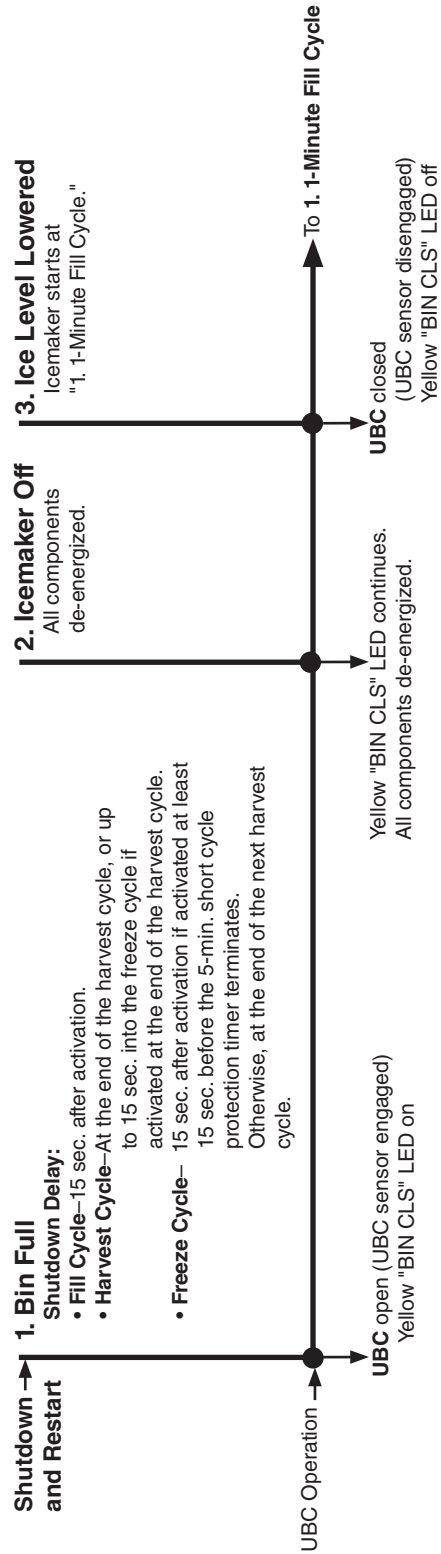

**Legend:**  
UBC—ultrasonic bin control

## B. Service Diagnosis

### 1. K Control Board (2A8242-02) with Ultrasonic Bin Control Used in conjunction with Ultrasonic Bin Control Board (4A6838-01)

**KM-550MAJ-E Auxiliary Code L-0(B) and Earlier**

**KM-660MAJ-E Auxiliary Code L-1(J) and Earlier**

#### **⚠ WARNING**

- The appliance should be diagnosed and repaired only by qualified service personnel to reduce the risk of death, electric shock, serious injury, or fire.
- Risk of electric shock. Control switch in "OFF" position does not de-energize all loads Use extreme caution and exercise safe electrical practices.
- Moving parts (e.g., fan blade) can crush and cut. Keep hands clear.
- Before servicing the appliance, move the control switch to the "OFF" position and turn off the power supply.
- **CHOKING HAZARD:** Ensure all components, fasteners, and thumbscrews are securely in place after the appliance is serviced. Make sure that none have fallen into the dispenser unit/ice storage bin.
- Make sure all food zones in the appliance and dispenser unit/ice storage bin are clean after service.

The diagnostic procedure is a sequence check that allows you to diagnose the electrical system and components. Before proceeding, check for correct installation, proper voltage per nameplate, and adequate water supply. Check CB using the steps in "II.C. Control Board Check." Check dip switch settings to assure that S4 dip switches and S5 dip switches 1 through 5 are in the factory default position. S4 dip switch 1, 2, 3, 4, and 5 are cleaning adjustments and the settings are flexible. For factory default settings, see "III.C.1. Default Dip Switch Settings."

Note: • When checking high voltage (230VAC), check electrical outlet power supply and confirm 13A power supply cord fuse is good.

- Main transformer; The 115VAC neutral (W) for components is provided through the main transformer. To confirm a good 115VAC neutral (W), check for 60VAC from white (W) neutral to ground/earth (GND (EARTH)). If 60VAC is present, main transformer and neutral is good. If 60VAC is not present, check 230VAC main power supply to the main transformer. If 230VAC is present at the electrical outlet, check power supply cord fuse and main transformer continuity.
- When checking component high voltage (115VAC), always choose a white (W) neutral wire to establish a good neutral connection.
- When checking voltage from the CB K1 connector (10 pin connector), pull CB K1 connector out slightly to allow room for multimeter test leads contact.

1) Remove the front panel, then move the control switch to the "OFF" position. Next, unplug the power supply cord from the electrical outlet. Access the control box and check that the 115VAC 10A fuse is good.

2) Clear ice from UBC sensing area.

## 1. Sequence and Component Diagnosis

- 3) **Power On:** Plug the power supply cord back into the electrical outlet, then move the control switch to the "ON" position and the mode switch to the "ICE" position. A 5-sec. delay occurs. CB red "POWER OK" LED turns on. If CB yellow "BC OPEN/CLOSED" LED is on (indicating a full bin), move ice away from UBC sensing area or see "II.D. Bin Control Check and Adjustment."

Note: • CB red "POWER OK" LED remains on unless the 10.5VAC power supply is interrupted (K2 connector).

- Check CB using the steps in "II.C. Control Board Check" or UBC using steps in "II.D. Bin Control Check and Adjustment."

- a) **Power On Diagnosis:** If CB red "POWER OK" LED is off, confirm 10A fuse is good. Check for 115VAC at control switch #2 (BK) to neutral (W) then at control switch #1 (P) to neutral (W). If 115VAC is present on #2 (BK) and not on #1 (P), replace control switch. If 115VAC is present on control switch #1 (P), check for 115VAC at HPS (P) to neutral (W) then HPS (BK) to neutral (W). If 115VAC is present at HPS (P) and not at HPS (BK), HPS is open. See HPS Diagnosis below. If 115VAC is present at HPS (BK), check for 10.5VAC at CB K2 #1 red wire to CB K2 #2 red wire. If 10.5VAC is not present, check CT continuity. If open, replace CT.
- b) **Power On Ultrasonic Bin Control Diagnosis:** If CB red "POWER OK" LED and CB "BC OPEN/CLOSED" LED are on, and UBC control board "LED 1" LED is off, clear UBC sensing area. If no object is in the area, replace UBC. If CB red "POWER OK" LED is on and CB "BC OPEN/CLOSED" LED and UBC control board "LED 1" LED are off, replace UBC control board. See "II.D. Ultrasonic Bin Control Check and Adjustment."

Note: UBC control board delay time:

**Sensing Ice:** UBC control board "LED 1" LED turns off and CB "BC OPEN/CLOSED" LED turns after 5-sec. delay.

**Not Sensing Ice:** UBC control board "LED 1" LED turns on and CB "BC OPEN/CLOSED" LED turns off after 30-sec. delay.

- c) **HPS Diagnosis:** Check that the condenser coil is not clogged or restricted. Let refrigeration circuit pressures equalize. If HPS does not reset and pressures are equalized, replace HPS. If pressures are not equalized, reclaim refrigerant and diagnose refrigeration circuit restriction. Check that there are no restrictions in the refrigeration circuit.

Harvest Cycle: HGV, strainer, or check valve.

Freeze Cycle: FM, TXV, LLV, strainer, check valve, and drier.

Confirm that the location meets installation requirements:

- The appliance is not intended for outdoor use. Normal operating ambient temperature should be within 45°F to 100°F (7°C to 38°C).
- Allow 6" (15 cm) clearance at rear, sides, and top for proper air circulation and ease of maintenance and/or service should they be required.
- The appliance should not be located in a corrosive environment.

- 4) **1-Min. Fill Cycle – LED 4 is on.** WV energizes. After 1 min., CB checks for a closed FS. If FS is closed, the harvest cycle begins. If harvest cycle begins (Comp and HGV energize), continue to step 5a. If FS is open, WV remains energized until FS closes (low water safety protection during initial start up and at the end of each harvest).  
**Diagnosis:** Check that water enters the water tank. If not, check that the water supply line shut-off valve is open and screens or external filters are clear. Check for 115VAC at CB K1 #6 (O) to neutral (W). If 115VAC is not present, replace CB. If 115VAC is present, and WV does not energize, check for 115VAC at WV. If 115VAC is present, check coil continuity. If open, replace WV. If the water tank fills, but the appliance fails to start harvest (Comp energized), check for open FS. See "II.E. Float Switch Check and Cleaning." If FS is closed and CB fails to start the harvest cycle after 1 min., replace CB.
- 5a) **Initial Harvest Cycle – LEDs 1, 4, and 2 are on.** WV continues. Comp and HGV energize. CB monitors the warming of the evaporator via the thermistor located on the suction line. When the thermistor reaches 48°F (9°C), CB reads 3.9 kΩ from the thermistor and turns harvest termination over to the harvest timer (S4 dip switch 1 & 2 and S5 dip switch 4). WV is energized during harvest for a maximum of 6 min. or the length of harvest minus HPT setting (S4 dip switch 6), whichever is shorter. See step 5b below.
- a) **Comp Diagnosis:** Check that evaporator is warming. If not, confirm that Comp energizes. If not, check for 115VAC at CB K1 #9 (Y) to neutral (W). If 115VAC is not present, check for 115VAC at CB K1 #10 (BK) to neutral (W). If 115VAC is present at #10 (BK) and not at #9 (Y), replace CB. If 115VAC is present, check for 115VAC at mode switch #2 (Y) to neutral and mode switch #1 (V) to neutral. If 115VAC is present at #2 (Y) and not at #1 (V), confirm mode switch is in "ICE" position. If in "ICE" position, check mode switch continuity. If open, replace mode switch. If 115VAC is present at mode switch #1 (V), check for 115VAC at CR solenoid. If 115VAC is present, confirm contacts are closed. If not, replace CR. If CR contacts are closed, check Comp external overload, Comp start and run capacitors, Comp start relay, and Comp motor winding.
- b) **HGV Diagnosis:** If Comp is energized and evaporator is not warming, check that HGV energizes and opens. Check for 115VAC at CB K1 #2 (P) to neutral (W). If 115VAC is not present, check for 115VAC at CB K1 #1 (V). If 115VAC is not present, check wiring for loose connection from CB 10 pin connector pin #1 (V) to mode switch. If 115VAC is present on #1 (V) and not at #2 (P), replace CB. If 115VAC is present at #2 (P), check for 115VAC at HGV coil and check HGV coil continuity. Replace as needed. Note: LED is off when HGV is energized and on when LLV/FM are energized.
- c) **LLV Diagnosis:** Confirm that LLV is de-energized and closed (not bypassing). If energized, replace CB. If de-energized and bypassing, replace LLV.

5b) **Harvest Pump Time (Harvest Assist) – LEDs 1 and 3 are on.** When the thermistor reaches 48°F (9°C), CB reads 3.9 kΩ from the thermistor and turns harvest termination over to the harvest timer (S4 dip switch 1 & 2 and S5 dip switch 4). When WV de-energizes, LED 4 turns off and LED 3 turns on. PM energizes. Comp and HGV continue.

**Diagnosis:** Place a thermometer on the suction line next to the thermistor. Has it warmed to 48°F (9°C) or warmer? Confirm thermistor status. See "II.F. Thermistor Check." If the thermistor reading is in proper range, dip switch 7 is on, and PM does not energize before harvest terminates, replace CB. If WV continues, check for 115VAC at CB K1 #6 (O). If 115VAC is present, and LED 4 is off, replace CB. If LED 3 is on and PM is not energized, check for 115VAC at CB K1 #4 (R). If 115VAC is not present, replace CB. If 115VAC is present and PM is not energized, check PM capacitor and motor winding continuity.

5c) **Initial Harvest Cycle Termination Diagnosis:** When the thermistor reaches 48°F (9°C), CB reads 3.9 kΩ from the thermistor and turns harvest termination over to the harvest timer (S4 dip switch 1 & 2 and S5 dip switch 4). Check discharge line temperature. For a thermistor check, see "II.F. Thermistor Check." If 1-min. fill cycle starts after harvest timer terminates, check that FS is clean and operating properly, see "II.E. Float Switch Check and Cleaning." If FS is closed, CB proceeds to the next cycle. If not, replace CB.

Note: The minimum total time allowed by CB for a complete harvest cycle is based on S5 dip switch 4. Maximum harvest time allowed is 20 min.

**NOTICE! S4 dip switch 7 must remain on. Otherwise, PM will not energize during the last seconds of harvest.**

6) **Freeze Cycle – LED 1, 2, and 3 are on.** Comp and PM continue. FM and LLV energize. HGV de-energizes. Appliance is held in freeze by a 5-min. short cycle protection timer. After 5-min. short cycle protection timer terminates and FS opens, freeze cycle terminates.

Note: PM power supply continues from CB K1 #4 (R) in harvest and in freeze.

**Anti-Slush:** When anti-slush is enabled (S5 dip switch 5 "ON"), PM de-energizes when thermistor reaches 36°F (2.2°C) (5.8 kΩ) for 10 sec. then, energizes for the remainder of the freeze cycle.

a) **Freeze Cycle Diagnosis:** Confirm Comp and PM continue. Confirm that FM and LLV energize. Next, confirm HGV de-energizes. During the first 5 min. of freeze, confirm evaporator is cooling. If not, confirm WV de-energized (not leaking by), HGV de-energized (not bypassing), LLV and FM energize, TXV operates correctly, Comp is efficient, and refrigerant charge is correct. See "VIII.A. Specification and Performance Data Sheets."



- b) **Comp Diagnosis:** If Comp de-energizes once freeze begins, check that appliance has not shut off on HPS (CB "POWER OK" LED off). If so, check "3)b) HPS Diagnosis" above. If CB "POWER OK" LED is on, check for 115VAC at CB K1 #9 (Y) to neutral (W). If 115VAC is not present and LED 1 is on, replace CB. If 115VAC is present, check for 115VAC at CR coil. If 115VAC is present, check CR coil and contact continuity. Replace as needed. If CR is okay, check Comp external overload, Comp start and run capacitors, Comp start relay, and Comp motor winding. If Comp is energized but evaporator is not cooling, check for an inefficient Comp. See "VIII.A. Specification and Performance Data Sheets."
- c) **WV and HGV Diagnosis:** If WV is energized, check for 115VAC at CB K1 #6 (O) to neutral (W). If 115VAC is present after PM energizes in harvest cycle, replace CB. If 115VAC is not present, replace WV (bypassing). If HGV did not de-energize at the end of harvest, check for 115VAC at CB K1 #2 (P) to neutral (W). If 115VAC is present and LED 2 is on, replace CB. If 115VAC is not present, replace HGV (bypassing).
- d) **PM Diagnosis:** Confirm water is flowing over evaporator from PM and not WV. If PM de-energizes once freeze begins, check for 115VAC at CB K1 #4 (R) to neutral (W). If 115VAC is not present, replace CB. If 115VAC is present and PM is de-energized, check PM capacitor and motor winding continuity. Except for 10 sec. anti-slush.
- e) **FM and LLV Diagnosis:** If FM or LLV does not energize, check for 115VAC at CB K1 #3 (BK) to neutral (W). If 115VAC is not present and LED 2 is on, check for 115VAC at CB K1 #1 (V). If 115VAC is present at #1 (V) and not at #3 (BK), replace CB. If 115VAC is present and LED 2 is on:  
 For FM, check capacitor, motor winding, and blade for binding.  
 For LLV, check coil voltage and continuity.  
 Note: LED 2 is on for LLV/FM and off for HGV.
- f) **Refrigerant Pressures and TXV Diagnosis:** If evaporator is still not cooling, check refrigerant pressures. See "VIII.A. Specification and Performance Data Sheets." Next, check TXV for proper operation. Remove TXV bulb and hold it in your hand, refrigerant low-side pressure should rise, place TXV bulb in ice water, refrigerant low-side pressure should drop. A 10 to 15 pound pressure swing between warm and cold conditions indicate a good TXV. If a 10 to 15 pound swing is not present, replace TXV.
- g) **Freeze Termination Diagnosis:** After 5 min. in freeze, disconnect CB K5 FS connector. 15 sec. later appliance should switch out of the freeze cycle (15 second delay after FS opens before terminating the freeze cycle). If appliance remains in freeze longer than 15 sec. after FS removed, replace CB. If appliance switches with FS removed but would previously not switch out of freeze with FS connected (long freeze - 3 beep alarm), see "II.E. Float Switch Check and Cleaning."

Note: Normal freeze cycle will last 20 to 40 min. depending on model and conditions. Cycle times and pressures should follow performance data provided in this manual. See "VIII.A. Specification and Performance Data Sheets."

h) **Short Freeze Cycle Diagnosis:** Confirm water tank fills and overflows during 1 min. fill and harvest cycles. If not, check water supply filters, shut-off valve, WV screen. If water tank empties before 5 min. timer terminates and freeze cycle is short, check that DV is not leaking by (water flowing down the drain). If DV is leaking by, remove and clean DV, replace if necessary. If water tank is full, see "II.E. Float Switch Check and Cleaning." for erratic operating FS.

7) **Pump-Out Cycle – LEDs 1, 3, and 5 are on (10/20 second pump-out).** Timing of the first pump-out is determined by S4 dip switch 5. See the table below.

| Control Board Settings |                    |                         |
|------------------------|--------------------|-------------------------|
| S4 Dip Switch Setting  | Pump-Out Frequency | Control Board           |
| No. 5                  |                    |                         |
| OFF                    | Every 10 cycles    | After 11th freeze cycle |
| ON                     | Every cycle        | After 2nd freeze cycle  |

Comp continues, HGV energizes.

Note: If S4 dip switch 3 & 4 are set to 3 off and 4 on, LED 4 turns on and WV energizes.

**NOTICE! S5 dip switch 1 must not be adjusted. This is the pump-out circulation selection and allows DV to energize in pump-out.**

FM and LLV de-energize. PM stops for 2 sec., then PM and DV energize for 10/20 sec. depending on pump-out timer (S4 dip switch 3 & 4) setting. When the pump-out timer terminates, pump-out is complete. The pump-out frequency control (S4 dip switch 5) is factory set, and generally no adjustment is required. However, the pump-out frequency control can be set to have a pump-out occur every 10 cycles or every cycle. For details, see "III.C.4. Pump-Out Frequency Control (S4 dip switch 5)."

**Pump-Out Diagnosis:** In the freeze cycle before pump-out (see table above), after 5 min. of freeze disconnect CB black K5 connector (FS connector). Check that PM stops and re-starts. Next, check that PM and DV energized (water flowing down the drain through DV). If PM does not stop and re-start, check that CB LEDs 1, 3, and 5 are on. If not, replace CB. If LEDs 1, 3, and 5 are on and PM does not energize, check for 115VAC at CB K1 #4 (R) to neutral (W). If 115VAC is not present, replace CB. If not, check PM motor windings and impeller for binding. If energized, make sure DV energized. If not, check for 115VAC at CB K1 #5 (W/BU). If 115VAC is not present and LED 5 is on, replace CB. If 115VAC is present, check DV solenoid continuity. Replace as needed. If DV is energized and open, check that the drain line is not clogged.

Confirm FM and LLV de-energize. If FM or LLV are energized with LEDs 1, 3, and 5 on, replace CB.

8) **Normal Harvest Cycle** – Same as the initial harvest cycle. Return to step 5a) above.

Note: Appliance continues to cycle until BC is satisfied or power is switched off.

The appliance always restarts at the 1-min. fill cycle.

## 2. Shutdown Diagnosis

1) See "II.D.1. Bin Control Check."

Legend: **CB**–control board; **Comp**–compressor; **CT**–control transformer; **DV**–drain valve; **FM**–fan motor; **FS**–float switch; **HGV**–hot gas valve; **HPS**–high-pressure switch; **LLV**–liquid line valve; **MT**–main transformer; **PM**–pump motor; **TXV**–thermostatic expansion valve; **UBC**–ultrasonic bin control; **WV**–inlet water valve



## 2. K+ Control Board (2A9678-01) with Ultrasonic Bin Control

KM-550MAJ-E Auxiliary Code L-0(C) and Later

KM-660MAJ-E Auxiliary Code L-1(K) and Later

### **WARNING**

- The appliance should be diagnosed and repaired only by qualified service personnel to reduce the risk of death, electric shock, serious injury, or fire.
- Risk of electric shock. Control switch in "OFF" position does not de-energize all loads Use extreme caution and exercise safe electrical practices.
- Moving parts (e.g., fan blade) can crush and cut. Keep hands clear.
- Before servicing the appliance, move the control switch to the "OFF" position and turn off the power supply.
- **CHOKING HAZARD:** Ensure all components, fasteners, and thumbscrews are securely in place after the appliance is serviced. Make sure that none have fallen into the dispenser unit/ice storage bin.
- Make sure all food zones in the appliance and dispenser unit/ice storage bin are clean after service.

The diagnostic procedure is a sequence check that allows you to diagnose the electrical system and components. Before proceeding, check for correct installation, proper voltage per nameplate, and adequate water supply. Check CB using the steps in "II.C. Control Board Check." Check dip switch settings to assure that S4 dip switches and S5 dip switches 1 through 5 are in the factory default position. S4 dip switch 1, 2, 3, 4, and 5 are cleaning adjustments and the settings are flexible. For factory default settings, see "III.C.1. Default Dip Switch Settings."

Note: • When checking high voltage (230VAC), check electrical outlet power supply and confirm 13A power supply cord fuse is good.

- Main transformer; The 115VAC neutral (W) for components is provided through the main transformer. To confirm a good 115VAC neutral (W), check for 60VAC from white (W) neutral to ground/earth (GND (EARTH)). If 60VAC is present, main transformer and neutral is good. If 60VAC is not present, check 230VAC main power supply to the main transformer. If 230VAC is present at the electrical outlet, check power supply cord fuse and main transformer continuity.
- When checking component high voltage (115VAC), always choose a white (W) neutral wire to establish a good neutral connection.
- When checking voltage from the CB K1 connector (10 pin connector), pull CB K1 connector out slightly to allow room for multimeter test leads contact.

1) Remove the front panel, then move the control switch to the "OFF" position. Next, unplug the power supply cord from the electrical outlet. Access the control box and check that the 115VAC 10A fuse is good.

2) Clear ice from UBC sensing area.

## a) Sequence and Component Diagnosis

- 3) **Power On:** Plug the power supply cord back into the electrical outlet, then move the control switch to the "ON" position and the mode switch to the "ICE" position. A 5-sec. delay occurs. CB red "POWER OK" LED turns on. If CB yellow "BIN CLS" LED is on (indicating a full bin), move ice away from UBC sensing area or see "II.D. Bin Control Check and Adjustment."

Note: • CB red "POWER OK" LED remains on unless the 10.5VAC power supply is interrupted (K2 connector).

- Check CB using the steps in "II.C. Control Board Check" or UBC using steps in "II.D. Bin Control Check and Adjustment."

- a) **Power On Diagnosis:** If CB red "POWER OK" LED is off, confirm 10A fuse is good. Check for 115VAC at control switch #2 (BK) to neutral (W) then at control switch #1 (P) to neutral (W). If 115VAC is present on #2 (BK) and not on #1 (P), replace control switch. If 115VAC is present on control switch #1 (P), check for 115VAC at HPS (P) to neutral (W) then HPS (BK) to neutral (W). If 115VAC is present at HPS (P) and not at HPS (BK), HPS is open. See HPS Diagnosis below. If 115VAC is present at HPS (BK), check for 10.5VAC at CB K2 #1 red wire to CB K2 #2 red wire. If 10.5VAC is not present, check CT continuity. If open, replace CT.

- b) **Power On Ultrasonic Bin Control Diagnosis:** If CB red "POWER OK" LED and CB "BIN CLS" LED are on, clear UBC sensing area. If no object is in the area, replace UBC. If CB red "POWER OK" LED is on and CB "BIN CLS" LED is off, replace UBC control board. See "II.D. Ultrasonic Bin Control Check and Adjustment."

Note: UBC control board delay time:

**Sensing Ice:** CB "BIN CLS" LED turns on after 5-sec. delay.

**Not Sensing Ice:** CB "BIN CLS" LED turns off after 30-sec. delay.

- c) **HPS Diagnosis:** Check that the condenser coil is not clogged or restricted. Let refrigeration circuit pressures equalize. If HPS does not reset and pressures are equalized, replace HPS. If pressures are not equalized, reclaim refrigerant and diagnose refrigeration circuit restriction. Check that there are no restrictions in the refrigeration circuit.

Harvest Cycle: HGV, strainer, or check valve.

Freeze Cycle: FM, TXV, LLV, strainer, check valve, and drier.

Confirm that the location meets installation requirements:

- The appliance is not intended for outdoor use. Normal operating ambient temperature should be within 45°F to 100°F (7°C to 38°C).
- Allow 6" (15 cm) clearance at rear, sides, and top for proper air circulation and ease of maintenance and/or service should they be required.
- The appliance should not be located in a corrosive environment.

- 4) **1-Min. Fill Cycle – WV LED is on.** WV energizes. After 1 min., CB checks for a closed FS. If FS is closed, the harvest cycle begins. If harvest cycle begins (Comp, HGV, FMR energized), continue to step 5a. If FS is open, fill cycle continues until FS closes (low water safety protection during initial start up and at the end of each harvest).  
**Diagnosis:** Check that water enters the water tank. If not, check that the water supply line shut-off valve is open and screens or external filters are clear. Check for 115VAC at CB K1 #6 (O) to neutral (W). If 115VAC is not present, replace CB. If 115VAC is present, and WV does not energize, check for 115VAC at WV. If 115VAC is present, check coil continuity. If open, replace WV. If the water tank fills, but the appliance fails to start harvest (Comp energized), check for open FS. See "II.E. Float Switch Check and Cleaning." If FS is closed and CB fails to start the harvest cycle after 1 min., replace CB.
- 5a) **Initial Harvest Cycle – Comp, WV, and FM/HGV LEDs are on.** WV continues. Comp, FMR, and HGV energize. CB monitors the warming of the evaporator via the thermistor located on the suction line. When the thermistor reaches 48°F (9°C), CB reads 3.9 kΩ from the thermistor and turns harvest termination over to the harvest timer (S4 dip switch 1 & 2 and S5 dip switch 4). WV is energized during harvest for a maximum of 6 min. or the length of harvest minus HPT setting (S4 dip switch 6), whichever is shorter. See step 5b below.
- a) **Comp Diagnosis:** Check that evaporator is warming. If not, confirm that Comp energizes. If not, check for 115VAC at CB K1 #9 (Y) to neutral (W). If 115VAC is not present, check for 115VAC at CB K1 #10 (BK) to neutral (W). If 115VAC is present at #10 (BK) and not at #9 (Y), replace CB. If 115VAC is present, check for 115VAC at mode switch #2 (Y) to neutral and mode switch #1 (V) to neutral. If 115VAC is present at #2 (Y) and not at #1 (V), confirm mode switch is in "ICE" position. If in "ICE" position, check mode switch continuity. If open, replace mode switch. If 115VAC is present at mode switch #1 (V), check for 115VAC at CR solenoid. If 115VAC is present, confirm contacts are closed. If not, replace CR. If CR contacts are closed, check Comp external overload, Comp start and run capacitors, Comp start relay, and Comp motor winding.
- b) **HGV Diagnosis:** If Comp is energized and evaporator is not warming, check that HGV energizes and opens. Check for 115VAC at CB K1 #2 (P) to neutral (W). If 115VAC is not present, check for 115VAC at CB K1 #1 (V). If 115VAC is not present, check wiring for loose connection from CB 10 pin connector pin #1 (V) to mode switch. If 115VAC is present on #1 (V) and not at #2 (P), replace CB. If 115VAC is present at #2 (P), check for 115VAC at HGV coil and check HGV coil continuity. Replace as needed.
- c) **LLV Diagnosis:** Confirm that LLV is de-energized and closed (not bypassing). If energized, replace CB. If de-energized and bypassing, replace LLV.
- d) **WRV Diagnosis:** Confirm WRV is not leaking by. If WRV is leaking by, confirm HGV is open and LLV is closed. Next, check for proper refrigerant pressures. If refrigerant pressures are correct, adjust or replace WRV. See "IV.C. Water Regulating Valve Adjustment (water-cooled models)."

**5b) Harvest Pump Time (Harvest Assist) – Comp, PM, and FM/HGV LEDs are on.**

When the thermistor reaches 48°F (9°C), CB reads 3.9 kΩ from the thermistor and turns harvest termination over to the harvest timer (S4 dip switch 1 & 2 and S5 dip switch 4). When WV de-energizes, WV LED turns off and PM LED turns on. PM energizes. Comp, FMR, and HGV continue.

**Diagnosis:** Place a thermometer on the suction line next to the thermistor. Has it warmed to 48°F (9°C) or warmer? Confirm thermistor status. See "II.F. Thermistor Check." If the thermistor reading is in proper range, dip switch 7 is on, and PM does not energize before harvest terminates, replace CB. If WV continues, check for 115VAC at CB K1 #6 (O). If 115VAC is present, and WV LED is off, replace CB. If PM LED is on and PM is not energized, check for 115VAC at CB K1 #4 (R). If 115VAC is not present, replace CB. If 115VAC is present and PM is not energized, check PM capacitor and motor winding continuity.

**5c) Initial Harvest Cycle Termination Diagnosis:** When the thermistor reaches 48°F (9°C), CB reads 3.9 kΩ from the thermistor and turns harvest termination over to the harvest timer (S4 dip switch 1 & 2 and S5 dip switch 4). Check discharge line temperature. For a thermistor check, see "II.F. Thermistor Check." If 1-min. fill cycle starts after harvest timer terminates, check that FS is clean and operating properly, see "II.E. Float Switch Check and Cleaning." If FS is closed, CB proceeds to the next cycle. If not, replace CB.

Note: The minimum total time allowed by CB for a complete harvest cycle is based on S5 dip switch 4. Maximum harvest time allowed is 20 min.

**NOTICE! S4 dip switch 7 must remain on. Otherwise, PM will not energize during the last seconds of harvest.**

**6) Freeze Cycle – Comp and PM LEDs are on.** Comp, FMR, and PM continue. FM and LLV energize. HGV de-energizes. Appliance is held in freeze by a 5-min. short cycle protection timer. After 5-min. short cycle protection timer terminates and FS opens, freeze cycle terminates.

Note: PM power supply continues from CB K1 #4 (R) in harvest and in freeze.

**Anti-Slush:** When anti-slush is enabled (S5 dip switch 5 "ON"), PM de-energizes when thermistor reaches 36°F (2.2°C) (5.8 kΩ) for 10 sec. then, energizes for the remainder of the freeze cycle.

**a) Freeze Cycle Diagnosis:** Confirm Comp, FMR, and PM continue. Confirm that FM and LLV energize. Confirm WRV opens. Next, confirm HGV de-energizes. During the first 5 min. of freeze, confirm evaporator is cooling. If not, confirm WV de-energized (not leaking by), HGV de-energized (not bypassing), LLV and FM energize, TXV and HM operate correctly, WRV opens, Comp is efficient, and refrigerant charge is correct. See "VIII.A. Specification and Performance Data Sheets."

- b) **Comp and FMR Diagnosis:** If Comp and FMR de-energize once freeze begins, check that appliance has not shut off on HPS (CB "POWER OK" LED off). If so, check "3)b HPS Diagnosis" above. If CB "POWER OK" LED is on, check for 115VAC at CB K1 #9 (Y) to neutral (W). If 115VAC is not present and Comp LED is on, replace CB. If 115VAC is present, check for 115VAC at CR coil. If 115VAC is present, check CR coil and contact continuity. Replace as needed. If CR is okay, check Comp start relay and start and run capacitors. Next, check Comp motor winding continuity. If Comp is energized but evaporator is not cooling, check for an inefficient Comp. See "VIII.A. Specification and Performance Data Sheets." If Comp is energized but FMR is not, check for 115VAC at the FMR junction box. If 115VAC is not present, check icemaker wiring connections. If 115VAC is present, check for voltage at condenser unit. If 115VAC is not present, check field wiring connections. If 115VAC is present, check FMR capacitor, motor winding, and fan blade for binding.
- c) **WV and HGV Diagnosis:** If WV is energized, check for 115VAC at CB K1 #6 (O) to neutral (W). If 115VAC is present after PM energizes in harvest cycle, replace CB. If 115VAC is not present, replace WV (bypassing). If HGV did not de-energize at the end of harvest, check for 115VAC at CB K1 #2 (P) to neutral (W). If 115VAC is present at CB K1 #2 (P) and FM/HGV LED is off, replace CB. If 115VAC is not present at CB K1 #2 (P), replace HGV (bypassing).
- d) **PM Diagnosis:** Confirm water is flowing over evaporator from PM and not WV. If PM de-energizes once freeze begins, check for 115VAC at CB K1 #4 (R) to neutral (W). If 115VAC is not present, replace CB. If 115VAC is present and PM is de-energized, check PM capacitor and motor winding continuity.
- e) **FM and LLV Diagnosis:** If FM or LLV does not energize, check for 115VAC at CB K1 #3 (BK) to neutral (W). If 115VAC is not present and FM/HGV LED is off, check for 115VAC at CB K1 #1 (V). If 115VAC is present at #1 (V) and not at #3 (BK), replace CB. If 115VAC is present at #3 (BK) and FM/HGV LED is off:  
 For FM, check capacitor, motor winding, and blade for binding.  
 For LLV, check coil voltage and continuity.  
 Note: FM is OFF when FM/HGV LED is ON.
- f) **Refrigerant Pressures, HM, and TXV Diagnosis:** If evaporator is still not cooling, check refrigerant pressures. See "VIII.A. Specification and Performance Data Sheets."  
 Next, check HM operation. If refrigeration pressures are above HM setpoint and HM is bypassing, replace HM. Check TXV for proper operation. Remove TXV bulb and hold it in your hand, refrigerant low-side pressure should rise, place TXV bulb in ice water, refrigerant low-side pressure should drop. A 10 to 15 pound pressure swing between warm and cold conditions indicate a good TXV. If a 10 to 15 pound swing is not present, replace TXV.



- g) **WRV Diagnosis:** WRV is factory set and generally no adjustment is required. If WRV fails to open in freeze, check for proper refrigerant pressures. See "VIII.A. Specification and Performance Data Sheets." If refrigerant pressures are correct and WRV does not open, adjust or replace as needed. See "IV.C. Water Regulating Valve Adjustment (water-cooled models)."
- h) **Freeze Termination Diagnosis:** After 5 min. in freeze, disconnect CB K5 FS connector. 15 sec. later appliance should switch out of the freeze cycle (15 second delay after FS opens before terminating the freeze cycle). If appliance remains in freeze longer than 15 sec. after FS removed, replace CB. If appliance switches with FS removed but would previously not switch out of freeze with FS connected (long freeze - 3 beep alarm), see "II.E. Float Switch Check and Cleaning."

Note: Normal freeze cycle will last 20 to 40 min. depending on model and conditions. Cycle times and pressures should follow performance data provided in this manual. See "VIII.A. Specification and Performance Data Sheets."

- i) **Short Freeze Cycle Diagnosis:** Confirm water tank fills and overflows during 1 min. fill and harvest cycles. If not, check water supply filters, shut-off valve, WV screen. If water tank empties before 5 min. timer terminates and freeze cycle is short, check that DV is not leaking by (water flowing down the drain). If DV is leaking by, remove and clean DV, replace if necessary. If water tank is full, see "II.E. Float Switch Check and Cleaning." for erratic operating FS.

7) **Pump-Out Cycle – Comp, PM, FM/HGV, and DV LEDs are on (10/20 second pump-out).** Timing of the first pump-out is determined by S4 dip switch 5. See the table below.

| Control Board Settings |                    |                         |
|------------------------|--------------------|-------------------------|
| S4 Dip Switch Setting  | Pump-Out Frequency | 1st Pump-Out            |
| No. 5                  |                    |                         |
| OFF                    | Every 10 cycles    | After 11th freeze cycle |
| ON                     | Every cycle        | After 2nd freeze cycle  |

Comp and FMR continue, HGV energizes.

Note: If S4 dip switch 3 & 4 are set to 3 off and 4 on, WV LED turns on and WV energizes. **NOTICE! S5 dip switch 1 must not be adjusted. This is the pump-out circulation selection and allows DV to energize in pump-out.**

FM and LLV de-energize. PM stops for 2 sec., then PM and DV energize for 10/20 sec. depending on pump-out timer (S4 dip switch 3 & 4) setting. When the pump-out timer terminates, pump-out is complete. The pump-out frequency control (S4 dip switch 5) is factory set, and generally no adjustment is required. However, the pump-out frequency control can be set to have a pump-out occur every 10 cycles or every cycle. For details, see "III.C.4. Pump-Out Frequency Control (S4 dip switch 5)."

**Pump-Out Diagnosis:** In the freeze cycle before pump-out (see table above), after 5 min. of freeze disconnect CB black K5 connector (FS connector). Check that PM stops and re-starts. Next, check that PM and DV energized (water flowing down the drain through DV). If PM does not stop and re-start, check that CB Comp, PM, and DV LEDs are on. If not, replace CB. If Comp, PM, and DV LEDs are on and PM does not energize, check for 115VAC at CB K1 #4 (R) to neutral (W). If 115VAC is not present, replace CB. If not, check PM motor windings and impeller for binding. If energized, make sure DV energized. If not, check for 115VAC at CB K1 #5 (W/BU). If 115VAC is not present and DV LED is on, replace CB. If 115VAC is present, check DV solenoid continuity. Replace as needed. If DV is energized and open, check that the drain line is not clogged.

Confirm FM and LLV de-energize. If FM or LLV are energized with Comp, PM, and DV LEDs on, replace CB.

8) **Normal Harvest Cycle** – Same as the initial harvest cycle. Return to step 5a) above.

Note: Appliance continues to cycle until BC is satisfied or power is switched off.

The appliance always restarts at the 1-min. fill cycle.

## b) Shutdown Diagnosis

1) See "II.D.1. Bin Control Check."

Legend: **CB**—control board; **Comp**—compressor; **CR**—compressor relay;

**CT**—control transformer; **CV**—cleaning valve; **DV**—drain valve;

**FM**—fan motor; **FMR**—fan motor remote; **FS**—float switch; **HGV**—hot gas valve;

**HM**—headmaster (C.P.R.); **HPS**—high-pressure switch; **HPT**—harvest pump time;

**LLV**—liquid line valve; **PM**—pump motor; **TXV**—thermostatic expansion valve;

**UBC**—ultrasonic bin control; **WV**—inlet water valve

### C. Control Board Check

Before replacing CB that does not show a visible defect and that you suspect is bad, always conduct the following check procedure. This procedure will help you verify your diagnosis.

Alarm Reset: If CB is in alarm (beeping), press the "ALARM RESET" button on CB while CB is beeping. **WARNING! Risk of electric shock. Care should be taken not to touch live terminals.** Once reset, the icemaker starts at the 1-minute fill cycle. For audible alarm information, see "III.B. LED Lights and Audible Alarm Safeties."

- 1) Check the dip switch settings to assure that S4 dip switch 3, 4, 7, 8, 9, 10 and S5 dip switch 1 through 5 are in the factory default position. S4 dip switch 1, 2, 5, and 6 are cleaning adjustments and the settings are flexible. For factory default settings, see "III.C.1. Default Dip Switch Settings."
- 2) Move the control switch to the "ON" position and the mode switch to the "ICE" position. If the red CB "POWER OK" LED is on, control voltage is good, continue to step 3. If CB "POWER OK" LED is off, check MT primary circuit and CT secondary circuit. CT output is 10.5VAC at 115VAC primary input. If the secondary circuit has proper voltage and the red LED is off, replace CB.

If the secondary circuit does not have proper voltage, check incoming power supply circuit (power supply, power supply cord fuse, MT, 10A fuse, and CT primary circuit). Check for 115VAC at CB K1 connector pin #10 (BK) to neutral (W) for 115VAC. Always choose a white (W) neutral wire to establish a good neutral connection when checking voltages. For additional checks, see "II.I.1. No Ice Production."

- 3a) **K Control Board (2A8242-02)** - The "OUTPUT TEST" button provides a relay sequence test. Make sure the control switch is in the "ON" position and the mode switch is in the "ICE" position, then press the "OUTPUT TEST" button. For the correct lighting sequence, see "B. LED Lights and Audible Alarm Safeties." Note that the order of the LEDs from the outer edge of the control board is 1, 4, 5, 3, 2. Components (e.g., compressor) cycle during the test. See Fig. 1.

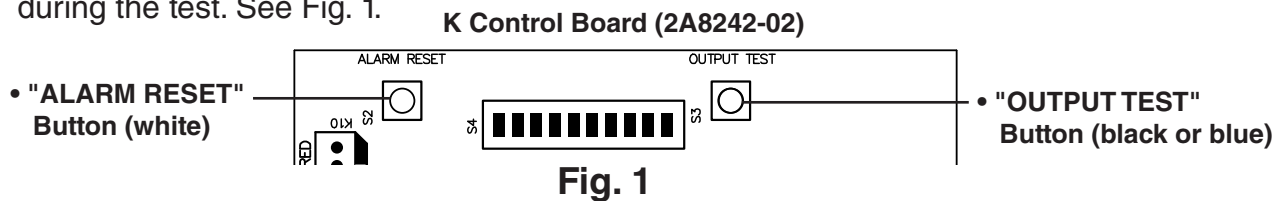

- 3b) **K+ Control Board (2A9678-01)** - The "OUTPUT TEST" button provides a relay sequence test. Make sure the control switch is in the "ON" position and the mode switch is in the "ICE" position, then press the "OUTPUT TEST" button. For the correct lighting sequence, see "B. LED Lights and Audible Alarm Safeties." Note that the order of the LEDs from the outer edge of the control board is Comp, CV, WV, DV, PM, FM/HGV. Components cycle during the test. See Fig. 2.

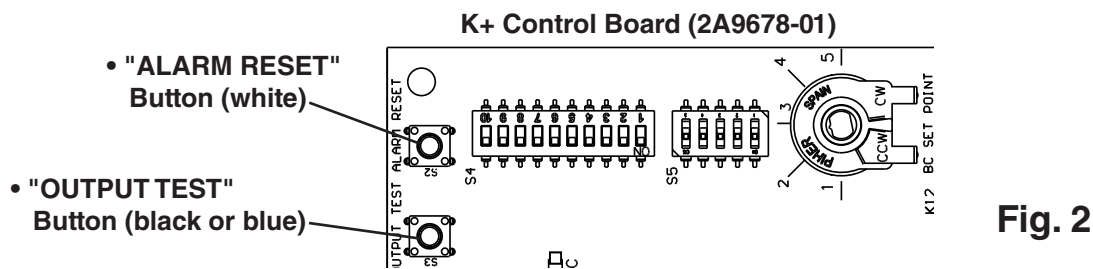



Following the test, the icemaker begins operation at the 1-minute fill cycle. If the LEDs do not light as described above, replace CB.

- 4) To verify voltage output from CB to the components, slide the CB K1 connector out far enough to allow multimeter lead contact. With the icemaker in the cycle to be tested, check output voltage from the corresponding pin on CB K1 connector to a neutral (W wire). If output voltage is not found and the appropriate LED is on, replace CB.
- 5) Check CB control connectors K3, K4, and K5 for correct VDC per table below.  
Note: Pin #1 is DC ground (GND) on each connector

Legend: **CB**–control board; **CT**–control transformer

### K Control Board (2A8242-02)

| K3 Thermistor |      | K4 Ultrasonic Control Board |      | K5 Float Switch |        |
|---------------|------|-----------------------------|------|-----------------|--------|
| Pin #         | VDC  | Pin #                       | VDC  | Pin #           | VDC    |
| #1 to #2      | 5VDC | #1 to #2                    | 5VDC | #1 to #2        | 1.2VDC |
| #1 to #3      | 5VDC | #1 to #3                    | 5VDC | #1 to #3        | 2VDC   |
| #2 to #3      | 0VDC | #2 to #3                    | 0VDC | #2 to #3        | 1.2VDC |

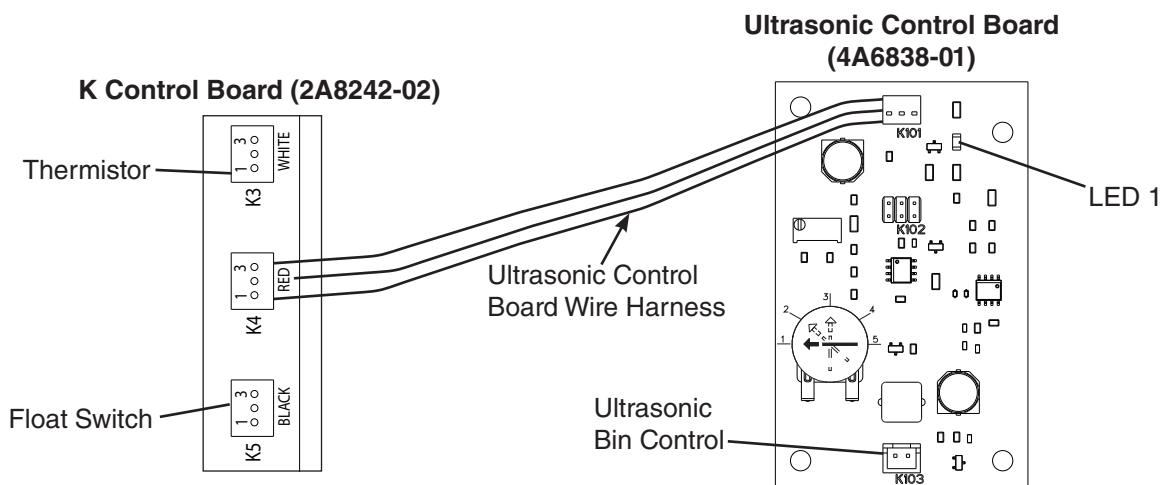

Fig. 3

### K+ Control Board (2A9678-01)

| K5 Float Switch |        | K3 Thermistor |      | K12 Ultrasonic Bin Control |     |
|-----------------|--------|---------------|------|----------------------------|-----|
| Pin #           | VDC    | Pin #         | VDC  | Pin #                      | VDC |
| #1 to #2        | 1.2VDC | #1 to #2      | 5VDC | #1 to #2                   | TBD |
| #1 to #3        | 2VDC   | #1 to #3      | 5VDC | #1 to #3                   | TBD |
| #2 to #3        | 1.2VDC | #2 to #3      | 0VDC | #2 to #3                   | TBD |

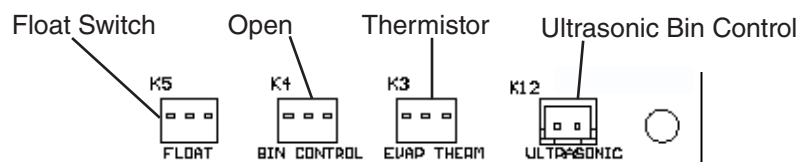

Fig. 4

## D. Bin Control Check and Adjustment

### ⚠ WARNING

- All parts are factory-adjusted. Improper adjustments may adversely affect safety, performance, component life, and warranty coverage.
- In Hoshizaki DB and DM dispenser applications, the bin control controller setting must be adjusted to 2. For Coca-Cola Freestyle® Dispenser and other dispenser applications, the bin control controller setting must be adjusted to 3. Increasing the ice level on any dispenser application could lead to icemaker movement, water leakage, or ice overflow.
- Be sure control switch is in "OFF" position and components (fan blade) have stopped moving before attempting to remove or replace the ultra sonic bin control sensor.

### NOTICE

- Do not block the bin control lens with top kits or the icemaker will not operate properly.
- Failure to properly adjust the bin control setting could result in water leakage, ice backup, and icemaker damage.

### 1. Bin Control Check

Before replacing UBC sensor and CB(s) that does not show a visible defect and you suspect is bad, always conduct the following check procedure. This procedure will help you verify your diagnosis. Note: It is strongly advised to keep a known "good" UBC sensor on your truck, for troubleshooting assistance.

The ultrasonic bin control is factory set for use on Hoshizaki America standard ice storage bins. If mounted on a dispenser application or if a change to the ice level in an ice storage bin application is desired, see "II.D.2. Bin Control Adjustment."

- 1) Remove the front panel. Move the control switch to the "OFF" position, then remove right side panel, and base cover. See Fig. 5.
- 2) Clear ice away from UBC area and confirm that the UBC lens is clean.
- 3) Place the mode switch in the "ICE" position, then move the control switch to the "ON" position. See Fig. 6.

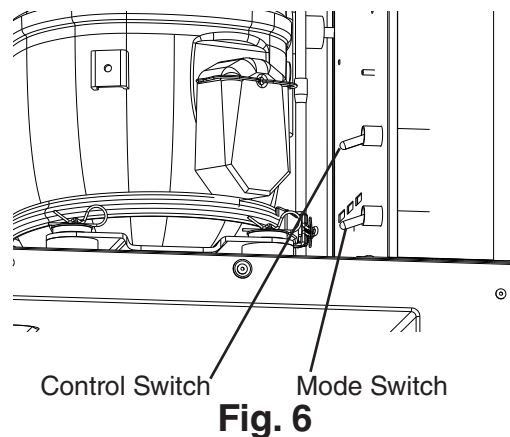
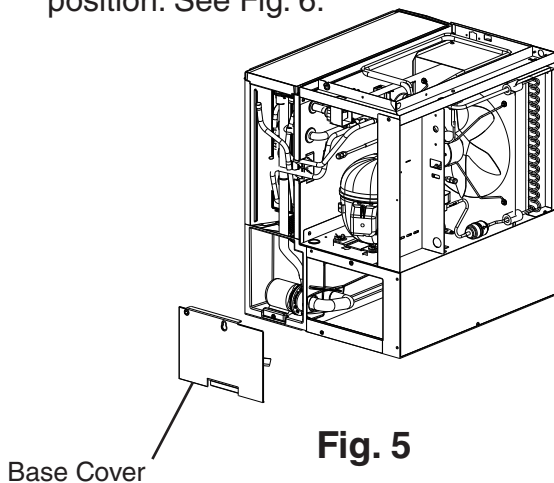

4a) **K Control Board (2A8242-02)** - UBC control board green "LED 1" LED is on and CB yellow "BC OPEN/CLOSED" LED is off.

- a) **Bin Empty Diagnosis:** If fill cycle does not start, confirm UBC control board green "LED 1" LED is on. If not, with UBC wire harness connected to CB K4 connector, check for 5VDC at CB K4 pin #3 (W) to CB K4 pin #2 (BK). If 5VDC is not present, replace CB. If 5VDC is present, check that the UBC wire harness is connected to the UBC control board. If the UBC control board green "LED 1" LED is off, replace UBC and UBC control board. If UBC control board green "LED 1" LED is on and icemaker does not start, check for 1VDC at CB K4 pin #1 (R) to CB K4 pin #2 (BK). If 1VDC is present, replace CB. If 4VDC is present, confirm no object is obstructing UBC lens. If no obstruction, replace UBC and UBC control board.

| Control Board K4 Bin Control Connector |            |      |
|--|------------|------|
| Bin Empty (closed)                     |            |      |
| Pin #                                  | Wire Color | VDC  |
| #1 to #2                               | R to BK    | 1VDC |
| #1 to #3                               | R to W     | 5VDC |
| #2 to #3                               | BK to W    | 5VDC |

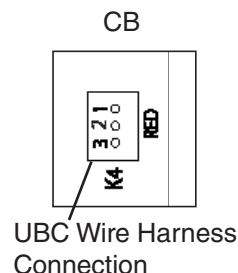

- b) As water begins to fill the water tank (1-min. fill), place an object 5" to 7" (127 to 178 mm) away from the UBC lens. See Fig. 7a. UBC control board 5-sec. delay timer starts. UBC control board 5-sec. delay timer terminates, green "LED 1" LED turns off and CB "BC OPEN/CLOSED" LED turns on. CB 15-sec. delay timer starts. CB 15-sec. delay timer terminates and the icemaker shuts down. Remove the object from the UBC lens. UCB control board 30-sec. delay timer starts. UCB control board 30-sec. delay timer terminates, CB "BC OPEN/CLOSED" LED turns off, UBC control board green "LED 1" LED turns on, and the icemaker restarts. Note: In some cases, removing the UBC sensor and rotating the UBC lens up and down, provides better access when troubleshooting.

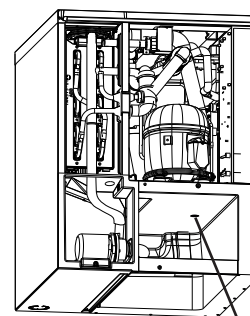

**Fig. 7a** Bin Control Lens

4b) **K+ Control Board (2A9678-01)** - CB yellow "BIN CLS" LED is off.

- a) **Bin Empty Diagnosis:** As water begins to fill the water tank (1-min. fill), place an object 5" to 7" (127 to 178 mm) away from the UBC lens. See Fig. 7b. CB 5-sec. delay timer starts. "BIN CLS" LED turns on. CB 5-sec. delay timer terminates, CB 15-sec. delay timer starts. CB 15-sec. delay timer terminates and the icemaker shuts down. Remove the object from the UBC lens. CB 30-sec. delay timer starts. CB 30-sec. delay timer terminates, CB "BIN CLS" LED turns off, and the icemaker restarts. Note: In some cases, removing the UBC sensor and rotating the UBC lens up and down, provides better access when troubleshooting.

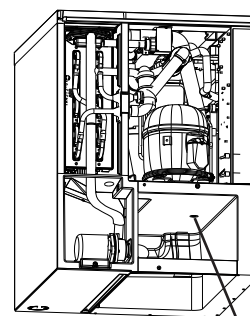

**Fig. 7b** Bin Control Lens

|  |  |
|--|--|
| <b>Cycle at Bin Control Activation</b> | <b>Control Board Shutdown</b>  |
| Fill Cycle                             | 15 sec. after activation.  |
| Harvest Cycle                          | If engaged 15 sec. or longer, at the end of harvest cycle.   |
| Freeze Cycle                           | 15 sec. after activation if activated at least 15 sec. before the 5-min. short cycle protection timer terminates. Otherwise, at the end of the next harvest cycle. |

|                         |                                    |  |                                     |
|-------------------------|------------------------------------|--|-------------------------------------|
| <b>Ice Level in Bin</b> | <b>K Control Board (2A8242-02)</b> |  | <b>K+ Control Board (2A9678-01)</b> |
|                         | <b>K Control Board (2A8242-02)</b> | <b>Remote Ultrasonic Control Board (4A6838-01)</b> |                                     |
|                         | <b>"BC OPEN/CLOSED" LED</b>        | <b>LED 1</b>                                       | <b>"BIN CLS" LED</b>                |
| Empty                   | OFF                                | ON   | OFF                                 |
| Full                    | ON                                 | OFF  | ON                                  |

5a) **K Control Board (2A8242-02) - Bin Full Diagnosis:** Place an object 5" to 7" (127 to 178 mm) away from the UBC sensor lens. If shut down cycle does not start, confirm UBC control board green "LED 1" LED turns off. If not, check for 4VDC at CB K4 pin #1 (R) to CB K4 pin #2 (BK). If 1VDC is present, confirm object placement. If object placement is correct, replace UBC sensor and UBC control board. If UBC control board green "LED 1" LED turns off and CB yellow "BC OPEN/CLOSED" LED does not turn on and 4VDC is present at CB K4 pin #1 (R) to CB K4 pin #2 (BK), replace CB. If CB yellow "BC OPEN/CLOSED" LED turns on and shut down cycle does not start, see "II.B.1.4) 1-min. Fill Cycle."

| <b>Control Board K4 Bin Control Connector</b> |                   |            |
|---|-------------------|------------|
| <b>Bin Full (open)</b>                        |                   |            |
| <b>Pin #</b>                                  | <b>Wire Color</b> | <b>VDC</b> |
| #1 to #2                                      | R to BK           | 4VDC       |
| #1 to #3                                      | R to W            | 1VDC       |
| #2 to #3                                      | BK to W           | 5VDC       |

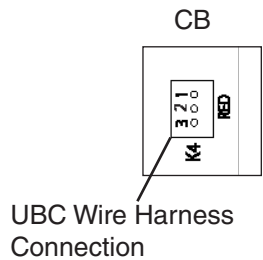

5b) **K+ Control Board (2A9678-01) - Bin Full Diagnosis:** Place an object 5" to 7" (127 to 178 mm) away from the UBC lens. See Fig. 7b. If shut down cycle does not start, confirm CB "BIN CLS" LED turns on. If not, confirm object placement. If object placement is correct, replace UBC sensor and CB. If CB yellow "BIN CLS" LED turns on and shut down cycle does not start, see "II.B.1.4) 1-min. Fill Cycle."

Note: In some cases, removing the UBC sensor and rotating UBC lens up and down, provides better access when troubleshooting.

- 6) Once the icemaker restarts, move the control switch to the "OFF" position, then turn off the power supply.
- 7) Replace the base cover and right side panel in their correct positions.
- 8) Move the control switch to the "ON" position. Replace the front panel in its correct position, then turn on the power supply to start the automatic icemaking process.

Legend: **CB**—control board; **UBC**—ultrasonic bin control

## 2. Bin Control Adjustment

### ⚠ WARNING

- All parts are factory-adjusted. Improper adjustments may adversely affect safety, performance, component life, and warranty coverage.
- In Hoshizaki DB and DM dispenser applications, the bin control controller setting must be adjusted to 2. For Coca-Cola Freestyle® Dispenser and non-Hoshizaki dispenser applications, the bin control controller setting must be adjusted to 3. Increasing the ice level on any dispenser application could lead to icemaker movement, water leakage, or ice overflow.

### NOTICE

- Do not block the bin control lens with top kits or the icemaker will not operate properly.
- Failure to properly adjust the bin control setting could result in water leakage, ice backup, and icemaker damage.

The bin control is factory set to 1 for use on Hoshizaki America standard ice storage bins. See the table below for adjustments to ice level.

**WARNING! Do not adjust outside of these settings.**

- 1) If not already removed, remove the front, top, and right side panels.
- 2) Confirm bin control controller setting for proper application. See the table below for settings. See Fig. 8 for ice level reference.

| Application  | Bin Control Ice Level Settings |  |
|--|--------------------------------|--|
|  | Bin Control Controller Setting | Ice Detection Distance From Bin Control Lens |
| <b>Default: Standard Ice Storage Bins</b>                          | 1                              | 254 mm (10")                                 |
| <b>Hoshizaki DB and DM Dispensers</b>                              | 2                              | 305 mm (12")                                 |
| <b>Coca-Cola Freestyle® Dispenser and Non-Hoshizaki Dispensers</b> | 3                              | 406 mm (16")                                 |
| <b>Optional Settings</b>   | 4                              | 508 mm (20")                                 |
|  | 5                              | 610 mm (24")                                 |

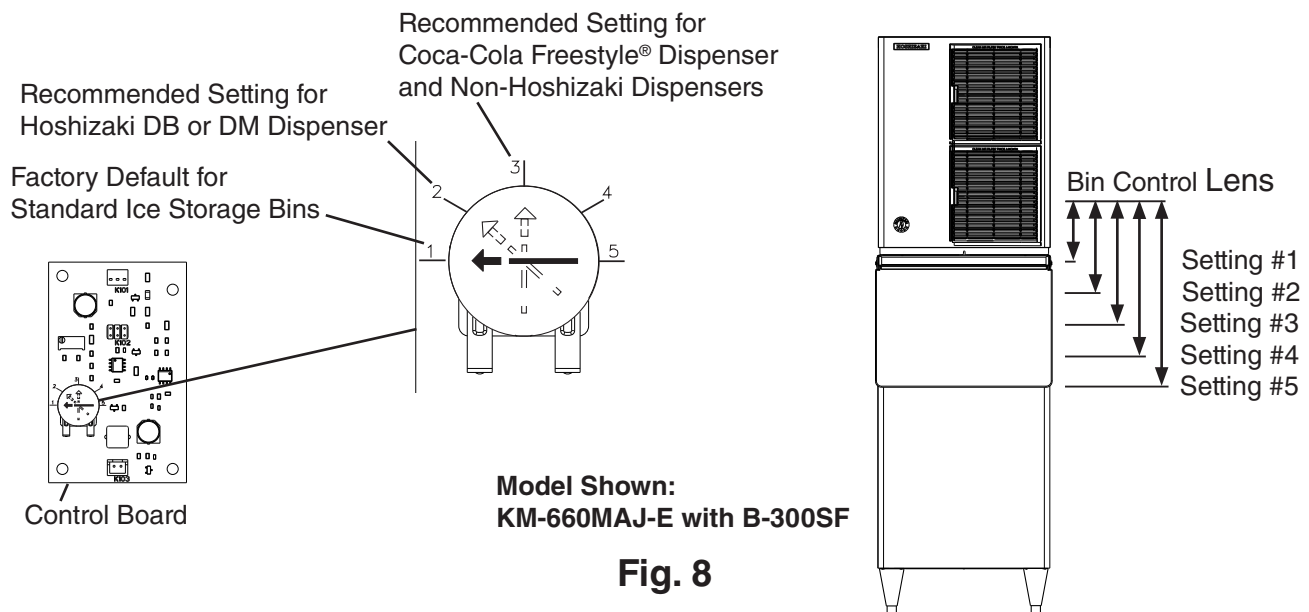

**Fig. 8**

## E. Float Switch Check and Cleaning

FS is used to determine that there is sufficient water in the water tank after the 1-min. fill cycle and after each harvest cycle. FS is also used to determine that the appropriate volume of water has been converted into ice before switching out of the freeze cycle. No adjustment is required.

### 1. Float Switch Check

To check FS, follow the steps below.

- 1) Turn off the power supply.
- 2) Remove the front panel, then move the control switch to the "OFF" position.
- 3) Drain the water tank. Remove the base cover, then disconnect the water tank end of the pump tubing to drain the water tank. See Fig. 9. After the water tank has drained, reconnect the pump tubing.
- 4) Remove the top and right side panels.
- 5) Disconnect the FS connector from CB K5 connector.
- 6) Check for continuity across FS leads. With the water tank empty, FS should be open. If open, continue to step 7. If closed, follow the steps in "II.E.2. Float Switch Cleaning." After cleaning FS, check it again. Replace if necessary.
- 7) Reconnect FS connector to CB K5 connector, then replace the right side and top panels and the base cover in their correct positions.
- 8) Move the control switch to the "ICE" position. Replace the front panel in its correct position, then turn on the power supply. After 1 min., the 1-min. fill cycle should end and the initial harvest cycle should begin. If the initial harvest cycle begins, FS is good and the check is complete. If the initial harvest cycle does not begin, continue to step 9.
- 9) Turn off the power supply.
- 10) Remove the front panel. Move the control switch to the "OFF" position.
- 11) Remove the top and right side panels.
- 12) Disconnect FS connector from CB K5 connector.
- 13) Check for continuity across FS leads. With the water tank full, FS should be closed. If FS is closed and the icemaker will not switch from the 1-min. fill cycle to the initial harvest cycle, replace CB. If FS is open, confirm that the water tank is full. If the water tank is not full, check the water supply, water filters, and inlet water valve. If the water tank is full, follow the steps in "II.E.2. Float Switch Cleaning." After cleaning FS, check it again. Replace if necessary.
- 14) Replace cube guide and base cover (if applicable) in their correct positions.
- 15) Replace the right side and top panels in their correct positions.
- 16) Move the control switch to the "ICE" position, then replace the front panel in its correct position. Turn on the power supply to start the automatic icemaking process.

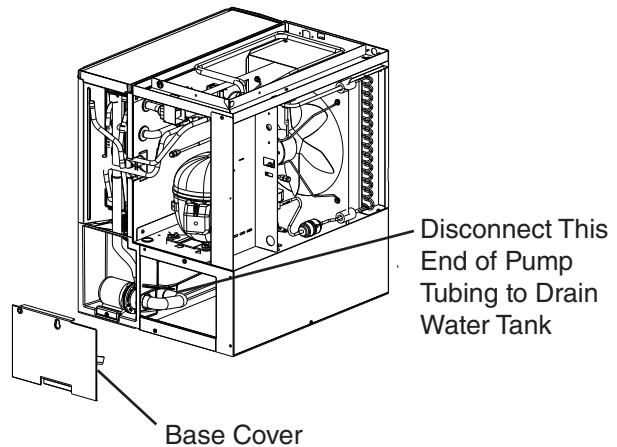

**Fig. 9**

Legend: **CB**—control board; **FS**—float switch



## 2. Float Switch Cleaning

Depending on local water conditions, scale may build up on FS. Scale on the switch can cause the float to stick. In this case, FS should be cleaned.

- 1) Turn off the power supply.
- 2) Remove the front panel, then move the control switch to the "OFF" position.
- 3) Remove the base cover, disconnect the water tank end of the pump tubing to drain the water tank. See Fig. 5. After the water tank has drained, reconnect the pump tubing.
- 4) Remove the cube guide, then pull the tab on the float switch bracket to release the float switch assembly from the water tank.
- 5) Remove the spring retainer clip from the float switch rod, then remove the float. Be careful not to bend the spring retainer clip excessively when removing it. See Fig. 10.
- 6) Wipe down the float switch bracket assembly, stem, and float with a mixture of 1 part Hoshizaki "Scale Away" and 25 parts warm water. Rinse the parts thoroughly with clean water. **WARNING! Do not remove the lock nut on the float switch assembly. This is factory sealed and must not be removed.**
- 7) Reassemble the float switch assembly and replace it in its correct position.
- 8) Move the control switch to the "ICE" position.
- 9) Replace the base cover, cube guide, and front panel in their correct positions.
- 10) Turn on the power supply to start the automatic icemaking process.

Legend: **CB**—control board; **FS**—float switch

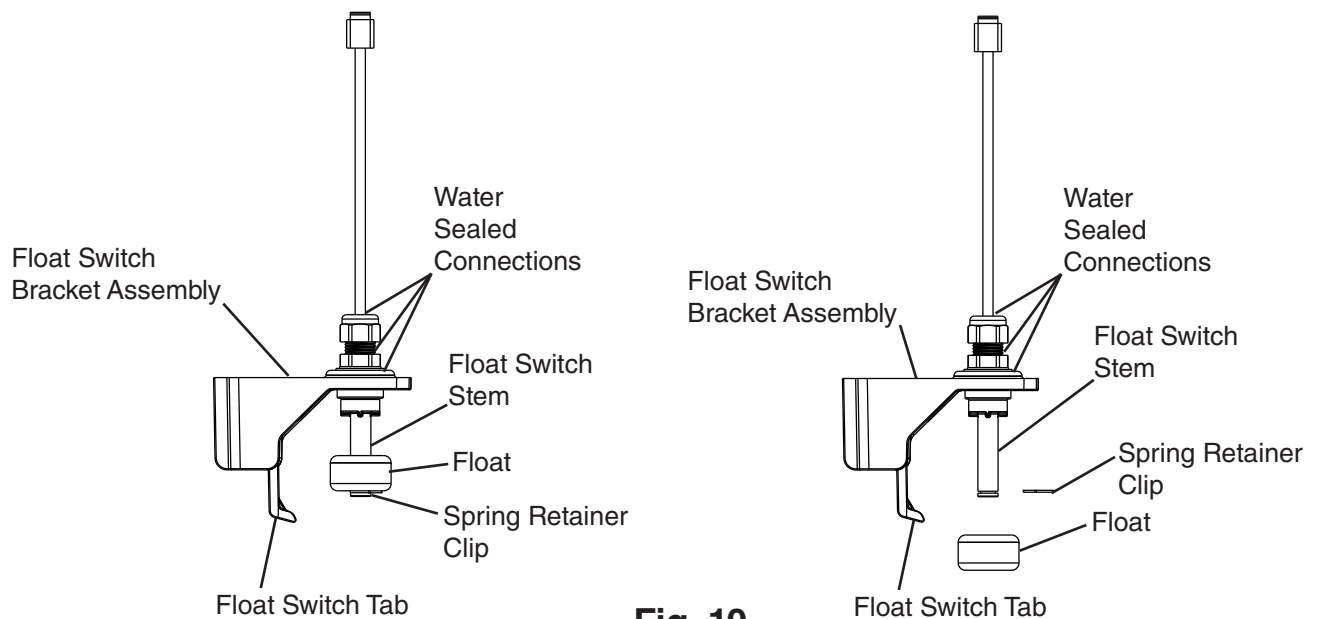

**Fig. 10**

## F. Thermistor Check

To check thermistor resistance, follow the steps below.

- 1) Turn off the power supply.
- 2) Remove the front panel. Move the control switch to the "OFF" position, then remove the top and right side panels.
- 3) Remove the thermistor from the refrigerant tubing.
- 4) Immerse the thermistor sensor portion in a glass containing ice and water for 2 or 3 min.
- 5) Disconnect the thermistor connector from CB K3 connector and check the resistance between thermistor leads. Normal range is 4.7 to 6.2 k $\Omega$ . If outside the normal range, replace the thermistor. See "IV.B. Component Service Information." If within the normal range, continue to the next step.
- 6) Replace the thermistor in its correct position. See "IV.B. Component Service Information."
- 7) Reconnect the thermistor connector to CB K3 connector.
- 8) Replace the right side and top panels in their correct positions.
- 9) Move the control switch to the "ICE" position.
- 10) Replace the front panel in its correct position.
- 11) Turn on the power supply.
- 12) Once the harvest cycle starts (Comp energizes), begin timing the harvest cycle.
- 13) The harvest timer and harvest cycle should terminate within 2 to 5 min. If the harvest cycle does not terminate within 2 to 5 min., replace CB.

Legend: **CB**—control board; **Comp**—compressor

## G. Control Switch

The control switch has two positions: "ON for power on, "PUMP" to energize the pump motor and circulate the water in the water tank.

## H. Mode Switch

The mode switch has two positions: "ICE" for icemaking cycle, "CLEAN" for initiating the cleaning and sanitizing program.



# I. Diagnostic Tables

## 1. No Ice Production

| No Ice Production - Possible Cause                              |   |
|---|---|
| 1. Power Supply   | a) Off, blown fuse, or tripped breaker.                                   |
|   | b) Not within specifications.   |
| 2. Fuse (Power Supply Cord or Control Box)                      | a) Blown.   |
| 3. Control Switch   | a) In "OFF" or "PUMP" position.   |
|   | b) Defective.   |
| 4. Main Transformer   | a) Defective.   |
| 5. High-Pressure Switch   | a) Dirty condenser.   |
|   | b) Fan motor not operating.   |
|   | c) Refrigerant overcharged.   |
|   | d) Bad contacts.  |
|   | e) Refrigerant lines or components plugged.                               |
| 6. Control Transformer (115VAC/10.5VAC)                         | a) Coil winding open or shorted.  |
| 7. Control Board<br>See "II.C. Control Board Check"             | a) In alarm.  |
|   | b) K Control Board CB yellow "BC OPEN/CLOSED" LED on (bin full).          |
|   | b) K+ Control Board CB yellow "BIN CLS" LED on (bin full).                |
| 8. Ultrasonic Bin Control<br>See "II.D.1. Bin Control Check"    | c) Defective.   |
|   | a) Tripped with bin filled with ice.                                      |
|   | b) Sensor lens dirty.   |
| 9. Mode Switch  | c) Defective.   |
|   | a) In "CLEAN" position.   |
| 10. Water Supply  | b) Defective.   |
|   | a) Water supply off or improper water pressure.                           |
| 11. Inlet Water Valve   | b) External water filters clogged.  |
|   | a) Screen or orifice clogged.   |
|   | b) Coil winding open.   |
| 12. Float Switch<br>See "II.E. Float Switch Check and Cleaning" | c) Water valve open in freeze cycle.                                      |
|   | a) Float does not move freely.  |
| 13. Compressor  | b) Defective.   |
|   | a) Compressor relay/magnetic contactor contacts bad or coil winding open. |
|   | b) Start capacitor or run capacitor defective (single phase).             |
|   | c) Internal protector open.   |
|   | d) Start relay contacts bad or coil winding open (single phase).          |
| 14. Hot Gas Valve   | e) Compressor defective.  |
|   | a) Closed in harvest cycle.   |
| 15. Thermistor<br>See "II.F. Thermistor Check"                  | b) Open in freeze cycle.  |
|   | a) Loose, disconnected, or defective.                                     |

| <b>No Ice Production - Possible Cause</b> |   |
|---|---|
| 16. Pump Motor                            | a) Motor winding open.                    |
|   | b) Bearing worn out or locked rotor.      |
|   | c) Defective capacitor.                   |
|   | d) Mechanical seal worn out.              |
| 17. Thermostatic Expansion Valve          | a) Bulb loose.                            |
|   | b) Operating erratically.                 |
| 18. Liquid Line Valve                     | a) Closed in freeze cycle.                |
|   | b) Open in harvest cycle.                 |
| 19. Fan Motor                             | a) Motor winding open.                    |
|   | b) Bearing worn out or locked rotor.      |
|   | c) Defective capacitor.                   |
| 20. Water System                          | a) Water leaks causing short freeze time. |

## 2. Freeze-Up

Defrost and clean the icemaker prior to diagnosing freeze-up. Fill out a freeze-up checklist. See "II.J. Freeze Up Check List," the Hoshizaki America Technician's Pocket Guide, or contact your local distributor for a copy of the freeze-up checklist.

| <b>Freeze-Up - Possible Cause</b>   |  |
|---|--|
| <b>Harvest Cycle</b>  |  |
| 1. Evaporator   | a) Scaled up.  |
|   | b) Damaged.  |
| 2. Cube Guides  | a) Out of position.  |
|   | b) Damaged.  |
| 3. Spray Tubes and/or Spray Guides  | a) Dirty.  |
|   | b) Out of position.  |
| 4. Water Supply   | a) Low water pressure.   |
|   | b) External water filters clogged.   |
|   | c) Insufficient water line size.<br>Minimum 1/4" Nominal ID (6 mm Nominal OD in the EU) copper water tubing or equivalent. |
| 5. Inlet Water Valve  | a) Screen or orifice clogged.  |
|   | b) Defective.  |
| 6. Float Switch<br>See "II.E. Float Switch Check and Cleaning"                            | a) Dirty, sticking.  |
|   | b) Defective.  |
| 7. Refrigerant Charge   | a) Low.  |
| 8. Control Board<br>See "III.C. Settings and Adjustments" and "II.C. Control Board Check" | a) Harvest timer (S4 dip switch 1 & 2) set too short.  |
|   | b) Harvest pump timer (S4 dip switch 7) not in factory default position.   |
|   | c) Defective.  |
| 9. Ultrasonic Bin Control<br>See "II.D.1. Bin Control Check"                              | a) Defective.  |

| <b>Freeze-Up - Possible Cause</b>                              |   |
|--|---|
| 10. Thermistor<br>See "II.F. Thermistor Check"                 | a) Loose, disconnected, or defective.                   |
| 11. Thermostatic Expansion Valve                               | a) Defective.   |
| 12. Hot Gas Valve  | a) Defective.   |
| 13. Liquid Line Valve  | a) Defective.   |
| <b>Freeze Cycle</b>  |   |
| 1. Evaporator  | a) Scaled up.   |
|  | b) Damaged.   |
| 2. Spray Tubes and/or Spray Guides                             | a) Dirty.   |
|  | b) Out of position.                                     |
| 3. Refrigerant Charge  | a) Low.   |
| 4. Control Board<br>See "II.C. Control Board Check"            | a) Freeze timer (S4 dip switch 9 & 10) set incorrectly. |
|  | b) Defective.   |
| 5. Inlet Water Valve   | a) Leaking by.  |
| 6. Float Switch<br>See "II.E. Float Switch Check and Cleaning" | a) Float does not move freely.                          |
|  | b) Defective.   |
| 7. Pump Motor  | a) RPM too slow.  |
|  | b) Impeller damaged.                                    |
| 8. Thermostatic Expansion Valve                                | a) Bulb loose or defective.                             |
| 9. Liquid Line Valve   | a) Restricted.  |

### 3. Low Ice Production

| <b>Low Ice Production - Possible Cause</b>          |   |
|---|---|
| <b>Long Harvest Cycle</b>                           |   |
| 1. Evaporator                                       | a) Scaled up.   |
| 2. Spray Tubes and/or Spray Guides                  | a) Dirty.   |
|   | b) Out of position.   |
| 3. Refrigerant Charge                               | a) Low.   |
| 4. Water Supply                                     | a) Low water pressure.  |
|   | b) External water filters clogged.  |
|   | c) Insufficient water line size.<br>Minimum 1/4" Nominal ID (6 mm Nominal OD in the EU) water tubing or equivalent. |
|   | d) Too cold.  |
| 5. Control Board<br>See "II.C. Control Board Check" | a) Thermistor connection loose (K3).  |
|   | b) Defective.   |
| 6. Thermistor<br>See "II.F. Thermistor Check"       | a) Loose, disconnected, or defective.   |
| 7. Hot Gas Valve                                    | a) Erratic or closed.   |
| 8. Inlet Water Valve                                | a) Screen or orifice clogged.   |
| 9. Compressor                                       | a) Inefficient or off.  |
| 10. Liquid Line Valve                               | a) Erratic or open.   |
| 11. Thermostatic Expansion Valve                    | a) Defective.   |

| <b>Low Ice Production - Possible Cause</b>                     |  |
|--|--|
| <b>Long Freeze Cycle</b>                                       |  |
| 1. Evaporator  | a) Scaled up, dirty.                   |
| 2. Float Switch<br>See "II.E. Float Switch Check and Cleaning" | a) Scaled up, dirty.                   |
|  | b) Float sticking.                     |
|  | c) Defective switch.                   |
| 3. Inlet Water Valve   | a) Leaking by.                         |
| 4. Hot Gas Valve   | a) Erratic or open.                    |
| 5. Condenser   | a) Clogged.                            |
| 6. Control Board<br>See "II.C. Control Board Check"            | a) Float switch connection loose (K5). |
|  | b) Defective.                          |
| 7. Refrigerant Charge  | a) Low.                                |
| 8. Thermostatic Expansion Valve                                | a) Bulb loose.                         |
|  | b) Defective.                          |
| 9. Compressor  | a) Inefficient or off.                 |
| 10. Pump Motor   | a) RPM too slow.                       |
| 11. Liquid Line Valve  | a) Erratic or restricted.              |
| 12. Splash Guard   | a) Out of place.                       |
|  | b) Missing or damaged.                 |

# J. Freeze-Up Check List

## Freeze-Up Check List

**Please Complete When Diagnosing a Freeze-Up, Refrigerant Leak, or Low Charge**  
 Technical Support Fax #: 770-487-3360  
 Make Copies And Use As Needed

**Model #** \_\_\_\_\_ **Serial #** \_\_\_\_\_ **Install Date** \_\_\_\_\_ **Freeze-Up Date** \_\_\_\_\_

List model and manufacture of bin or dispenser \_\_\_\_\_.

Date appliance was last cleaned: \_\_\_\_\_.

### Freeze-Up Defrost

YES NO

- [ ] [ ] 1) After defrosting, was the appliance leak checked?  
 [ ] [ ] 2) Were any leaks found?  
 If so where? \_\_\_\_\_.  
 [ ] [ ] 3) Was any refrigerant added to the unit?  
 If so, how much? \_\_\_\_\_.

### Set Up

- [ ] [ ] 4) Is the appliance stand alone?  
 [ ] [ ] 5) Is water line independent?  
 [ ] [ ] 6) Is water line correct size? If not \_\_\_\_\_,"  
 3/8" Nominal ID Copper Water Tubing or  
 Equivalent.  
 7) What is water pressure? \_\_\_\_\_.  
 Water Temperature \_\_\_\_\_.  
 [ ] [ ] 8) Does appliance have any water filtration?  
 If yes please list the following:  
 Filter brand \_\_\_\_\_.  
 Model \_\_\_\_\_.  
 Filter pressure gauge reading during the fill  
 cycle \_\_\_\_\_.  
 Date filter was last  
 replaced? \_\_\_\_\_.  
 GPM or LPM flow rate of filter  
 system? \_\_\_\_\_.  
 9) Ambient temperature at appliance?  
 \_\_\_\_\_.  
 At remote condenser (if applicable)? \_\_\_\_\_.

### Appliance Status

- [ ] [ ] 10) Is the appliance and/or float switch dirty?  
 11) List the S4 (1-10) and S5 (1-5) DIP switch  
 settings.  
 S4: 1 \_\_\_ 2 \_\_\_ 3 \_\_\_ 4 \_\_\_ 5 \_\_\_ 6 \_\_\_ 7 \_\_\_ 8 \_\_\_ 9 \_\_\_ 10 \_\_\_  
 S5: 1 \_\_\_ 2 \_\_\_ 3 \_\_\_ 4 \_\_\_ 5 \_\_\_  
 [ ] [ ] 12) Is DIP switch number 7 ON (harvest pump time  
 (harvest assist)) all models?  
 [ ] [ ] 13) Is the cube guide positioned correctly?  
 [ ] [ ] 14) Are the evaporator separators positioned  
 properly?  
 [ ] [ ] 15) Is the thermistor properly mounted, tight, and  
 insulated?  
 [ ] [ ] 16) Is the TXV bulb properly mounted, tight, and  
 insulated?  
 [ ] [ ] 17) Are splash guards in place (if applicable)?

### Appliance Sequence of Operation

#### Fill

YES NO

- [ ] [ ] 18) Does the water tank fill and overflow?  
 60-90 sec. Note: Larger models may take up to  
 120 seconds to overflow when empty.  
 [ ] [ ] 19) If NO in step 17, is water flow 5GPM for larger?

#### Harvest

- [ ] [ ] 20) Is the hot gas valve opening?  
 [ ] [ ] 21) Is harvest pump time (harvest assist) utilized  
 (S4 dip switch 7)?  
 [ ] [ ] 22) Is hot gas valve opening in harvest?  
 [ ] [ ] 23) Does water valve close completely when  
 deenergized?  
 24) What was length of harvest? \_\_\_\_\_.

#### Freeze

- [ ] [ ] 25) Is pump motor energized in freeze cycle except  
 during 10-sec. anti-slush. If activated (S5 dip  
 switch 5 on)?  
 26) Water-cooled condenser outlet temperature  
 5-min. into freeze? \_\_\_\_\_°F.  
 27) What was length of freeze? \_\_\_\_\_.  
 [ ] [ ] 28) Is the cube size consistent from inlet to outlet of  
 evaporator?  
 [ ] [ ] 29) Is ice still dropping when next freeze cycle starts?  
 30) What is the ice drop weight? \_\_\_\_\_.  
 31) What is head pressure?  
 Freeze \_\_\_\_\_ Harvest \_\_\_\_\_.  
 (Freeze pressure should be taken 5 minutes into  
 the freeze cycle).  
 32) What is suction pressure?  
 Freeze \_\_\_\_\_ Harvest \_\_\_\_\_.  
 (Freeze pressure should be taken 5 minutes into  
 the freeze cycle).  
 [ ] [ ] 33) When activating bin control, did appliance  
 shutdown within 15 seconds in the first 5 minutes  
 of freeze cycle?

Note: Make copies of this form and use it when diagnosing a freeze up condition. Submit a completed copy of the checklist along with the freeze-up labor claim form.

---

### III. Controls and Adjustments

- A Hoshizaki exclusive control board is employed in KM series appliances.
- All models are pretested and factory adjusted.
- For a control board check procedure, see "II.C. Control Board Check."

| <b><i>NOTICE</i></b>   |
|--|
| <ul style="list-style-type: none"><li>• Fragile, handle very carefully.</li><li>• The control board contains integrated circuits, which are susceptible to failure due to static discharge. It is especially important to touch the metal part of the icemaker when handling or replacing the control board.</li><li>• Do not touch the electronic devices on the control board or the back of the control board.</li><li>• Do not change wiring and connections. Do not misconnect K3 WHITE, K4 RED, and K5 BLACK, because the same connector is used for the thermistor, bin control, and float switch.</li><li>• Do not short out power supply to test for voltage.</li><li>• Always replace the whole control board assembly if it goes bad.</li></ul> |

# A. Control Board Layout

## 1. K Control Board (2A8242-02)

### K Control Board

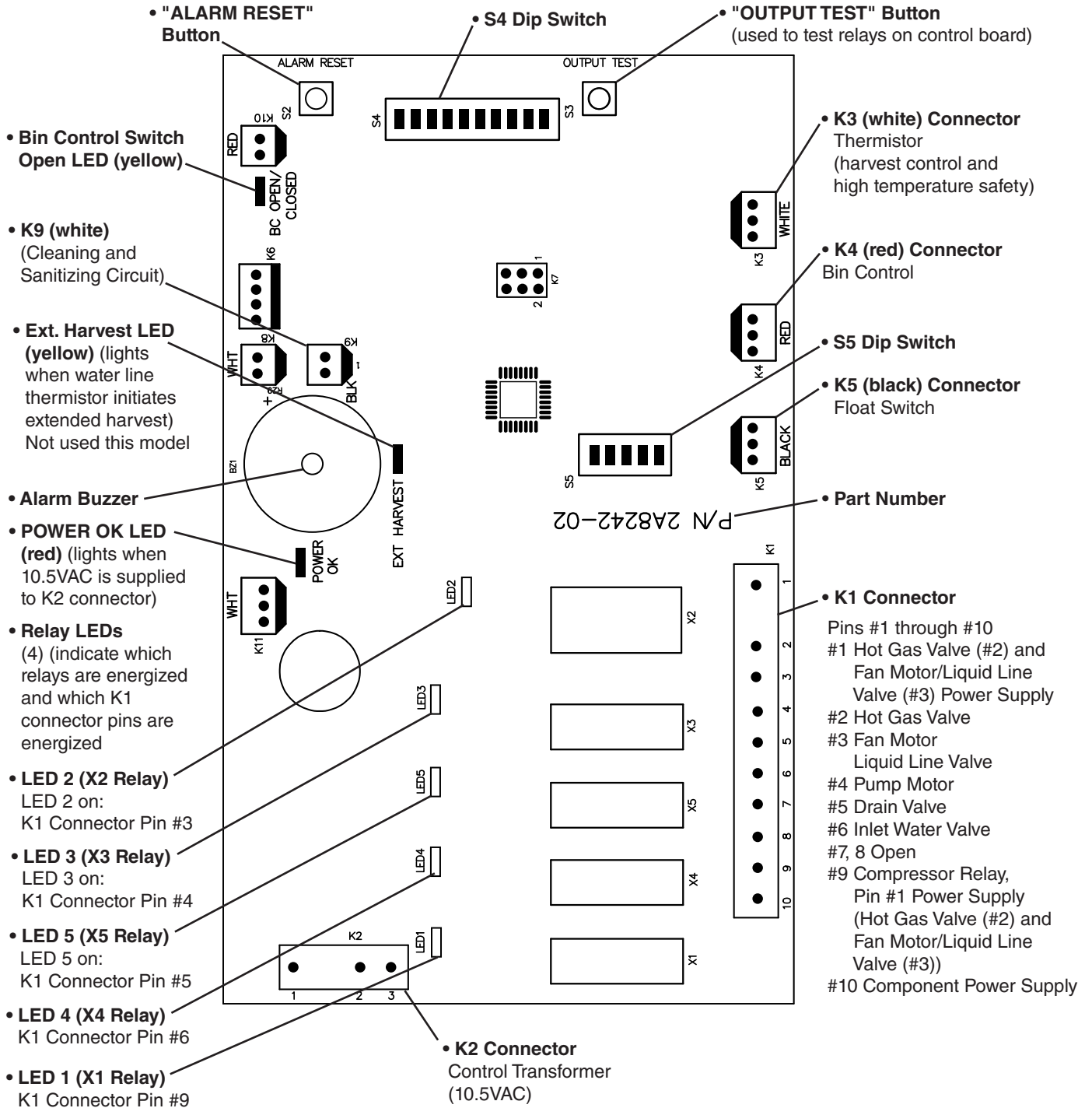

| K Control Board |           |
|-----------------|-----------|
| Part Number     | 2A8242-02 |

## 2. K+ Control Board (2A9678-01)

### K+ Control Board

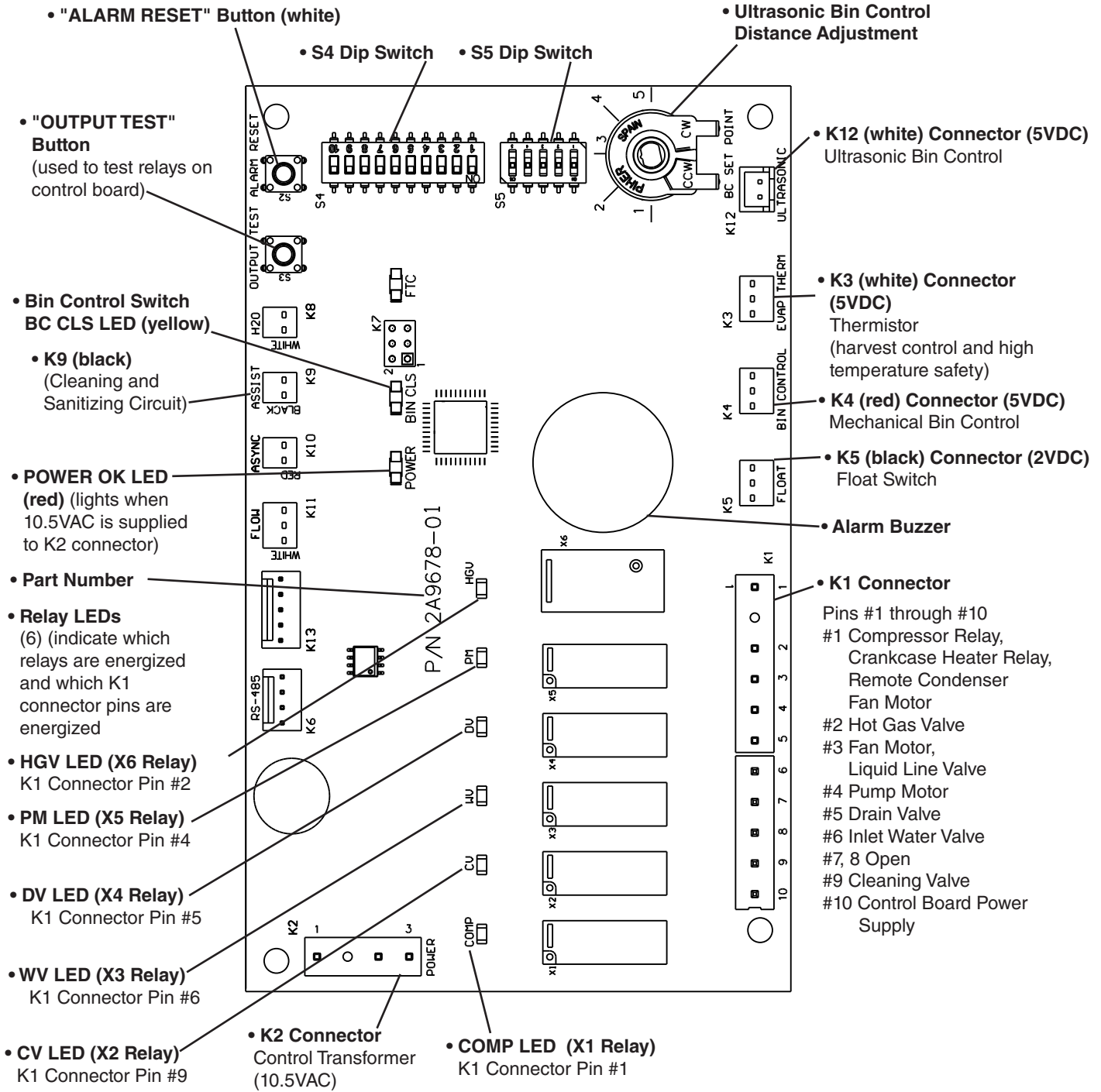

| K+ Control Board |           |
|------------------|-----------|
| Part Number      | 2A9678-01 |



## B. LED Lights and Audible Alarm Safeties

### 1. K Control Board (2A8242-02)

Beep occurs and red CB "POWER OK" LED turns on when control switch is moved to "ICE" position.

#### Sequence

Green LEDs 1 through 5 turn on and sequence from initial startup as listed in the table below. Order of green LEDs from the outer edge of control board is 1, 4, 5, 3, 2.

| Sequence Step                      | LED        | Energized Components   | Time LEDs are On                             |                      |
|------------------------------------|------------|------------------------|--|----------------------|
|                                    |            |                        | Min.   | Max.                 |
| 1-Minute Fill Cycle                | 4          | WV                     |  |                      |
| Harvest Cycle                      | 1, 4       | Comp, HGV, WV          | 1 minute                                     | 20 minutes           |
| Harvest Pump Time (harvest assist) | 1, 3       | Comp, HGV, PM          | 0 seconds                                    | 50 seconds           |
| Freeze Cycle                       | 1, 2, 3    | Comp, FM, PM, LLV      | 5 minutes                                    | freeze timer setting |
| Anti-Slush Control                 | 1, 2       | Comp, FM, LLV          | PM off 10 sec. when thermistor at 36°F (2°C) |                      |
| Pump-Out Cycle                     | 1, 4, 5, 3 | Comp, HGV, PM, WV*, DV | 10 seconds                                   | 20 seconds           |
| *pump-out timer setting            |            |                        |  |                      |

#### Alarms

| Type  | Alarm  | Notes   |
|---|--|---|
| 1<br>Beep   | High Evaporator Temp. (temperature > 127°F) (53°C)                   | Check for harvest problem (stuck HGV or relay), hot water entering unit, or shorted thermistor.   |
| 2<br>Beep   | Harvest Backup Timer (harvest > 20 min. for two cycles in a row)     | Check thermistor (open), HGV not opening, TXV or LLV leaking by, low charge, inefficient Comp.  |
| 3<br>Beep   | Freeze Timer (freeze > freeze timer setting for two cycles in a row) | Check FS stuck closed (up), WV leaking by, HGV leaking by, PM not pumping, TXV defective, LLV not opening, low charge, or inefficient Comp. |
| To reset above safeties, press "ALARM RESET" button with power supply on. |  |   |
| 6   | Low Voltage (92Vac±5% or less)                                       | Red LED turns off if voltage protection operates. Control voltage safeties automatically reset when voltage is corrected.                   |
| 7   | High Voltage (147Vac±5% or more)                                     |   |

Legend: **Comp**—compressor; **DV**—drain valve; **FM**—fan motor; **FS**—float switch; **HGV**—hot gas valve; **LLV**—liquid line valve; **PM**—pump motor; **TXV**—thermostatic expansion valve; **WV**—inlet water valve

## 2. K+ Control Board (2A9678-01)

Beep occurs and red CB "POWER OK" LED turns on when control switch is moved to "ICE" position.

### Sequence

Green LEDs turn on and sequence from initial startup as listed in the table below. Order of green LEDs from the outer edge of control board is Comp, CV, WV, DV, PM, FM/HGV.

| Sequence Step   | LED                         | Energized Components        | Time LEDs are On                             |                      |
|---|-----------------------------|-----------------------------|--|----------------------|
|   |                             |                             | Min.   | Max.                 |
| 1-Minute Fill Cycle                                   | WV                          | WV                          |  |                      |
| Harvest Cycle   | Comp, WV, **FM/HGV          | Comp, FMR, HGV, WV          | 1 minute                                     | 20 minutes           |
| Harvest Pump Time (harvest assist)                    | Comp, PM, **FM/HGV          | Comp, FMR, HGV, PM          | 0 seconds                                    | 50 seconds           |
| Freeze Cycle  | Comp, PM                    | Comp, FM/FMR, PM, LLV       | 5 minutes                                    | freeze timer setting |
| Anti-Slush Control                                    | Comp                        | Comp, FM/FMR, LLV           | PM off 10 sec. when thermistor at 36°F (2°C) |                      |
| Pump-Out Cycle  | Comp, PM, **FM/HGV, DV, *WV | Comp, FMR, HGV, PM, *WV, DV | 10 seconds                                   | 20 seconds           |
| *pump-out timer setting **FM is OFF when FM/HGV is ON |                             |                             |  |                      |

### Alarms

| Type  | Alarm  | Notes   |
|---|--|---|
| 1<br>Beep   | High Evaporator Temp. (temperature > 127°F) (53°C)                   | Check for harvest problem (stuck HGV or relay), hot water entering unit, stuck HM, or shorted thermistor.   |
| 2<br>Beep   | Harvest Backup Timer (harvest > 20 min. for two cycles in a row)     | Check thermistor (open), HGV not opening, TXV or LLV leaking by, low charge, inefficient Comp, or WRV leaking by.   |
| 3<br>Beep   | Freeze Timer (freeze > freeze timer setting for two cycles in a row) | Check FS stuck closed (up), WV leaking by, HGV leaking by, PM not pumping, TXV defective, LLV not opening, low charge, HM not bypassing, or inefficient Comp. |
| To reset above safeties, press "ALARM RESET" button with power supply on. |  |   |
| 6   | Low Voltage (92Vac±5% or less)                                       | Red LED turns off if voltage protection operates. Control voltage safeties automatically reset when voltage is corrected.                                     |
| 7   | High Voltage (147Vac±5% or more)                                     |   |

Legend: **Comp**—compressor; **CV**—cleaning valve; **DV**—drain valve; **FM**—fan motor; **FMR**—fan motor remote; **FS**—float switch; **HGV**—hot gas valve; **HM**—headmaster (C.P.R.); **LLV**—liquid line valve; **PM**—pump motor; **TXV**—thermostatic expansion valve; **WRV**—water regulating valve; **WV**—inlet water valve

## C. Settings and Adjustments

### **NOTICE**

Dip switches are factory set. Failure to maintain factory settings may adversely affect performance and warranty coverage. For more information, contact your Hoshizaki Service Center.

#### 1. Default Dip Switch Settings

The dip switches are factory-adjusted to the following positions:

| S4 Dip Switch No. | 1   | 2   | 3   | 4   | 5   | 6   | 7  | 8   | 9  | 10 |
|-------------------|-----|-----|-----|-----|-----|-----|----|-----|----|----|
| KM-520MAJ-E       | ON  | ON  | OFF | OFF | ON  | OFF | ON | OFF | ON | ON |
| KM-660MAJ-E       | OFF | OFF | OFF | OFF | OFF | OFF | ON | OFF | ON | ON |

| S5 Dip Switch (Do Not Adjust) |     |     |     |     |    |
|-------------------------------|-----|-----|-----|-----|----|
| Dip Switch No.                | 1   | 2   | 3   | 4   | 5  |
| All Models                    | OFF | OFF | OFF | OFF | ON |

#### **S4 Dip Switch**

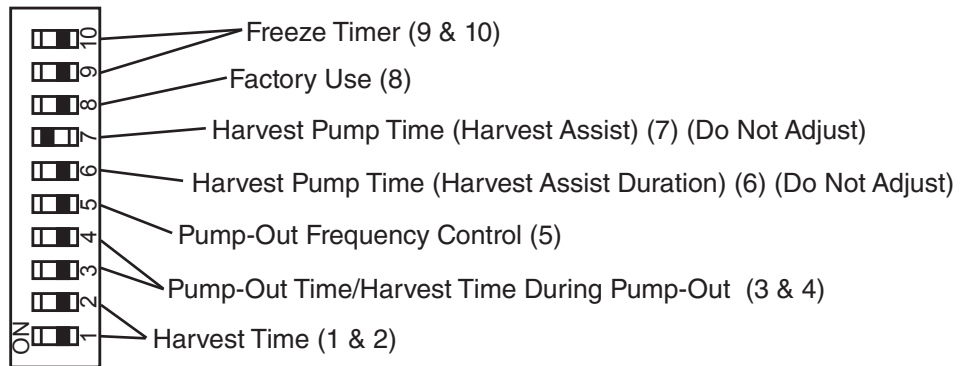

#### **S5 Dip Switch**

(Do Not Adjust)

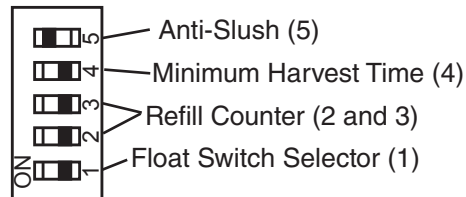

## 2. Harvest Time (S4 dip switch 1 & 2)

The harvest timer starts counting when the thermistor reaches 48°F (9°C) at the evaporator outlet and the control board reads 3.9 kΩ from the thermistor. The harvest timer is factory set, and generally no adjustment is required. However, a setting longer than the factory setting may be advised in cases where the drain provided at harvest needs to be prolonged for extra cleaning. Note that the pump-out timer (S4 dip switch 3 & 4) acts in place of the harvest timer during cycles with a pump out.

For details, see "III.C.3. Pump-Out Timer (S4 dip switch 3 & 4)."

Note: On models with a pump-out every cycle, the harvest timer is only relevant during the initial harvest cycle since a pump out occurs every cycle thereafter.

| S4 Dip Switch Setting |       | Time (sec.) |         |
|-----------------------|-------|-------------|---------|
| No. 1                 | No. 2 | S5-4 OFF    | S5-4 ON |
| OFF                   | OFF   | 60          | 30      |
| ON                    | OFF   | 90          | 45      |
| OFF                   | ON    | 120         | 60      |
| ON                    | ON    | 180         | 75      |

## 3. Pump-Out Time/Harvest Time During Pump-Out (S4 dip switch 3 & 4)

When a pump-out is called for, the pump motor stops for 2 sec. After 2 sec. the drain valve and pump motor energize. Water is removed from the bottom of the water tank and sent down the drain. The pump-out drains the water tank for the time determined by the pump-out timer. The pump-out timer also acts in place of the harvest timer during cycles with a pump-out. The pump-out timer is factory set, and generally no adjustment is required. However, where water quality is bad and the icemaker needs a longer pump-out time, the pump-out timer can be adjusted. The pump-out timer control can be set to pump-out for 10 or 20 sec. During pump-out cycles minimum harvest time is based on times given in the table below.

| S4 Dip Switch Setting |       | Time (sec.) |          |         | Inlet Water Valve |         |
|-----------------------|-------|-------------|----------|---------|-------------------|---------|
| No. 3                 | No. 4 | T1          | T2       |         | S5-4 OFF          | S5-4 ON |
|                       |       |             | S5-4 OFF | S5-4 ON |                   |         |
| OFF                   | OFF   | 10          | 150      | 100     | Closed            | Closed  |
| ON                    | OFF   | 10          | 180      | 130     | Closed            | Closed  |
| OFF                   | ON    | 10          | 120      | 70      | Open              | Closed  |
| ON                    | ON    | 20          | 180      | 180     | Closed            | Closed  |

T1: Time to drain the water tank

T2: Harvest timer at pump out

#### 4. Pump-Out Frequency Control (S4 dip switch 5)

The pump-out frequency control is factory set to drain the water tank every 10 cycles. Generally no adjustment is required. However, where water quality is bad and the icemaker needs a pump-out more often, the pump-out frequency can be adjusted. The pump-out frequency control can be set to have a pump-out occur every cycle, or every 10 cycles.

The first pump-out is dependent on S4 dip switch 5. See the table below.

| S4 Dip Switch Setting | Pump-Out Frequency | 1st Pump-Out            |
|-----------------------|--------------------|-------------------------|
| No. 5                 |                    |                         |
| OFF                   | Every 10 cycles    | After 11th freeze cycle |
| ON                    | Every cycle        | After 2nd freeze cycle  |

#### 5. Harvest Pump Time (Harvest Assist Duration) (S4 dip switch 6)

##### **NOTICE**

Factory set for proper operation. Do not adjust. Adjustment outside of the factory default setting may result in damage to the appliance.

Harvest pump time (harvest assist duration) is only active when S4 dip switch 7 is in the "ON" position. In the factory default position, the harvest pump time (harvest assist) starts with 50 sec. left to go in harvest cycle (S4 dip switch 6) and after the thermistor reaches 48°F (9°C) at the evaporator outlet and the control board reads 3.9 kΩ from the thermistor. The harvest pump time (harvest assist duration) is factory set, and no adjustment is required.

| S4 Dip Switch Setting | Harvest Pump Time<br>(Harvest Assist Duration) |         |
|-----------------------|--|---------|
|                       | S5-4 OFF                                       | S5-4 ON |
| No. 6                 |  |         |
| OFF                   | 50 sec.  | 25 sec. |
| ON                    | 25 sec.  | 15 sec. |

## 6. Harvest Pump Time (Harvest Assist) (S4 dip switch 7)

### **NOTICE**

Factory set for proper operation. Do not adjust. Adjustment outside of the factory default setting may result in damage to the appliance.

Depending on S4 dip switch 7 setting, the pump motor either stays off or is energized during the last seconds of the harvest cycle. When the pump motor is energized (S4 dip switch 7 on), water circulates over the evaporator. The harvest water valve is open during harvest for a maximum of 6 minutes or the length of harvest minus the harvest pump time value(S4 dip switch 6), whichever is shorter.

When S4 dip switch 7 is in the on position and harvest begins, 50 sec. before harvest termination, LED 4 turns off, inlet water valve Next, LED 3 turns on and control board K1 connector pin #4 (R) energizes, energizing the pump motor for the last seconds of harvest. Harvest pump time adjusted by S4 dip switch 1 & 2 and S5 dip switch 4 settings. Contact Technical Support before adjusted these settings.

| S4 Dip Switch Setting |  | Harvest Pump Time (sec.) (Harvest Assist) |
|-----------------------|--|---|
| No. 7                 |  |   |
| OFF                   |  | 0   |
| ON                    |  | 50  |

## 7. Factory Use (S4 dip switch 8)

Factory set for proper operation. Do not adjust. This must be left in the factory default position.

## 8. Freeze Timer (S4 dip switch 9 & 10)

### **NOTICE**

Adjust to proper specification, or the icemaker may not operate correctly.

The freeze timer setting determines the maximum allowed freeze time to prevent possible freeze-up issues. Upon termination of the freeze timer, the control board initiates the harvest cycle or pump-out cycle. After 2 consecutive freeze timer terminations, the control board shuts down the icemaker. In this case, see "II.1.3. Low Ice Production" for possible solutions. The freeze timer is factory set and no adjustment is required. Before changing this setting, contact Hoshizaki Technical Support at 1-800-233-1940 for recommendations.

| S4 Dip Switch Setting |        | Time (min.) |
|-----------------------|--------|-------------|
| No. 9                 | No. 10 |             |
| OFF                   | OFF    | 60          |
| OFF                   | ON     | 50          |
| ON                    | OFF    | 70          |
| ON                    | ON     | 75          |

## 9. Pump-Out Pump Motor Direction (S5 dip switch 1)

### **NOTICE**

Do not adjust. This must be left in the factory default position or the icemaker will not operate correctly.

The pump-out pump motor direction setting determines pump motor rotation during pump-out. On models with a drain valve pump motor rotation doesn't change at pump-out. Pump motor rotates in forward direction and drain valve is energized for pump-out. On models with a check valve, pump motor rotation reverses at pump-out. Pump motor rotates in reverse direction and opens check valve for pump-out.

| <b>S5 Dip Switch Setting</b> |   |
|------------------------------|---|
| <b>No. 1</b>                 | <b>Pump-Out Components</b>                  |
| OFF                          | Pump Motor Forward Rotation and Drain Valve |
| ON                           | Pump Motor Reverse Rotation and Check Valve |

## 10. Refill Counter (S5 dip switch 2 and 3)

### **NOTICE**

Do not adjust. These must be left in the factory default position or the icemaker will not operate correctly.

| <b>S5 Dip Switch Setting</b> |              | <b>Refill Counter</b> |
|------------------------------|--------------|-----------------------|
| <b>No. 2</b>                 | <b>No. 3</b> |                       |
| OFF                          | OFF          | 0                     |
| OFF                          | ON           | 1 refill              |
| ON                           | OFF          | 9 refills             |
| ON                           | ON           | 10 refills            |

## 11. Minimum Harvest Time (S5 dip switch 4)

### **NOTICE**

Factory set for proper operation. Do not adjust. Adjustment outside the factory default setting may result in damage to the appliance.

| <b>S5 Dip Switch Setting</b> | <b>Minimum Harvest Timer</b> |
|------------------------------|------------------------------|
| <b>No. 4</b>                 |                              |
| OFF                          | 120 sec.                     |
| ON                           | 70 sec.                      |



## 12. Anti-Slush (S5 dip switch 5)

This dip switch setting provides anti-slush during the freeze cycle. When the evaporator temperature reaches 36°F (2.2°C) the control board reads a 5.8 kΩ signal from the thermistor and de-energizes the water pump for 10 sec. to melt the ice slush and prevent the ice slush from blocking the water supply tubing, causing irregular freeze patterns.

### **NOTICE**

Factory set for proper operation. Do not adjust. Adjustment outside the factory default setting may result in damage to the appliance.

| S5 Dip Switch Setting |                   |
|-----------------------|-------------------|
| <b>No. 5</b>          | <b>Anti-Slush</b> |
| OFF                   | Disabled          |
| ON                    | Enabled           |

## IV. Refrigeration Circuit and Component Service Information

### WARNING

- This appliance should be diagnosed and repaired only by qualified service personnel to reduce the risk of death, electric shock, serious injury, or fire.
- Move the control switch to the "OFF" position and turn off the power supply. Place the disconnect in the "OFF" position. Lockout/Tagout to prevent the power supply from being turned back on inadvertently.
- **CHOKING HAZARD:** Ensure all components, fasteners, and thumbscrews are securely in place after the icemaker is serviced. Make sure that none have fallen into the dispenser unit/ice storage bin.
- Make sure all food zones in the icemaker and dispenser unit/ice storage bin are clean after service.

### A. Refrigeration Circuit Service Information

#### WARNING

- Repairs requiring the refrigeration circuit to be opened must be performed by properly trained and EPA-certified service personnel.
- Use an electronic leak detector or soap bubbles to check for leaks. Add a trace of refrigerant to the system (if using an electronic leak detector), and then raise the pressure using nitrogen gas (140 PSIG). Do not use R-404A as a mixture with pressurized air for leak testing.

#### NOTICE

- Always recover the refrigerant and store it in an approved container. Do not discharge the refrigerant into the atmosphere.
- Do not leave the system open for longer than 15 min. when replacing or servicing parts. The Polyol Ester (POE) oils used in R-404A applications can absorb moisture quickly. Therefore it is important to prevent moisture from entering the system when replacing or servicing parts.
- Always install a new drier every time the sealed refrigeration system is opened. Do not replace the drier until after all other repair or replacement has been made. Install the new drier with the arrow on the drier in the direction of the refrigerant flow.
- When brazing, protect the drier by using a wet cloth to prevent the drier from overheating. Do not allow the drier to exceed 250°F (121°C).

#### 1. Refrigerant Recovery

The icemaker is provided with refrigerant access valves. Using proper refrigerant practices, recover the refrigerant. Store the refrigerant in an approved container. Do not discharge the refrigerant into the atmosphere.

## 2. Brazing

### **⚠ WARNING**

- R-404A itself is not flammable at atmospheric pressure and temperatures up to 176°F (80°C).
- R-404A itself is not explosive or poisonous. However, when exposed to high temperatures (open flames), R-404A can be decomposed to form hydrofluoric acid and carbonyl fluoride both of which are hazardous.
- Do not use silver alloy or copper alloy containing arsenic.

1) Braze all fittings while purging with nitrogen gas flowing at a pressure of 3 to 4 PSIG.

Note: Because the pipes in the evaporator case are specially coated to resist corrosion, it is important to make connections outside the evaporator case when possible. If it is necessary to braze inside the evaporator case, use sandpaper to remove the coating from the brazing connections before unbrazing the components.

### **NOTICE**

- Always install a new drier every time the sealed refrigeration system is opened.
- Do not replace the drier until after all other repair or replacement has been made. Install the new drier with the arrow on the drier in the direction of the refrigerant flow.
- When brazing, protect the drier by using a wet cloth to prevent the drier from overheating. Do not allow the drier to exceed 250°F (121°C).

2) Use an electronic leak detector or soap bubbles to check for leaks. Add a trace of refrigerant to the system (if using an electronic leak detector), and then raise the pressure using nitrogen gas (140 PSIG). Do not use R-404A as a mixture with pressurized air for leak testing.

## 3. Evacuation and Recharge (R-404A)

1) Attach a vacuum pump to the system. Be sure to connect the charging hoses to both high and low-side refrigerant access valves.

### **IMPORTANT**

The vacuum level and vacuum pump may be the same as those for current refrigerants. However, the rubber hose and gauge manifold to be used for evacuation and refrigerant charge should be exclusively for POE oils.

2) Turn on the vacuum pump. Open the gauge manifold valves. Never allow the oil in the vacuum pump to flow backwards.

3) Allow the vacuum pump to pull down to a 29.9" Hg vacuum. Evacuating period depends on pump capacity.

4) Close the low-side valve and high-side valve on the gauge manifold.

- 5) Disconnect the gauge manifold hose from the vacuum pump and attach it to a refrigerant service cylinder. Remember to loosen the connection and purge the air from the hose. For the required refrigerant charge, see the rating label inside the icemaker. Hoshizaki recommends only virgin refrigerant or reclaimed refrigerant which meets ARI Standard 700 (latest edition) be used.
- 6) A liquid charge is required when charging an R-404A system (to prevent fractionation). Place the service cylinder on the scales; if the service cylinder is not equipped with a dip tube, invert the service cylinder, then place it on the scales. Open the high-side valve on the gauge manifold.
- 7) Allow the system to charge with liquid until the proper charge weight is met.
- 8) If necessary, add any remaining charge to the system through the low-side.  
**NOTICE! To prevent compressor damage, use a throttling valve or liquid dispensing device to add the remaining liquid charge through the low-side refrigerant access valve with the icemaker running.**
- 9) Close the high and low-side gauge manifold valves, then disconnect the gauge manifold hoses.
- 10) Cap the refrigerant access valves to prevent a possible leak.

## B. Component Service Information

### **NOTICE**

When replacing a component listed below, see the notes to help ensure proper operation.

| <b>Component</b>                        | <b>Notes</b>  |
|---|---|
| Compressor                              | 1 phase: Install a new start capacitor, run capacitor, and start relay.   |
| Thermostatic Expansion Valves           | <ul style="list-style-type: none"> <li>• Attach the thermostatic expansion valve bulb to the suction line in the same location as the previous bulb.</li> <li>• The bulb should be between the 10 and 2 o'clock positions on the tube.</li> <li>• Secure the bulb with the clamp and holder, then insulate it.</li> </ul>   |
| Hot Gas Valves<br>Liquid Line<br>Valves | <ul style="list-style-type: none"> <li>• Replace the strainer if applicable.</li> <li>• Use copper tube of the same diameter and length when replacing valve lines.</li> </ul>  |
| Fan Motors                              | Install a new capacitor.  |
| Pump Motor                              | Install a new capacitor.  |
| Thermistor                              | <ul style="list-style-type: none"> <li>• Attach the new thermistor to the suction line in the same location as the previous thermistor.</li> <li>• The thermistor should be at the 12 o'clock position on the tube.</li> <li>• Smoothly fill the recessed area of the thermistor holder with high thermal conductive type sealant. Hoshizaki America part number 4A0683-01 (Silicone Heat Sink Compound 10-8108 manufactured by GC Electronics), KE-4560 RTV (manufactured by ShinEtsu Silicones), or equivalent are recommended.</li> <li>• Secure the thermistor with the holder, then insulate it.</li> <li>• Be very careful to prevent damage to the leads.</li> </ul> |

## V. Maintenance

The maintenance schedule below is a guideline. More frequent maintenance may be required depending on water quality, the appliance's environment, and local sanitation regulations

| <b>⚠ WARNING</b>  |  |
|---|--|
| <ul style="list-style-type: none"> <li>• Only qualified service technicians should service the appliance.</li> <li>• To reduce the risk of electric shock, do not touch the control switch or service switch with damp hands</li> <li>• Before servicing: Move the control switch to the "OFF" position and turn off the power supply. Place the disconnect in the "OFF" position.<br/>Lockout/Tagout to prevent the power supply from being turned back on inadvertently.</li> <li>• <b>CHOKING HAZARD:</b> Ensure all components, fasteners, and thumbscrews are securely in place after any maintenance is done to the icemaker. Make sure that none have fallen into the dispenser unit/ice storage bin.</li> </ul> |  |

| <b>Maintenance Schedule</b> |  |   |
|-----------------------------|--|---|
| <b>Frequency</b>            | <b>Area</b>  | <b>Task</b>   |
| Daily                       | Scoop  | Clean the ice scoop using a neutral cleaner. Rinse thoroughly after cleaning.   |
| Bi-Weekly                   | Air Filters  | Inspect. Wash with warm water and neutral cleaner if dirty.   |
| Monthly                     | External Water Filters                                 | Check for proper pressure and change if necessary.  |
|                             | Bin Control Lens                                       | Wipe down the bin control lens, (located on the bottom of the icemaker) with a neutral cleaner. Rinse thoroughly after cleaning   |
|                             | Icemaker Exterior                                      | Wipe down with a clean, soft cloth. Use a damp cloth containing a neutral cleaner to wipe off oil or dirt build up. Clean any chlorine staining (rust colored spots) using a non-abrasive cleanser. |
|                             | Underside of Icemaker and Top Kits; Bin Door and Snout | Wipe down with a clean cloth and warm water.  |
| Yearly                      | Icemaker and Dispenser Unit/Ice Storage Bin Liner      | Clean and sanitize per the cleaning and sanitizing instructions provided in the instruction manual or maintenance label on the icemaker.  |
|                             | Water Supply Inlet                                     | Close the icemaker water supply line shut-off valve and drain the water system. Clean the water supply inlet screen.  |
|                             | Condenser  | Inspect. Clean if necessary by using a brush or vacuum cleaner. More frequent cleaning may be required depending on location.   |
|                             | Water Hoses  | Inspect the water hoses and clean/replace if necessary.   |

## VI. Preparing the Appliance for Periods of Non-Use

### NOTICE

- When storing the appliance for an extended time or in sub-freezing temperatures, follow the instructions below to prevent damage.
- To prevent damage to the water pump, do not operate the appliance with the control switch in the "PUMP" position when the water tank is empty.

When the appliance is not used for two or three days under normal conditions, it is sufficient to move the control switch to the "OFF" position. When storing the appliance for an extended time or in sub-freezing temperatures, follow the instructions below.

#### 1. Remove the water from the icemaker water line:

- 1) Turn off the power supply, then remove the front panel.
- 2) Close the icemaker water supply line shut-off valve and open the icemaker water supply line drain valve.
- 3) Allow the line to drain by gravity.
- 4) Attach a compressed air or carbon dioxide supply to the icemaker water supply line drain valve.
- 5) Make sure at least 3 min. have elapsed since you turned off the power supply. Make sure the control switch is in the "ICE" position. Replace the front panel in its correct position, then turn on the power supply.
- 6) Blow the icemaker water supply line out using the compressed air or carbon dioxide supply.
- 7) Close the icemaker water supply line drain valve.

#### 2. Remove the water from the water tank:

- 1) Turn off the power supply, then remove the front panel.
- 2) Move the control switch to the "OFF" position.
- 3) Drain the water tank. remove the base cover, then disconnect one end of the pump tubing to drain the water tank. See Fig. 11. After the water tank has drained, reconnect the pump tubing.
- 4) Replace the base cover (if applicable) and front panel in their correct positions.
- 5) Remove all ice from the dispensing unit/ice storage bin. Clean the storage bin liner using a neutral cleaner. Rinse thoroughly after cleaning.

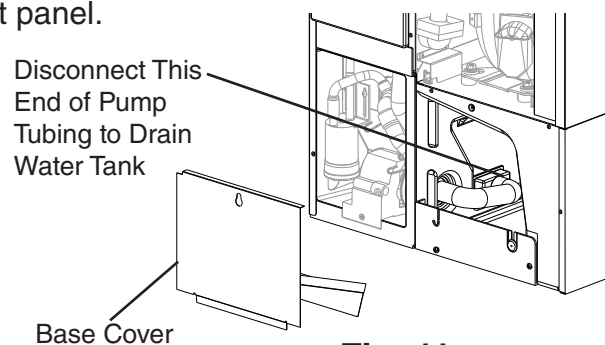

**Fig. 11**



---

## **VII. Disposal**

The appliance contains refrigerant and must be disposed of in accordance with applicable national, state, and local codes and regulations. Refrigerant must be recovered by properly certified service personnel.

## VIII. Technical Information

We reserve the right to make changes in specifications and design without prior notice.

### A. Specification and Performance Data Sheets

Pressure data is recorded at 5 min. into freezing cycle. The data not in bold should be used for reference only.

#### 1. KM-520MAJ-E

##### Specification Sheet

|   |  |             |  |         |         |         |            |            |            |
|---|--|-------------|--|---------|---------|---------|------------|------------|------------|
| AC SUPPLY VOLTAGE                                       | 230/1/50   |             |  |         |         |         |            |            |            |
| AMPERAGE  | 8.4 A (5 Min. Freeze AT 104°F/WT 80°F)   |             |  |         |         |         |            |            |            |
| MINIMUM CIRCUIT AMPACITY                                | 15 A   |             |  |         |         |         |            |            |            |
| MAXIMUM FUSE SIZE                                       | 15 A   |             |  |         |         |         |            |            |            |
| ELECTRIC & WATER CONSUMPTION                            | 90/70°F  | 70/50°F     |  |         |         |         |            |            |            |
| ELECTRIC W (kWH/100 lbs.)                               | 1180 (6.52)  | 1070 (4.88) |  |         |         |         |            |            |            |
| WATER gal./24HR (gal./100 lbs.)                         | 124 (28.5)   | 211 (40.1)  |  |         |         |         |            |            |            |
| APPROXIMATE ICE PRODUCTION PER 24 HR. FOR EUROPE MARKET | <table border="1"> <tr> <td>10/10°C</td> <td>20/15°C</td> <td>30/25°C</td> </tr> <tr> <td>*555 (252)</td> <td>*515 (234)</td> <td>*424 (192)</td> </tr> </table> |             |  | 10/10°C | 20/15°C | 30/25°C | *555 (252) | *515 (234) | *424 (192) |
| 10/10°C   | 20/15°C  | 30/25°C     |  |         |         |         |            |            |            |
| *555 (252)  | *515 (234)   | *424 (192)  |  |         |         |         |            |            |            |
| SHAPE OF ICE  | Crescent Cube  |             |  |         |         |         |            |            |            |
| ICE PRODUCTION PER CYCLE                                | 10.9 lbs. (4.9 kg) 480pcs.   |             |  |         |         |         |            |            |            |
| BIN CONTROL SYSTEM                                      | Ultra-Sonic Sensor   |             |  |         |         |         |            |            |            |
| REFRIGERANT CHARGE                                      | R404A, 1 lb. 1.7 oz. (500g)  |             |  |         |         |         |            |            |            |

##### Performance Data Sheet

| APPROXIMATE ICE PRODUCTION PER 24 HR.    | AMBIENT TEMP. (°F/°C)                         | WATER TEMP. (°F/°C) |             |             |             |           |             |
|--|---|---------------------|-------------|-------------|-------------|-----------|-------------|
|  |   | 50/10               |             | 70/21       |             | 90/32     |             |
|  | 70/21   | <b>525</b>          | <u>238</u>  | 498         | <u>226</u>  | 449       | <u>204</u>  |
|  | 80/27   | 505                 | <u>229</u>  | 463         | <u>210</u>  | 407       | <u>185</u>  |
|  | 90/32   | 498                 | <u>226</u>  | <b>434</b>  | <u>197</u>  | 380       | <u>172</u>  |
| lbs./day kg./day                         | 100/38  | 484                 | <u>220</u>  | 421         | <u>191</u>  | 330       | <u>150</u>  |
| APPROXIMATE ELECTRIC CONSUMPTION         | 70/21   | <b>1070</b>         |             | 1102        |             | 985       |             |
|  | 80/27   | 1095                |             | 1145        |             | 937       |             |
|  | 90/32   | 1102                |             | <b>1180</b> |             | 1008      |             |
| watts                                    | 100/38  | 1024                |             | 1140        |             | 850       |             |
| APPROXIMATE WATER CONSUMPTION PER 24 HR. | 70/21   | <b>211</b>          | <u>0.80</u> | 185         | <u>0.70</u> | 165       | <u>0.63</u> |
|  | 80/27   | 191                 | <u>0.72</u> | 152         | <u>0.57</u> | 140       | <u>0.53</u> |
|  | 90/32   | 185                 | <u>0.70</u> | <b>124</b>  | <u>0.47</u> | 108       | <u>0.41</u> |
| gal./day m <sup>3</sup> /day             | 100/38  | 153                 | <u>0.58</u> | 120         | <u>0.46</u> | <b>94</b> | <u>0.36</u> |
| FREEZING CYCLE TIME                      | 70/21   | <b>22</b>           |             | 23          |             | 26        |             |
|  | 80/27   | 23                  |             | 25          |             | 28        |             |
|  | 90/32   | 23                  |             | <b>26</b>   |             | 29        |             |
| min.                                     | 100/38  | 24                  |             | 27          |             | 32        |             |
| HARVEST CYCLE TIME                       | 70/21   | <b>3.4</b>          |             | 3.0         |             | 2.8       |             |
|  | 80/27   | 3.0                 |             | 2.4         |             | 2.5       |             |
|  | 90/32   | 3.0                 |             | <b>2.0</b>  |             | 2.0       |             |
| min.                                     | 100/38  | 2.5                 |             | 2.0         |             | 2.0       |             |
| HEAD PRESSURE                            | 70/21   | <b>215</b>          | <u>15.1</u> | 234         | <u>16.5</u> | 266       | <u>18.7</u> |
|  | 80/27   | 230                 | <u>16.1</u> | 259         | <u>18.2</u> | 294       | <u>20.6</u> |
|  | 90/32   | 234                 | <u>16.5</u> | <b>280</b>  | <u>19.7</u> | 314       | <u>22.1</u> |
| PSIG kg/cm <sup>2</sup> G                | 100/38  | 242                 | <u>17.0</u> | 288         | <u>20.2</u> | 345       | <u>24.3</u> |
| SUCTION PRESSURE                         | 70/21   | <b>40</b>           | <u>2.8</u>  | 43          | <u>3.0</u>  | 48        | <u>3.4</u>  |
|  | 80/27   | 42                  | <u>3.0</u>  | 47          | <u>3.3</u>  | 52        | <u>3.7</u>  |
|  | 90/32   | 43                  | <u>3.0</u>  | <b>50</b>   | <u>3.5</u>  | 55        | <u>3.9</u>  |
| PSIG kg/cm <sup>2</sup> G                | 100/38  | 44                  | <u>3.1</u>  | 51          | <u>3.6</u>  | 60        | <u>4.2</u>  |
| TOTAL HEAT OF REJECTION FROM CONDENSER   | 7,300 BTU/h [AT 90°F (32°C) / WT 70°F (21°C)] |                     |             |             |             |           |             |
| TOTAL HEAT OF REJECTION FROM COMPRESSOR  | 1,400 BTU/h [AT 90°F (32°C) / WT 70°F (21°C)] |                     |             |             |             |           |             |

## 2. KM-660MAJ-E

### Specification Sheet

|  |  |             |  |         |         |         |            |            |            |
|--|--|-------------|--|---------|---------|---------|------------|------------|------------|
| AC SUPPLY VOLTAGE                                      | 230/1/50   |             |  |         |         |         |            |            |            |
| AMPERAGE   | 8.4 A (5 Min. Freeze AT 104°F/WT 80°F)   |             |  |         |         |         |            |            |            |
| MINIMUM CIRCUIT AMPACITY                               | 15 A   |             |  |         |         |         |            |            |            |
| MAXIMUM FUSE SIZE                                      | 15 A   |             |  |         |         |         |            |            |            |
| ELECTRIC & WATER CONSUMPTION                           | 90/70°F  | 70/50°F     |  |         |         |         |            |            |            |
| ELECTRIC W (kWH/100 lbs.)                              | 1170 (4.85)  | 1080 (4.18) |  |         |         |         |            |            |            |
| WATER gal./24HR (gal./100 lbs.)                        | 79 (13.7)  | 161 (26.1)  |  |         |         |         |            |            |            |
| APPROXIMATE ICE PRODUCTION PER 24 HR.FOR EUROPE MARKET | <table border="1"> <tr> <td>10/10°C</td> <td>20/15°C</td> <td>30/25°C</td> </tr> <tr> <td>*648 (294)</td> <td>*608 (276)</td> <td>*568 (258)</td> </tr> </table> |             |  | 10/10°C | 20/15°C | 30/25°C | *648 (294) | *608 (276) | *568 (258) |
| 10/10°C  | 20/15°C  | 30/25°C     |  |         |         |         |            |            |            |
| *648 (294)   | *608 (276)   | *568 (258)  |  |         |         |         |            |            |            |
| SHAPE OF ICE   | Crescent Cube  |             |  |         |         |         |            |            |            |
| ICE PRODUCTION PER CYCLE                               | 10.9 lbs. (4.9 kg) 480pcs.   |             |  |         |         |         |            |            |            |
| BIN CONTROL SYSTEM                                     | Ultra-Sonic Sensor   |             |  |         |         |         |            |            |            |
| REFRIGERANT CHARGE                                     | R404A, 1 lb. 10.9 oz. (760g)   |             |  |         |         |         |            |            |            |

### Performance Data Sheet

| APPROXIMATE ICE PRODUCTION PER 24 HR.    | AMBIENT TEMP. (°F/°C)                         | WATER TEMP. (°F/°C) |             |             |             |           |             |
|--|---|---------------------|-------------|-------------|-------------|-----------|-------------|
|  |   | 50/10               |             | 70/21       |             | 90/32     |             |
|  | 70/21   | <b>618</b>          | <u>280</u>  | 606         | <u>275</u>  | 565       | <u>256</u>  |
|  | 80/27   | 609                 | <u>276</u>  | 591         | <u>268</u>  | 536       | <u>243</u>  |
|  | 90/32   | 606                 | <u>275</u>  | <b>578</b>  | <u>262</u>  | 528       | <u>240</u>  |
| lbs./day kg./day                         | 100/38  | 590                 | <u>267</u>  | 566         | <u>257</u>  | 482       | <u>219</u>  |
| APPROXIMATE ELECTRIC CONSUMPTION         | 70/21   | <b>1080</b>         |             | 1106        |             | 1142      |             |
|  | 80/27   | 1100                |             | 1141        |             | 1177      |             |
|  | 90/32   | 1106                |             | <b>1170</b> |             | 1206      |             |
| watts                                    | 100/38  | 1113                |             | 1179        |             | 1240      |             |
| APPROXIMATE WATER CONSUMPTION PER 24 HR. | 70/21   | <b>161</b>          | <u>0.61</u> | 137         | <u>0.52</u> | 124       | <u>0.47</u> |
|  | 80/27   | 143                 | <u>0.54</u> | 106         | <u>0.40</u> | 104       | <u>0.39</u> |
|  | 90/32   | 137                 | <u>0.52</u> | <b>79</b>   | <u>0.30</u> | 72        | <u>0.27</u> |
| gal./day m <sup>3</sup> /day             | 100/38  | 109                 | <u>0.41</u> | 77          | <u>0.29</u> | <b>66</b> | <u>0.25</u> |
| FREEZING CYCLE TIME                      | 70/21   | <b>22</b>           |             | 23          |             | 26        |             |
|  | 80/27   | 23                  |             | 25          |             | 28        |             |
|  | 90/32   | 23                  |             | <b>26</b>   |             | 29        |             |
| min.                                     | 100/38  | 24                  |             | 27          |             | 32        |             |
| HARVEST CYCLE TIME                       | 70/21   | <b>3.4</b>          |             | 3.0         |             | 2.8       |             |
|  | 80/27   | 3.0                 |             | 2.4         |             | 2.5       |             |
|  | 90/32   | 3.0                 |             | <b>2.0</b>  |             | 2.0       |             |
| min.                                     | 100/38  | 2.5                 |             | 2.0         |             | 2.0       |             |
| HEAD PRESSURE                            | 70/21   | <b>215</b>          | <u>15.1</u> | 234         | <u>16.5</u> | 266       | <u>18.7</u> |
|  | 80/27   | 230                 | <u>16.1</u> | 259         | <u>18.2</u> | 294       | <u>20.6</u> |
|  | 90/32   | 234                 | <u>16.5</u> | <b>280</b>  | <u>19.7</u> | 314       | <u>22.1</u> |
| PSIG kg/cm <sup>2</sup> G                | 100/38  | 242                 | <u>17.0</u> | 288         | <u>20.2</u> | 345       | <u>24.3</u> |
| SUCTION PRESSURE                         | 70/21   | <b>40</b>           | <u>2.8</u>  | 43          | <u>3.0</u>  | 48        | <u>3.4</u>  |
|  | 80/27   | 42                  | <u>3.0</u>  | 47          | <u>3.3</u>  | 52        | <u>3.7</u>  |
|  | 90/32   | 43                  | <u>3.0</u>  | <b>50</b>   | <u>3.5</u>  | 55        | <u>3.9</u>  |
| PSIG kg/cm <sup>2</sup> G                | 100/38  | 44                  | <u>3.1</u>  | 51          | <u>3.6</u>  | 60        | <u>4.2</u>  |
| TOTAL HEAT OF REJECTION FROM CONDENSER   | 7,300 BTU/h [AT 90°F (32°C) / WT 70°F (21°C)] |                     |             |             |             |           |             |
| TOTAL HEAT OF REJECTION FROM COMPRESSOR  | 1,400 BTU/h [AT 90°F (32°C) / WT 70°F (21°C)] |                     |             |             |             |           |             |

# B. Wiring Diagrams

## 1. K Control Board (2A8242-02) Ultrasonic Control Board (4A6838-01) KM-550MAJ-E Auxiliary Code L-0(B) and Earlier KM-660MAJ-E Auxiliary Code L-1(J) and Earlier

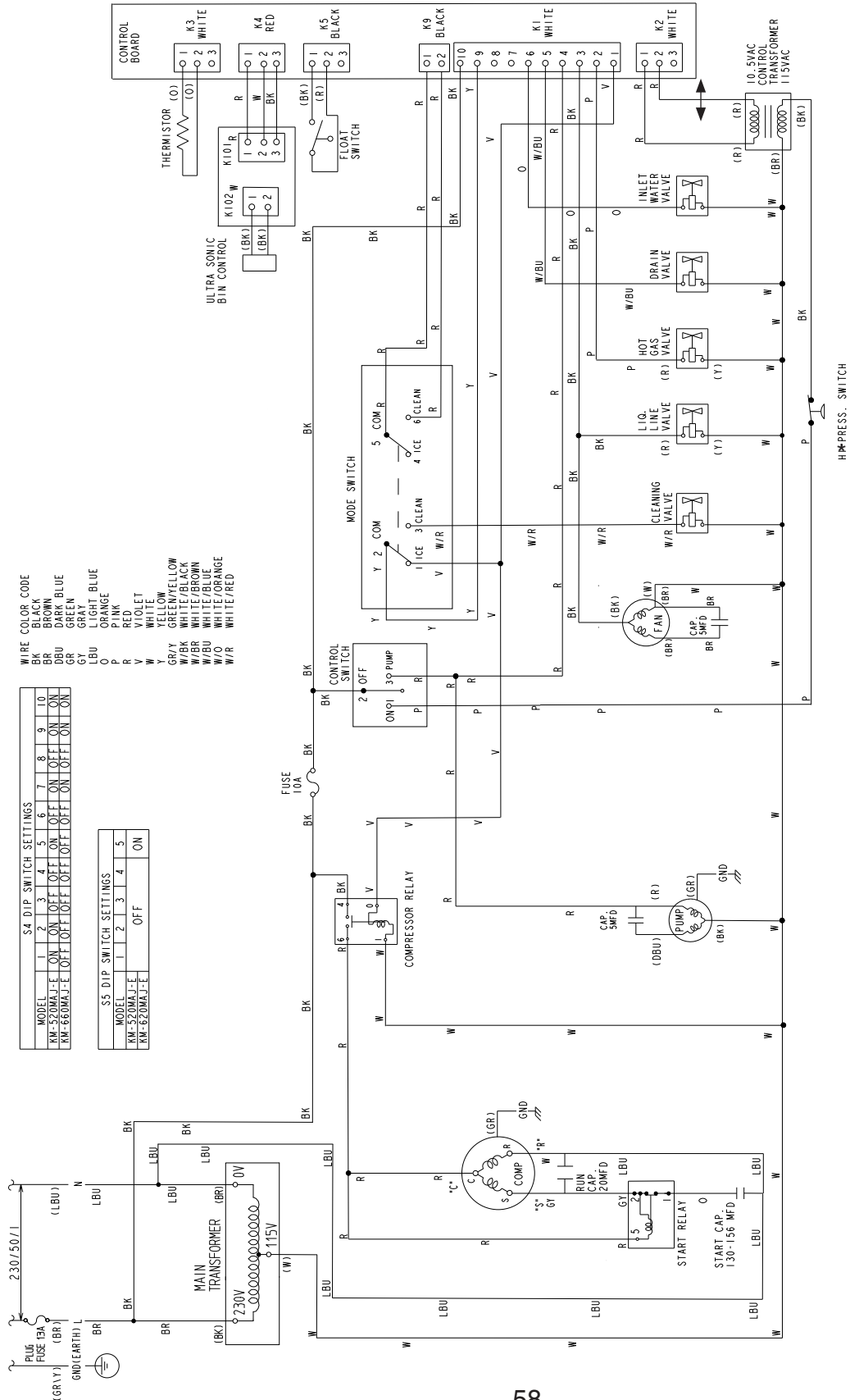

**WIRE COLOR CODE**

|      |              |
|------|--------------|
| BK   | BLACK        |
| BR   | BROWN        |
| DBU  | DARK BLUE    |
| GR   | GREEN        |
| GY   | GRAY         |
| LBU  | LIGHT BLUE   |
| O    | ORANGE       |
| P    | PINK         |
| R    | RED          |
| V    | VIOLET       |
| Y    | YELLOW       |
| W    | WHITE        |
| W/BK | WHITE/BLACK  |
| W/BR | WHITE/BROWN  |
| W/BU | WHITE/BLUE   |
| W/O  | WHITE/ORANGE |
| W/R  | WHITE/RED    |

**S4 DIP SWITCH SETTINGS**

| MODEL       | 1   | 2   | 3   | 4   | 5   | 6   | 7   | 8   | 9   | 10 |
|-------------|-----|-----|-----|-----|-----|-----|-----|-----|-----|----|
| KM-520MAJ-E | ON  | ON  | OFF | OFF | ON  | OFF | ON  | OFF | ON  | ON |
| KM-660MAJ-E | OFF | OFF | OFF | OFF | OFF | OFF | OFF | OFF | OFF | ON |

**S5 DIP SWITCH SETTINGS**

| MODEL       | 1   | 2   | 3   | 4   | 5  |
|-------------|-----|-----|-----|-----|----|
| KM-520MAJ-E | OFF | OFF | OFF | OFF | ON |
| KM-620MAJ-E | OFF | OFF | OFF | OFF | ON |

**\* High-Pressure Switch**

|                       |
|-----------------------|
| Air Models            |
| Cut-out 412 ± 20 PSIG |
| Cut-in 327 ± 22 PSIG  |

## 2. K+ Control Board (2A9678-01) KM-550MAJ-E Auxiliary Code L-0(C) and Later KM-660MAJ-E Auxiliary Code L-1(K) and Later

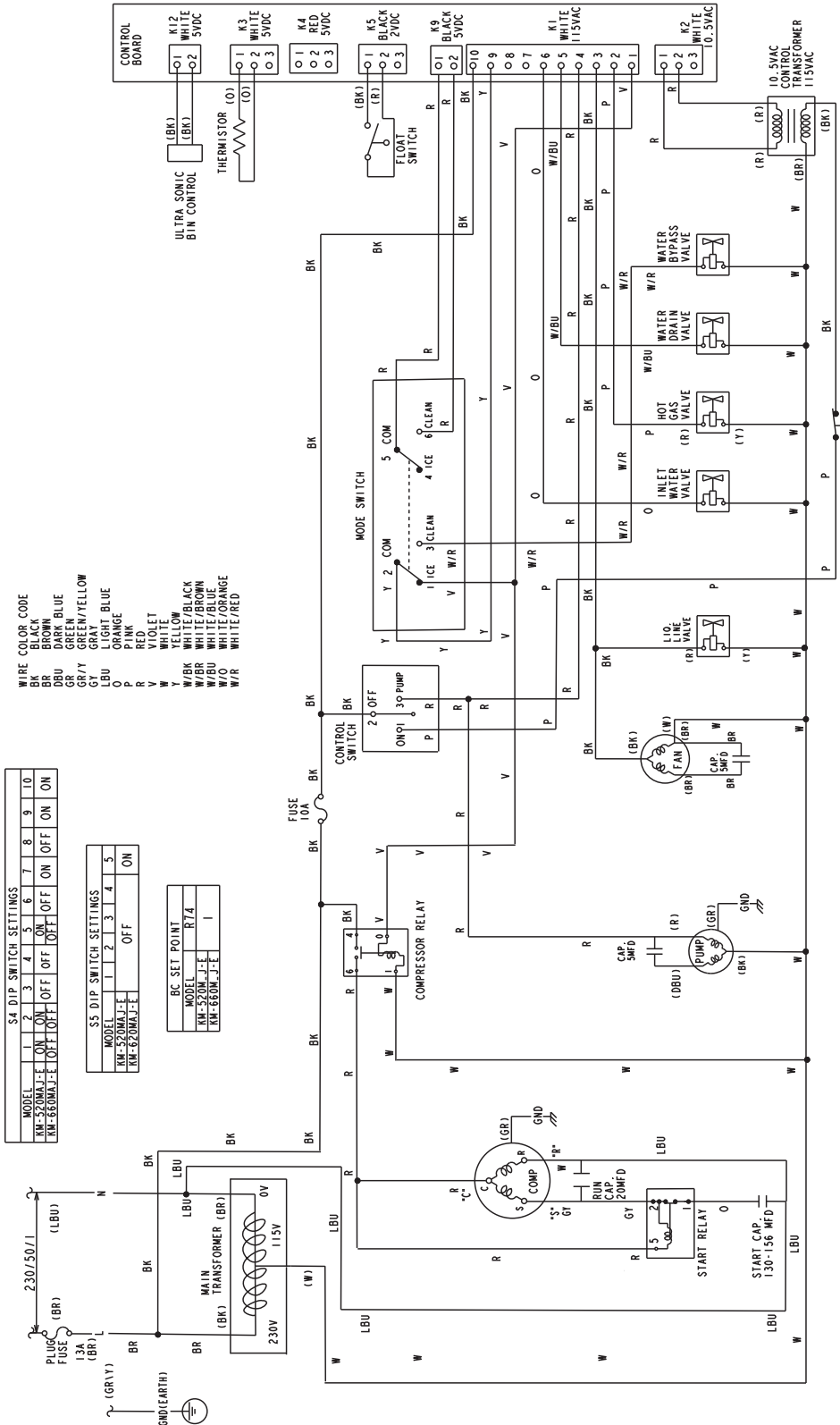

- WIRE COLOR CODE**
- BK BLACK
  - DBU DARK BLUE
  - GR GREEN/YELLOW
  - GY GRAY
  - LBU LIGHT BLUE
  - OR ORANGE
  - P PINK
  - R RED
  - V VIOLET
  - W WHITE
  - Y YELLOW
  - W/BK WHITE/BLACK
  - W/BR WHITE/BROWN
  - W/BU WHITE/BLUE
  - W/O WHITE/ORANGE
  - W/R WHITE/RED

**S4 DIP SWITCH SETTINGS**

| MODEL       | 1   | 2   | 3   | 4   | 5   | 6   | 7   | 8   | 9   | 10 |
|-------------|-----|-----|-----|-----|-----|-----|-----|-----|-----|----|
| KM-550MAJ-E | ON  | ON  | OFF | OFF | OFF | OFF | OFF | OFF | ON  | ON |
| KM-660MAJ-E | OFF | OFF | OFF | OFF | OFF | OFF | OFF | OFF | OFF | ON |

**S5 DIP SWITCH SETTINGS**

| MODEL       | 1   | 2   | 3   | 4   | 5   |
|-------------|-----|-----|-----|-----|-----|
| KM-550MAJ-E | ON  | OFF | OFF | OFF | OFF |
| KM-660MAJ-E | OFF | OFF | OFF | OFF | ON  |

**RC SET POINT**

| MODEL       | RT/4 |
|-------------|------|
| KM-550MAJ-E | 1    |
| KM-660MAJ-E | 1    |

|                        |
|------------------------|
| * High-Pressure Switch |
| Air Models             |
| Cut-out 412±20 PSIG    |
| Cut-in 327±22 PSIG     |