



HOSHIZAKI

Parts List

Modular Crescent Cuber

Model

KMD-410MAH



[hoshizakiamerica.com](https://www.hoshizakiamerica.com)

Number: F043-3237
Issued: 09-2024

Auxiliary Codes

KMD-410MAH	U-1	July 2009
	V-0	January 2010
	V-1	February 2010
	V-2	July 2010
	A-0	January 2011
	A-1	April 2011
	F-0	January 2016
	F-1	May 2016

Auxiliary Code Breakdown

The auxiliary code is the first two characters in the serial number. The first character indicates the year. Years progress or regress in alphabetical order. The series runs from "A" through "V" and the letters "I" and "O" are skipped. The second character indicates significant part changes within a year. Base is "0" and this number advances for each change. In cases where there is a letter in parentheses, this designates the month. This is the last character in the serial number. The series runs from "(A)" through "(M)" and the letter "(I)" is skipped. This designation is only included when identifying a parts change within an auxiliary code.

Note About Ordering Parts

Most assemblies cannot be ordered as complete units; parts in the assemblies generally must be ordered separately.

MARKS LOCATED UNDER THE AUXILIARY CODE

- = Part deleted.
- x = Part deleted and replaced by "o" part.
- o = New part in place of "x" part.

FASTENER PART NUMBER

SCREWS

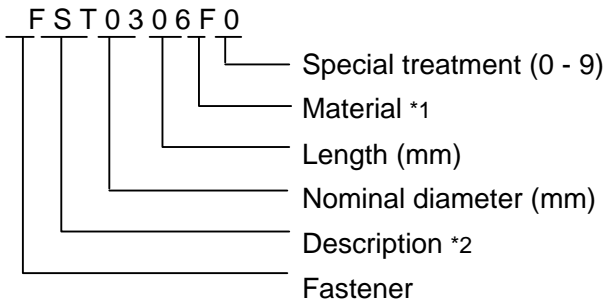

*1 Material

- F: Steel
- S: Austenitic stainless steel
- M: Martensitic stainless steel
- B: Copper alloy
- P: Polycarbonate
- N: Polyamide
- V: PVC
- A: ABS
- X: Polyacetal
- L: Aluminum

NUTS & WASHERS

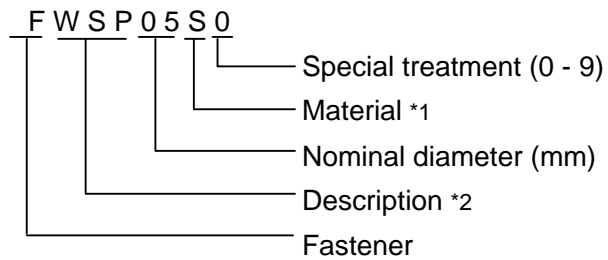

*2 Description

- First letter
- S: Machine screw
- T: Tapping screw
- M: Wood screw
- B: Bolt
- W: Washer
- N: Nut

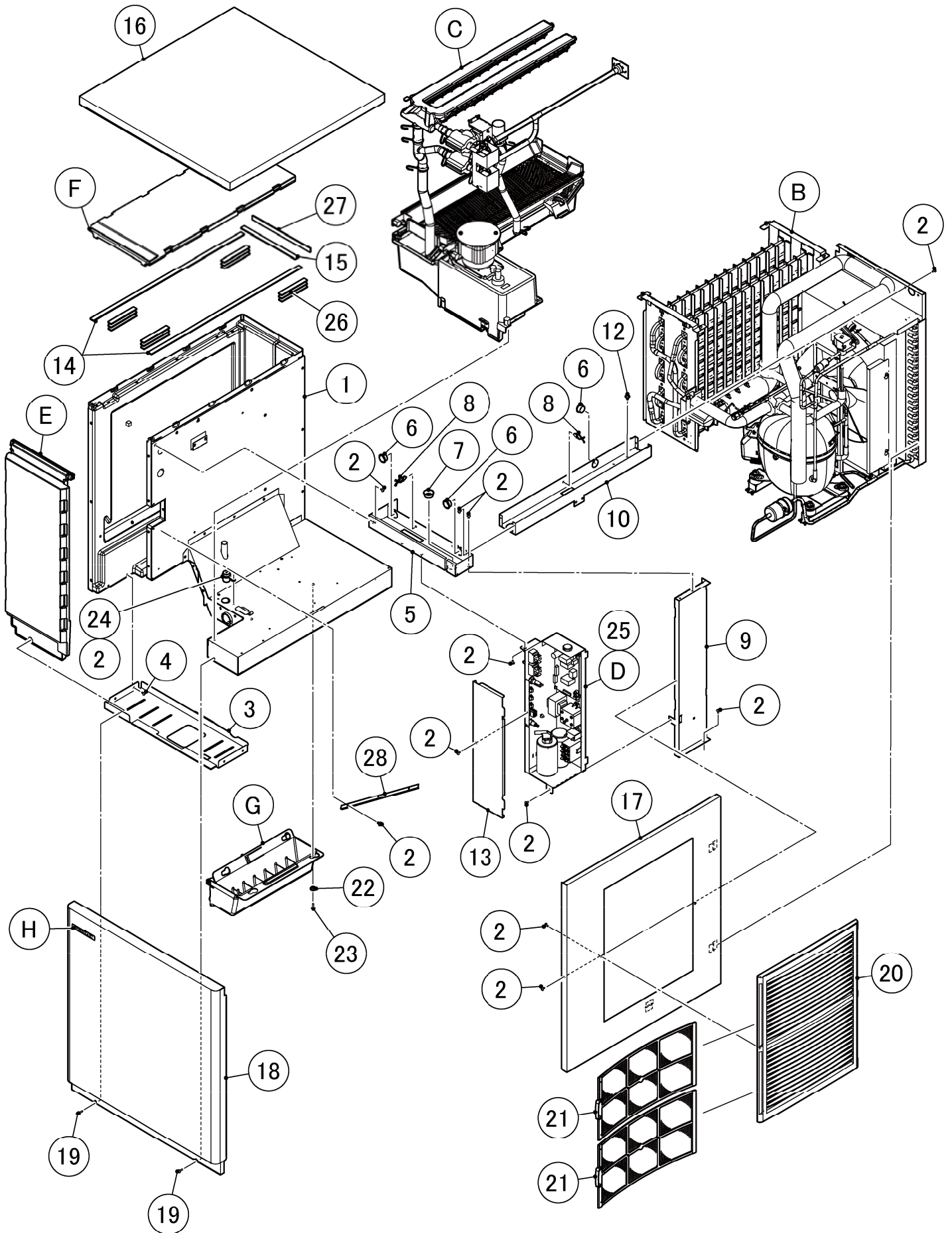

HA

MODEL: KMD-410MAH		TITLE: A. ICE CUBER ASSY					
INDEX NO.	DESCRIPTION	MATERIAL OR MODEL NUMBER	PART NUMBER	REQ'D NUMBER			
				U-1,V-0	V-1	V-2,A-0	A-1
B	REFRIGERATION CIRCUIT		-	1	1	1	1
C	WATER CIRCUIT		-	1	1	1	1
D	CONT. BOX ASSY		-	1	1	1	1
E	FRONT INSULATION ASSY		371887A01	1	1	1	1
F	TOP INSULATION ASSY		374537A01	1	1	1	1
G	BIN SWITCH		-	1	1	1	1
H	LABEL LOCATION		-	1	1	1	1
K	ACCESSORIES		-	1	1	1	1
1	EVAP. CASE		119110G04	1	1	1	1
2	T2 SCREW	4X8	FT20408F0	17	17	17	20
3	BOTTOM FRAME		371876M01	1	1	1	1
4	T2 SCREW	4X8 SUS	FT20408M0	4	4	4	4
5	TOP FRAME		371867M01	1	1	1	1
6	BUSHING	OCB-875	428394-04	3	3	3	3
7	BUSHING	OCB-750	428394-01	1	1	1	1
8	CLAMP	No.249	427902-03	2	2	3	3
9	SIDE FRAME (A)		371873M01	1	1	1	1
10	SIDE FRAME (B)		371866M01	1	1	1	1
11	SQUARE WASHER		433537-02	4	4	4	4
12	SCREW - GROUNDING		433304-02	1	1	1	1
13	CONT. BOX COVER		371874M01	1	1	1	1
14	GASKET	L=563	119818Z01	2	2	2	2
15	GASKET	L=203	119818Z02	1	1	1	1
16	TOP PANEL		255967M02	1	1	1	1
17	SIDE PANEL (R)		255966G03	1	1	1	1
18	FRONT PANEL		373166G01	1	1	1	1
19	TRUSS HEAD SCREW	4X20 SUS	FST0420S0	2	2	2	2
20	LOUVER		1A1329-01 (120457P01)	1	1	1	1

HA

MODEL: KMD-410MAH		TITLE: A. ICE CUBER ASSY						
INDEX NO.	DESCRIPTION	MATERIAL OR MODEL NUMBER	PART NUMBER	REQ'D NUMBER				
				U-1 V-0	V-1	V-2 A-0	A-1 F-0	F-1
21	AIR FILTER		2A4128G01 (258589G01)	2	2	2	2	2
22	COLLAR		435269-01	4	4	4	4	4
23	T2 SCREW	4X16 SUS	FT20416M0	4	4	4	4	4
24	HOLE PLUG		373078R01	1	1	1	1	1
25	WIRE HARNESS		373139Z01	1	1	1	1	1
26	GASKET	L=50	119818Z03	12	12	12	12	12
27	GASKET	L=215	119818Z04	1	1	1	1	1
28	PLATE - SIDE PANEL		379577M01	-	-	-	1	1

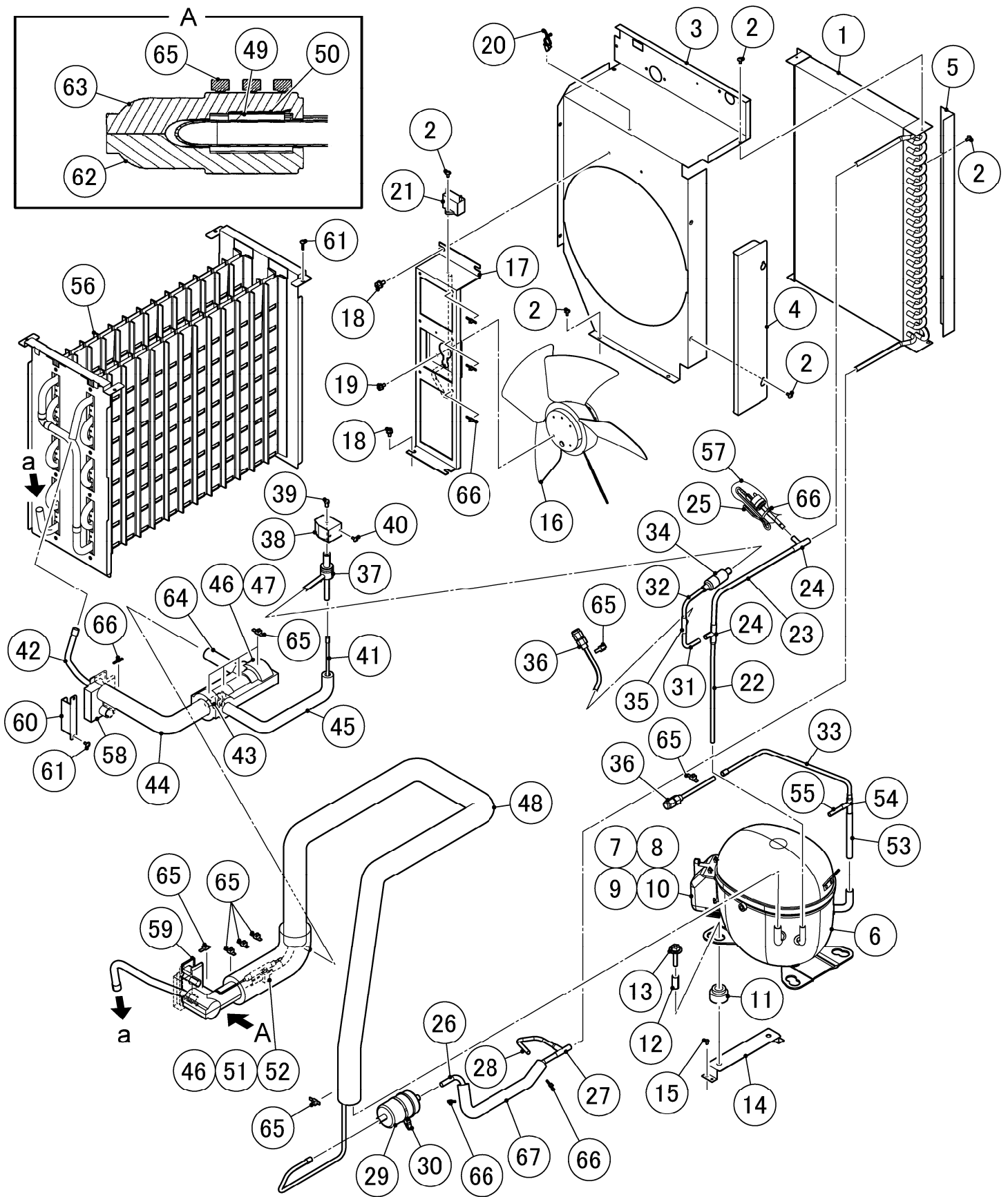

HA

MODEL: KMD-410MAH		TITLE: B. REFRIGERATION CIRCUIT						
INDEX NO.	DESCRIPTION	MATERIAL OR MODEL NUMBER	PART NUMBER	REQ'D NUMBER				
				U-1 V-0	V-1	V-2 A-0	A-1 F-0	F-1
1	CONDENSER		P00815-01	1	1	1	1	1
2	T2 SCREW	4X8	FT20408F0	16	16	16	16	16
3	SHROUD		255968M02	1	1	1	1	1
4	FAN BLADE COVER		371865M01	1	1	1	1	1
5	BARRIER		371872M01	1	1	1	1	1
6	COMPRESSOR	NT6217GKV 115V 60Hz	P01550-01	1	1	1	1	1
7	TERMINAL COVER	COMP. ACCESSORY	P02814-01	1	1	1	1	1
8	PROTECTOR	COMP. ACCESSORY	P01552-01	1	1	1	1	1
9	PROTECTOR RETAINER	COMP. ACCESSORY	P02815-01	1	1	1	1	1
10	SCREW	COMP. ACCESSORY	P00840-01	1	1	1	1	1
11	GROMMET	COMP. ACCESSORY	P00846-01	4	4	4	4	4
12	SPACER	COMP. ACCESSORY	P00847-01	4	4	4	4	4
13	BOLT	M8X35	436206-03	4	4	4	4	4
14	COMP. MOUNT		371868G01	2	2	2	2	2
15	RIVET	SSD43SSBS	7170-0005	8	8	8	8	8
16	FAN MOTOR	A4E300-AU26-07	P02596-01	1	1	1	1	1
17	FAN MOTOR BRACKET		371870G01	1	1	1	1	1
18	HEX HEAD BOLT W/WASHER [SW]	5X10 SUS	FBK0510S0	4	4	4	4	4
19	HEX HEAD BOLT W/WASHER [SW]	4X8 SUS	FBK0408S0	3	3	3	3	3
20	CLAMP	No. 249	427902-03	1	1	1	1	1
21	CAPACITOR	UJ22B605UEF	443158-02	1	1	1	1	1
22	COPPER TUBE (A1) - HIGH SIDE	COPPER TUBE (A) - HIGH SIDE 371884G01	371884M01	1	1	1	1	1
23	COPPER TUBE (A2) - HIGH SIDE	COPPER TUBE (A) - HIGH SIDE 371884G01	371884M02	1	1	1	1	1
24	TEE	COPPER TUBE (A) - HIGH SIDE 371884G01	420041-02	2	2	2	2	2

HA

MODEL: KMD-410MAH		TITLE: B. REFRIGERATION CIRCUIT						
INDEX NO.	DESCRIPTION	MATERIAL OR MODEL NUMBER	PART NUMBER	REQ'D NUMBER				
				U-1 V-0	V-1	V-2 A-0	A-1 F-0	F-1
25	PRESSURE SWITCH	ACB-1UB44	463180-04	1	1	1	1	1
26	COPPER TUBE (B1) - HIGH SIDE	COPPER TUBE (B) - HIGH SIDE 255971G01	255971M01	1	1	1	1	1
27	TEE	COPPER TUBE (B) - HIGH SIDE 255971G01	420041-11	1	1	1	1	1
28	COPPER TUBE (B2) - HIGH SIDE	COPPER TUBE (B) - HIGH SIDE 255971G01	255971M03	1	1	1	1	1
29	DRIER	DML032.5s	462965-01	1	1	1	-	-
		DML032S	P02070-01				1	1
30	PUSH MOUNT TIE	T50RSF	436156-02	1	1	1	1	1
31	COPPER TUBE (D1) - HIGH SIDE	COPPER TUBE (D) - HIGH SIDE 371885G01	371885M01	1	1	1	1	1
32	COPPER TUBE (D2) - HIGH SIDE	COPPER TUBE (D) - HIGH SIDE 371885G01	371885M02	1	1	1	1	1
33	COPPER TUBE (F3) - ACCESS VALVE	COPPER TUBE (F) - ACCESS VALVE 371877G01	371877M04	1	1	1	1	1
34	STRAINER	COPPER TUBE (D) - HIGH SIDE 371885G01	P00812-01	1	1	1	1	1
35	TEE	COPPER TUBE (D) - HIGH SIDE 371885G01	417394-01	1	1	1	1	1
36	ACCESS VALVE	TCJ-2F20NH DU-1	457729-01	2	2	2	2	2
37	VALVE BODY	ATS-B7SHDU-2	4A3978-01	1	1	1	1	1
38	COIL-VALVE	AMS-C12H DU-3	4A3277-01	1	1	1	1	1
39	BOLT	M4X8	4A3277F01	1	1	1	1	1

HA

MODEL: KMD-410MAH		TITLE: B. REFRIGERATION CIRCUIT						
INDEX NO.	DESCRIPTION	MATERIAL OR MODEL NUMBER	PART NUMBER	REQ'D NUMBER				
				U-1 V-0	V-1	V-2 A-0	A-1 F-0	F-1
40	TRUSS HEAD SCREW	4X8 SUS	FST0408S0	2	2	2	2	2
41	COPPER TUBE (E1) - HOT GAS	COPPER TUBE (E) - HOT GAS 371883G01	371878M01	1	1	1	1	1
42	COPPER TUBE (E2) - HOT GAS	COPPER TUBE (E) - HOT GAS 371883G01	371880M01	1	1	1	1	1
43	TEE	COPPER TUBE (E) - HOT GAS 371883G01	420335-01	1	1	1	1	1
44	INSULATION TUBE	COPPER TUBE (E) - HOT GAS 371883G01 L=290	H71030290	1	1	1	1	1
45	INSULATION TUBE	COPPER TUBE (E) - HOT GAS 371883G01 L=360	H71020360	1	1	1	1	1
46	EXP. VALVE	HFE-10NHD-2	4A1414-01	1	1	1	1	1
47	EXPANSION VALVE COVER		3A0944-01	1	1	1	1	1
48	HEAT EXCHANGER		255974G01	1	1	1	1	1
49	THERMISTOR	NBFC-36-H60-1	P00027-01	1	1	1	1	1
50	HOLDER - THERMISTOR		427430-01	1	1	1	1	1
51	HOLDER / EXP. VALVE - 3/8		3A0107-01	1	1	1	1	1
52	CLAMP		443461-02	1	1	1	1	1
53	COPPER TUBE (F1) - ACCESS VALVE	COPPER TUBE (F) - ACCESS VALVE 371877G01	371877M01	1	1	1	1	1
54	TEE	COPPER TUBE (F) - ACCESS VALVE 371877G01	417394-01	1	1	1	1	1

HA

MODEL: KMD-410MAH		TITLE: B. REFRIGERATION CIRCUIT						
INDEX NO.	DESCRIPTION	MATERIAL OR MODEL NUMBER	PART NUMBER	REQ'D NUMBER				
				U-1 V-0	V-1	V-2 A-0	A-1 F-0	F-1
55	COPPER TUBE (F2) - ACCESS VALVE	COPPER TUBE (F) - ACCESS VALVE 371877G01	371877M03	1	1	1	1	1
56	EVAPORATOR ASSY		257091G01	1	1	1	1	1
57	BAG		4X1559-01	1	1	1	1	1
58	RUBBER INSULATION (B)		3A1045-01	1	1	1	1	1
59	RUBBER INSULATION (A)		3A1044-01	1	1	1	1	1
60	INSULATION HOLDER		473043M01	1	1	1	1	1
61	T2 SCREW	4X8 SUS	FT20408M0	6	6	6	6	6
62	INSULATION - THERMISTOR (A)		439368-01	1	1	1	1	1
63	INSULATION - THERMISTOR (B)		439368-02	1	1	1	1	1
64	INSULATION TUBE	L=90	7762-1020	1	1	1	1	1
65	TIE	CV-200	7920-0010	14	14	14	14	14
66	TIE	CV-100	7920-0002	7	7	7	7	7
67	INSULATION TUBE	L=245	H71020245	1	1	1	1	1

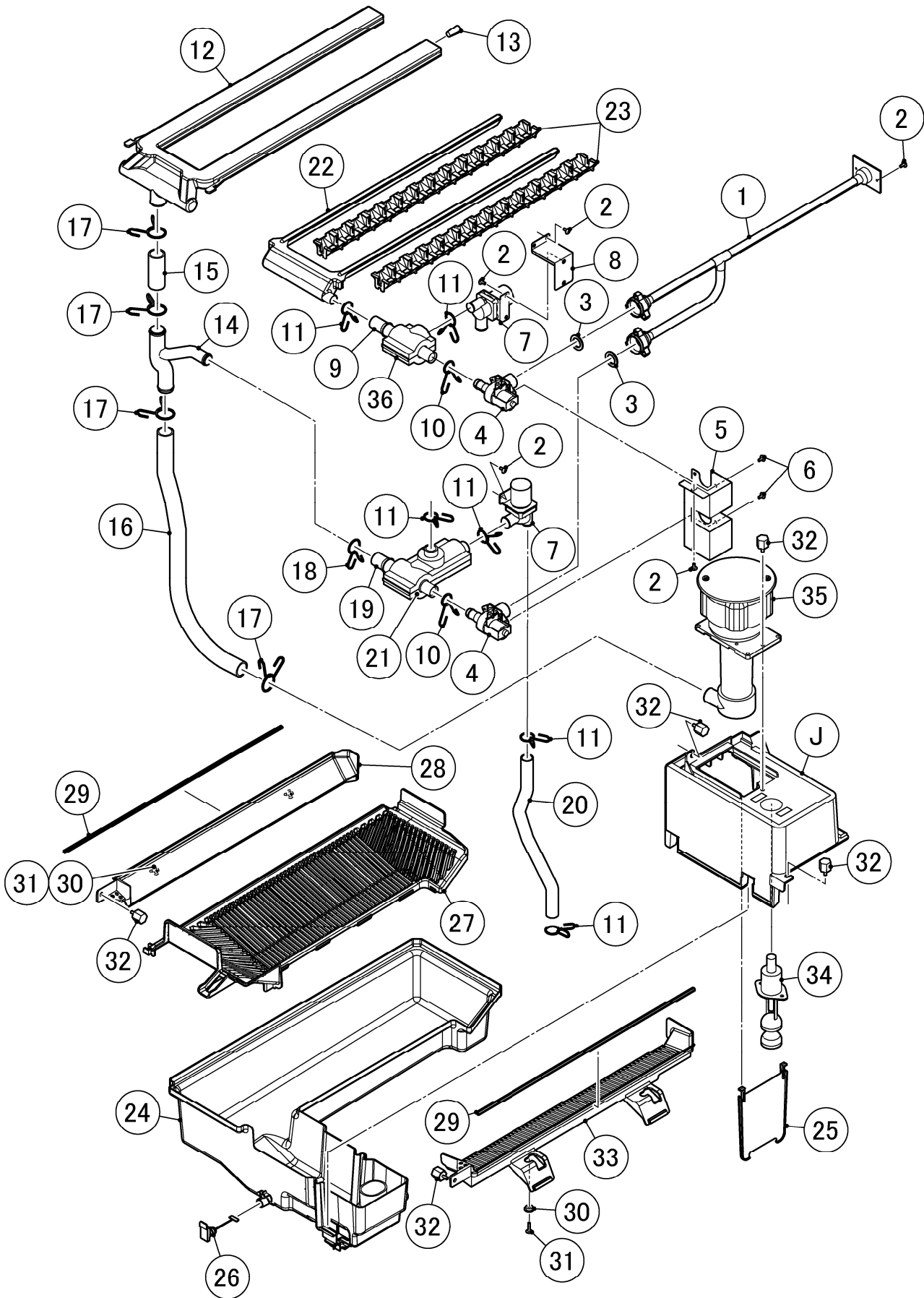

HA

MODEL: KMD-410MAH		TITLE: C. WATER CIRCUIT ASSY						
INDEX NO.	DESCRIPTION	MATERIAL OR MODEL NUMBER	PART NUMBER	REQ'D NUMBER				
				U-1 V-0	V-1	V-2 A-0	A-1 F-0	F-1
J	PUMP BRACKET ASSY		371889A01	1	1	1	1	1
1	WATER SUPPLY PIPE		371882G01	1	1	1	1	1
2	T2 SCREW	4X8	FT20408F0	9	9	9	9	9
3	RUBBER GASKET		413854-03	2	2	2	2	2
4	WATER VALVE	V19 4L/min	P01559-01	2	2	2	2	2
5	WATER VALVE BRACKET		371875G01	1	1	1	1	1
6	TRUSS HEAD SCREW	4X8 SUS	FST0408S0	4	4	4	4	4
7	SOLENOID VALVE	FDC-90-02-115	P00018-02	2	2	2	2	2
8	BRACKET - NSF VALVE		474226M01	1	1	1	1	1
9	TEE		371167R01	1	1	1	1	1
10	HOSE CLAMP ※Use either of the right	16.5mm SUS	427443-04	2	2	2	2	2
			P02909-04	2	2	2	2	2
11	HOSE CLAMP ※Use either of the right	18mm SUS	427443-05	6	6	6	6	6
			P02909-05	6	6	6	6	6
12	SPRAY TUBE		256969P01	1	1	1	1	1
13	PLUG		4A0176-01	2	2	2	2	2
14	CONNECTING PIPE		371162P02	1	1	1	1	1
15	SILICONE HOSE	Φ20XΦ 25(CLEAR)L=60	H12025060	1	1	1	1	1
16	SILICONE HOSE	Φ20XΦ 25(CLEAR)L=465	H12025465	1	1	1	1	1
17	HOSE CLAMP ※Use either of the right	25mm SUS	427443-03	4	4	4	4	4
			P02909-03	4	4	4	4	4
18	HOSE CLAMP ※Use either of the right	20mm SUS	427443-06	1	1	1	1	1
			P02909-06	1	1	1	1	1
19	BYPASS HOSE		371165R01	1	1	1	1	1
20	SILICONE HOSE	Φ15XΦ 19(CLEAR)L=340	H11519340	1	1	1	1	1
21	BYPASS INSULATION		371169Z01	1	1	1	1	1

HA

MODEL: KMD-410MAH		TITLE: C. WATER CIRCUIT ASSY						
INDEX NO.	DESCRIPTION	MATERIAL OR MODEL NUMBER	PART NUMBER	REQ'D NUMBER				
				U-1 V-0	V-1	V-2 A-0	A-1 F-0	F-1
22	WATER SUPPLY TUBE		256968P01	1	1	1	1	1
23	SPRAY GUIDE		252052P03	2	2	2	2	2
24	TANK		255326G02	1	1	1	1	1
25	PARTITION PLATE		371160P01	1	1	1	1	1
26	DRAIN CAP		371168G01	1	1	1	1	1
27	CUBE GUIDE		118904P01	1	1	1	1	1
28	DEFLECTOR (L)		255250P01	1	1	1	1	1
29	GASKET		371166R01	2	2	2	2	2
30	COLLAR		435269-01	4	4	4	4	4
31	T2 SCREW	4X16 SUS	FT20416M0	4	4	4	4	4
32	THUMBSCREW		415949G12	5	5	5	5	5
33	DEFLECTOR (R)		255249P01	1	1	1	1	1
34	FLOAT SWITCH	OLV-29Z-2P2	P00816-01	1	1	1	1	1
35	PUMP MOTOR	PV-211BHZ1	4A4259-01	1	1	1	1	1
36	INLET INSULATION		373079Z01	1	1	1	1	1

