



HOSHIZAKI

Parts List

Modular Crescent Cuber

Models

KMD-460MAJ

KMD-460MWJ



CONTENTS

Auxiliary Codes.....	3
Note About Ordering Parts	4
A. Main Assembly & Refrigeration Circuit	5
KMD-460MAJ	5
KMD-460MWJ.....	7
B. Water Circuit	9
C. Control Box Assembly	11
D. Accessories & Labels	13

Auxiliary Codes

KMD-460MAJ

H-0 September 2018

J-0 January 2019

KMD-460MWJ

H-0 September 2018

Auxiliary Code Breakdown

The auxiliary code is the first two characters in the serial number. The first character indicates the year. Years progress or regress in alphabetical order. The series runs from "A" through "V" and the letters "I" and "O" are skipped. The second character indicates significant part changes within a year. Base is "0" and this number advances for each change. In cases where there is a letter in parentheses, this designates the month. This is the last character in the serial number. The series runs from "(A)" through "(M)" and the letter "(I)" is skipped. This designation is only included when identifying a parts change within an auxiliary code.

Note About Ordering Parts

Most assemblies cannot be ordered as complete units; parts in the assemblies generally must be ordered separately.

A. Main Assembly & Refrigeration Circuit
KMD-460MAJ
H-0, J-0

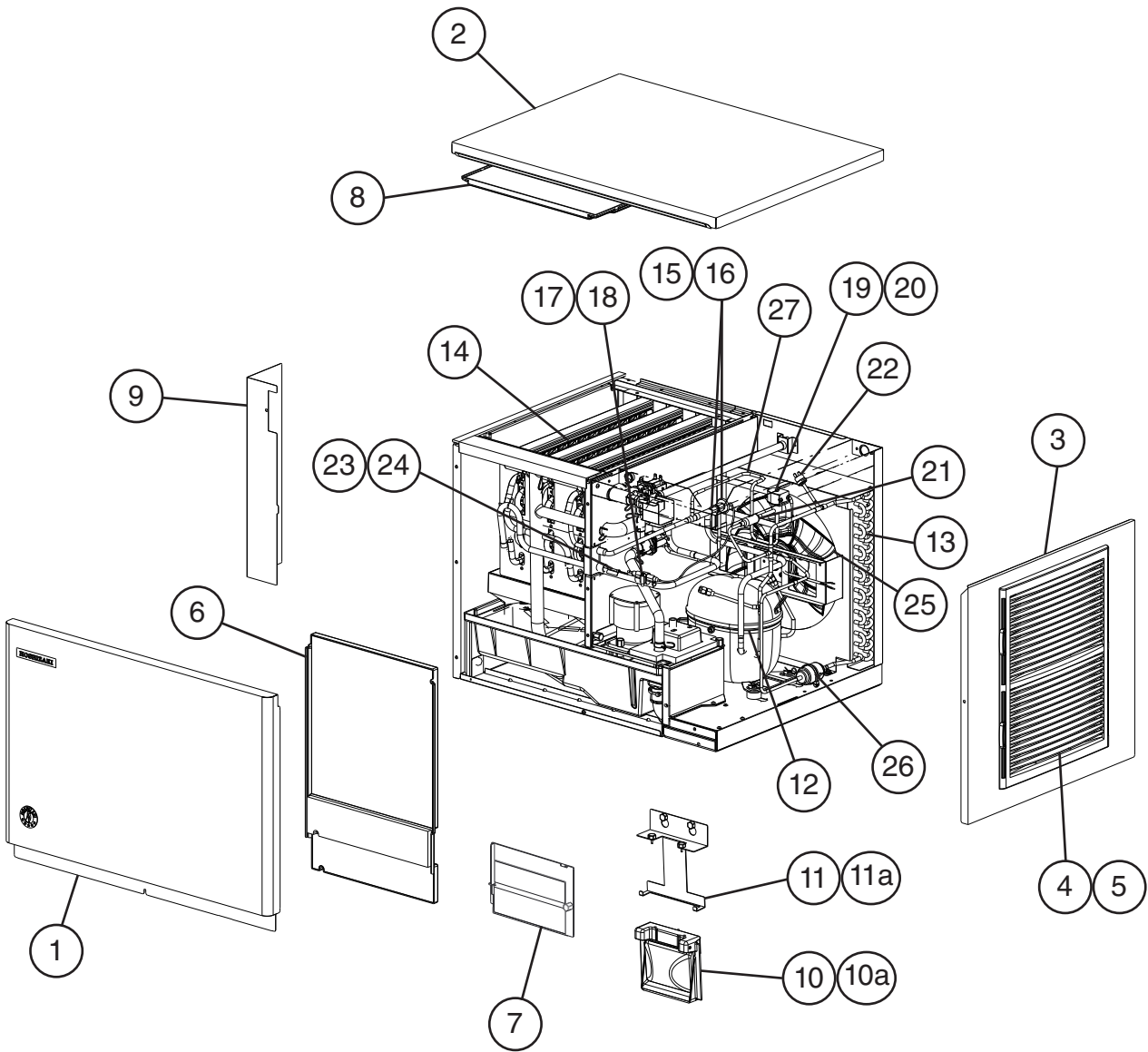

Title: A. Main Assembly & Refrigeration Circuit Model: KMD-460MAJ													
Index No.	Description	Material or Model Number	Part Number	Required Number									
				H-0	J-0								
Main Assembly													
1	Front Panel		3A9530G01	1									
2	Top Panel		3A4373G01	1									
3	Right Side Panel		2A4137G01	1									
4	Louver		1A1329-01	1									
5	Air Filter		2A4128G01	2									
6	Front Insulation A		3A5570G01	1									
7	Front Insulation B		3A4386G01	1									
8	Top Insulation		3A4394G01	1									
9	Control Box Cover		3A8289-01	1									
10	Bin Control		2A4393G02	1									
10a	Thumbscrew		415949G10	2									
11	Bin Control Bracket		3A8283-01	1									
11a	Thumbscrew		415949G10	2									
Refrigeration Circuit													
12	Compressor		4A4479-01	1									
13	Condenser		1A1363-01	1									
14	Evaporator		2A7811G01	1									
15	Thermostatic Expansion Valve		4A1414-01	1									
16	Thermostatic Expansion Valve Cover		3A0944-01	1									
17	Thermostatic Expansion Valve Holder		3A0107-01	1									
18	Clamp		443461-02	1									
19	Hot Gas Valve Body		4A3978-01	1									
20	Valve Coil		4A3277-01	1									
21	Strainer		441569-02	1									
22	High-Pressure Switch		463180-04	1									
23	Thermistor		429006-03	1									
24	Thermistor Holder		427430-01	1									
25	Fan Motor (includes blade)		P02596-01	1									
26	Drier		4A1113-01	1									
27	Heat Exchanger		4A6326G01	1									

A. Main Assembly & Refrigeration Circuit
KMD-460MWJ
H-0

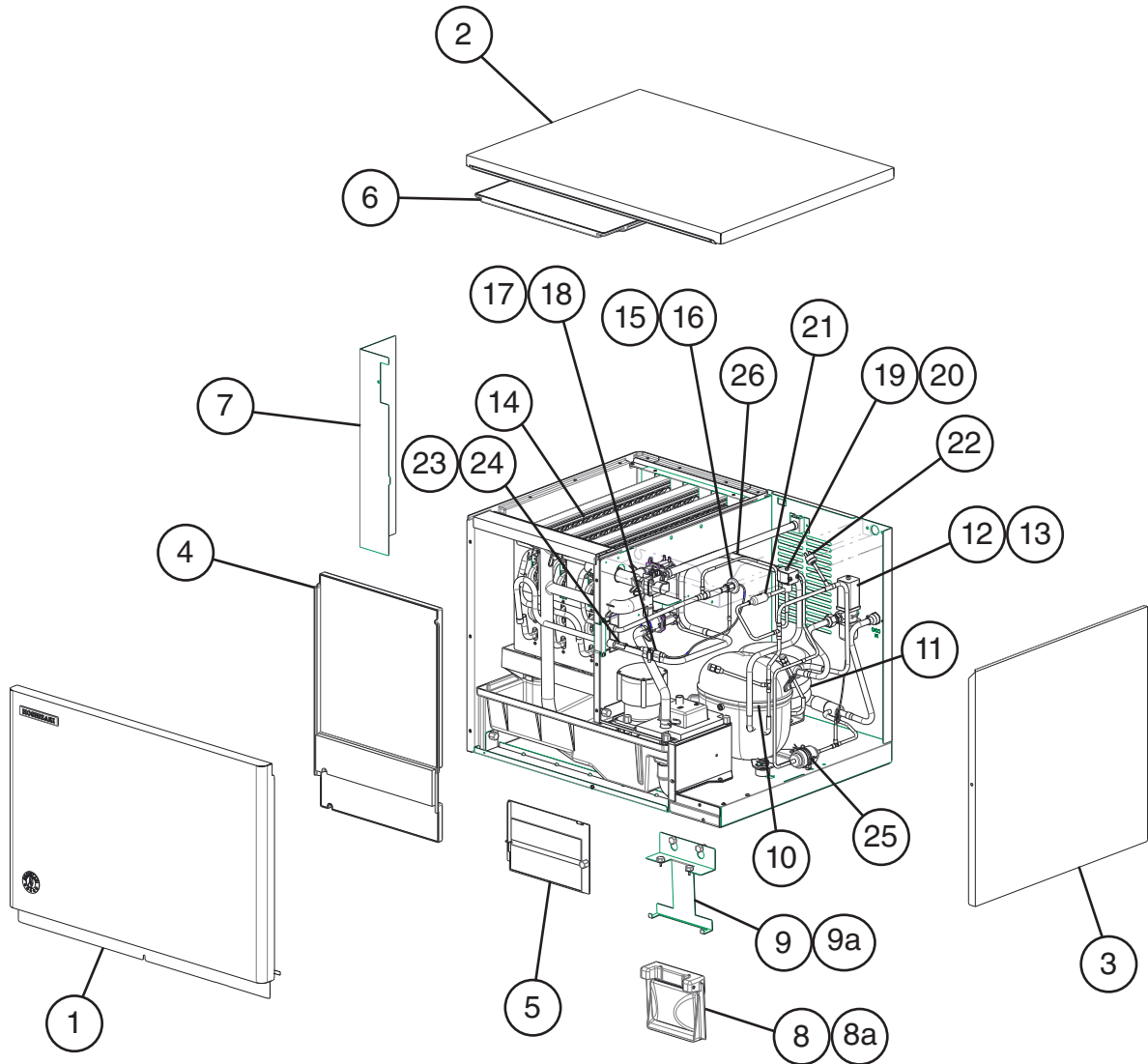

Title: A. Main Assembly & Refrigeration Circuit Model: KMD-460MWJ

Index No.	Description	Material or Model Number	Part Number	Required Number									
				H-0									
Main Assembly													
1	Front Panel		3A9530G01	1									
2	Top Panel		3A4373G01	1									
3	Right Side Panel		2A4173G01	1									
4	Front Insulation A		3A5570G01	1									
5	Front Insulation B		3A4386G01	1									
6	Top Insulation		3A4394G01	1									
7	Control Box Cover		3A8289-01	1									
8	Bin Control		2A4393G02	1									
8a	Thumbscrew		415949G10	2									
9	Bin Control Bracket		3A8283-01	1									
9a	Thumbscrew		415949G10	2									
Refrigeration Circuit													
10	Compressor		4A4479-01	1									
11	Condenser - Water Cooled		3A8514-01	1									
12	Water Regulator		4A0911-06	1									
13	Male Connector		4A1087-01	1									
14	Evaporator		2A7811G01	1									
15	Thermostatic Expansion Valve		4A1414-01	1									
16	Thermostatic Expansion Valve Cover		3A0944-01	1									
17	Thermostatic Expansion Valve Holder		3A0107-01	1									
18	Clamp		443461-02	1									
19	Hot Gas Valve Body		4A3978-01	1									
20	Valve Coil		4A3277-01	1									
21	Strainer		441569-02	1									
22	High-Pressure Switch		463180-05	1									
23	Thermistor		429006-03	1									
24	Thermistor Holder		427430-01	1									
25	Drier		4A1113-01	1									
26	Heat Exchanger		1A5318G01	1									

B. Water Circuit
KMD-460MAJ, KMD-460MWJ
H-0, J-0

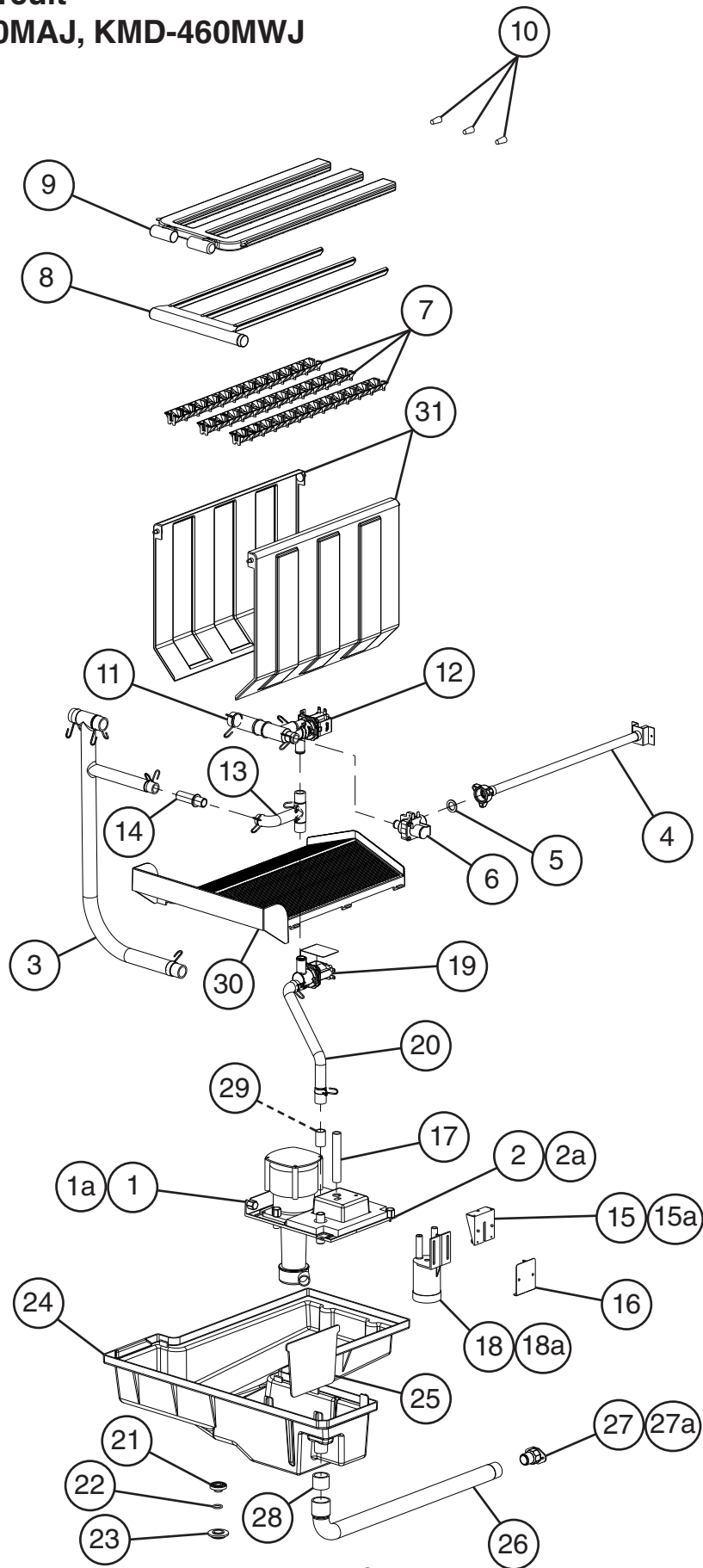

Title: B. Water Circuit Model: KMD-460MAJ, KMD-460MWJ												
Index No.	Description	Material or Model Number	Part Number	Required Number								
				H-0	J-0							
1	Pump Motor		4A4259-01	1	1							
1a	Thumbscrew		415949G12	1	1							
2	Pump Motor Bracket		1A1341G01	1	1							
2a	Thumbscrew		415949G12	2	2							
3	Pump Hose		4A5685-01	1	1							
4	Water Supply Pipe		4A5089L01	1	1							
5	Rubber Gasket		413854-03	1	1							
6	Inlet Water Valve		3U0111-03	1	1							
7	Spray Guide		2A4282-04	3	3							
8	Water Supply Tube		2A4132-01	1	1							
9	Spray Tube		2A4133-01	1	1							
10	Plug		4A0176-01	3	3							
11	Water Valve Hose (tee)		3A4366-01	1	1							
12	Water Valve (Cleaning)		4A5745-01	1	1							
13	Bypass Hose (tee)		4A5687-01	1	1							
14	Evaporator Pipe		4A3765-02	1	1							
15	Float Switch Bracket		327757-02	1	1							
15a	T2 Screw	4x12	7P32-0412	1	1							
16	Float Switch Stop		4A6399-01	1	1							
17	Vinyl Hose	40mm	7716-1216	1	1							
18	Float Switch		4A3624-01	1	1							
18a	T2 Screw		7P32-0412	2	2							
19	Water Valve (Drain)		4A5745-03	1	1							
20	Drain Hose		4A5688-01	1	1							
21	Drain Plug		309246-01	1	1							
22	O-Ring		7611-P015	1	1							
23	Drain Nut		415619-01	1	1							
24	Tank		3A8316G01	1	1							
25	Tank Separator		4A4239-01	1	1							
26	Tank Drain Hose		4A5684-01	1	1							
27	Drain Fitting		4A5528-01	1	1							
27a	T2 Screw	4x8	7P32-0408	2	2							
28	Vinyl Hose	25mm	4A0658L01	1	1							
29	Vinyl Hose		7716-1519	1	1							
30	Cube Guide		1A1336-01	1	1							
31	Splash Curtain		2A7452G01	2	2							
Hose Clamps												
	Hose Clamp	25 mm	427443-03	4	4							
	Hose Clamp	18 mm	427443-05	2	2							
	Hose Clamp	20 mm	427443-06	6	6							

C. Control Box Assembly
KMD-460MAJ, KMD-460MWJ
H-0, J-0

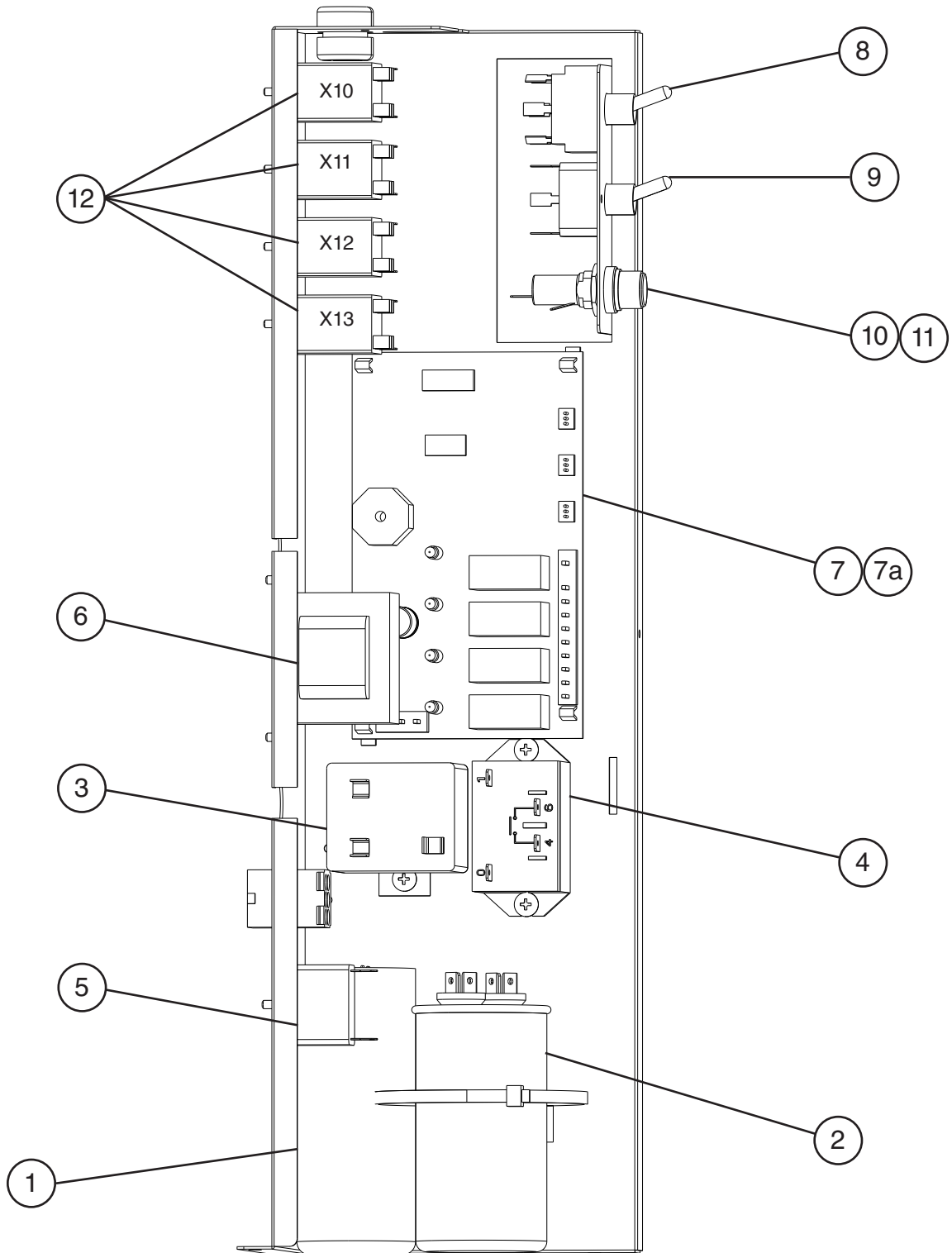

Title: C. Control Box Assembly Model: KMD-460MAJ, KMD-460MWJ												
Index No.	Description	Material or Model Number	Part Number	Required Number								
				H-0 J-0								
1	Start Capacitor	243-292MFD, 165VAC	3A0076-20	1								
2	Run Capacitor	30MFD, 370VAC	3A2005-12	1								
3	Start Relay		4A1107-11	1								
4	Compressor Relay		4A3140-01	1								
5	Pump Motor Capacitor	2.5MFD, 250VAC	4A2128-05	1								
6	Control Transformer		3A0172-01	1								
7	Control Board		2A7664-04	1								
7a	Control Board Support		4A0336-03	4								
8	Toggle Switch (Control)		443119-01	1								
9	Toggle Switch (Service)		4A0985-01	1								
10	Fuse Holder		4A5443-01	1								
11	Fuse	AGC-10A, 250VAC	4A0893-07	1								
12	Relay (X10 - Pump Motor Relay X11 - Control Relay X12 - Pump Motor Relay X13 - Service Relay)		406132-07	4								

D. Accessories & Labels
KMD-460MAJ, KMD-460MWJ
H-0, J-0

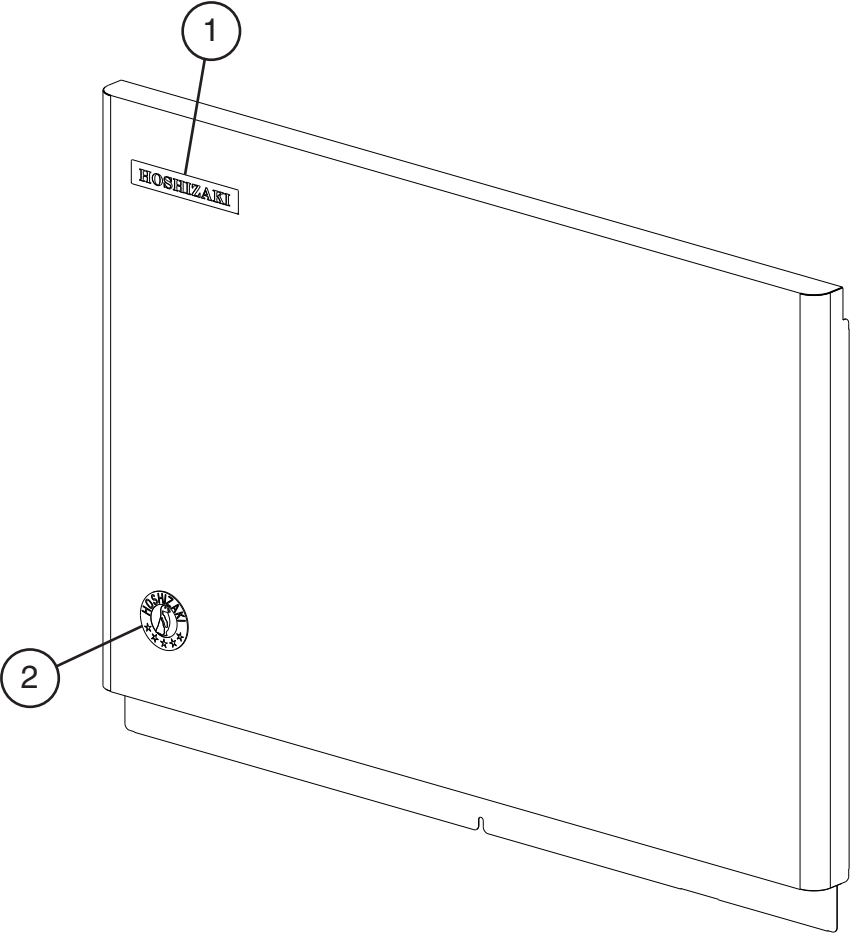

Title: D. Accessories & Labels Model: KMD-460MAJ, KMD-460MWJ											
Index No.	Description	Material or Model Number	Part Number	Required Number							
				H-0	J-0						
1	Emblem		4A0560-01	1							
2	Penguin Label		475552L02	1							
3	Universal Brace		4A0363-01	2							
3a	Hex Bolt	5x12, SS	7B02-0512	2							