



HOSHIZAKI

Parts List

Modular Crescent Cuber

Models

KML-250MAH

KML-250MWH



hoshizakiamerica.com

Number: 71192
Issued: 9-18-2001
Revised: 7-17-2020

CONTENTS

Auxiliary Codes.....	3
Note About Ordering Parts	3
A. Ice Cuber Assembly	4
KML-250MAH.....	4
KML-250MWH.....	7
B. Water Circuit.....	10
D. Accessories & Labels	13

Auxiliary Codes

KML-250MAH			KML-250MWH		
	L-0	May 2001		L-1	October 2001
	M-0	January 2002		M-0	December 2001
	M-1	April 2002		M-1	March 2002
	M-2	July 2002		M-2	July 2002
	N-0	December 2002		N-0	January 2003
	N-1	March 2003		N-1	March 2003
	P-0	December 2003		P-0	December 2003
	P-1	June 2004		Q-0	January 2005
	Q-0	December 2004		R-0	January 2006
	R-0	December 2005		S-1	January 2007
	S-1	January 2007		S-2	December 2007
	S-2	December 2007		T-0	January 2008
	T-0	May 2008		U-0	January 2009
	U-0	January 2009		U-1	July 2009
	U-1	July 2009		V-0	February 2010
	V-0	January 2010		A-0	January 2011
	V-1	February 2010		A-1	October 2011
	A-0	January 2011		B-0	January 2012
	A-1	September 2011		B-1	November 2012
	B-0	January 2012		C-0	January 2013
	B-1	November 2012		C-1	May 2013
	C-0	January 2013		D-0	January 2014
	D-0	January 2014		E-0	February 2015
	E-0	January 2015		F-0	January 2016
	F-0	January 2016		G-0	January 2017
	G-0	January 2017			

Auxiliary Code Breakdown

The auxiliary code is the first two characters in the serial number. The first character indicates the year. Years progress or regress in alphabetical order. The series runs from "A" through "V" and the letters "I" and "O" are skipped. The second character indicates significant part changes within a year. Base is "0" and this number advances for each change. In cases where there is a letter in parentheses, this designates the month. This is the last character in the serial number. The series runs from "(A)" through "(M)" and the letter "(I)" is skipped. This designation is only included when identifying a parts change within an auxiliary code.

Note About Ordering Parts

Most assemblies cannot be ordered as complete units; parts in the assemblies generally must be ordered separately.

A. Ice Cuber Assembly
KML-250MAH
 L-0 to G-0

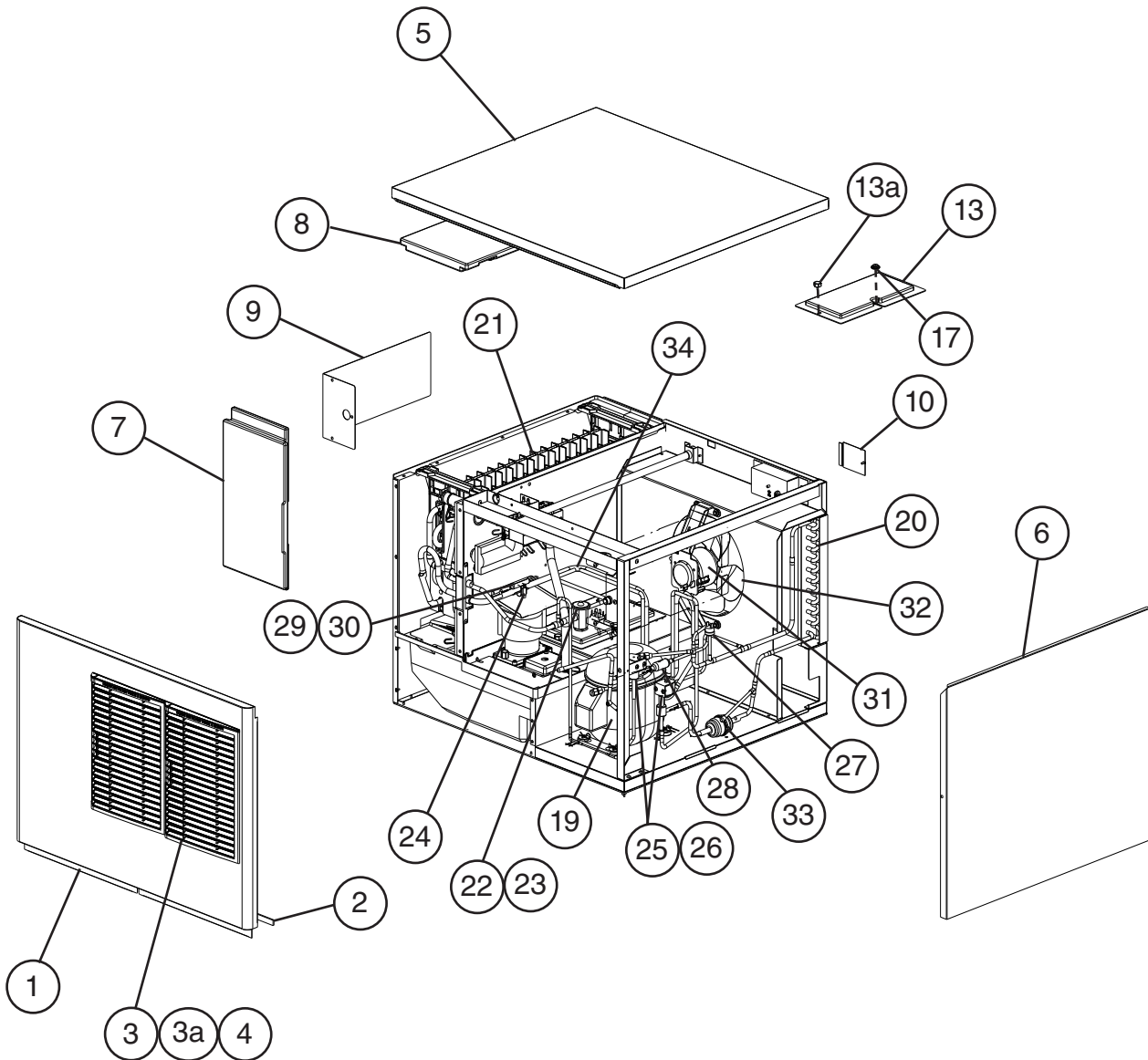

For Thermostat, see
 "C. Control Box Assembly"

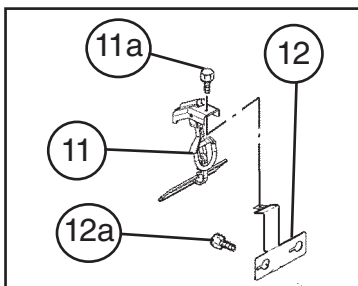

L-0 to M-1

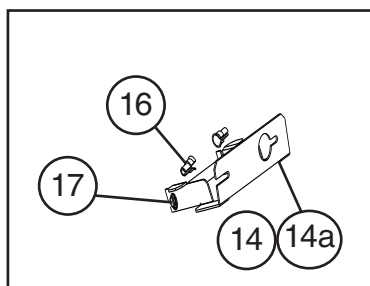

M-2 to S-1

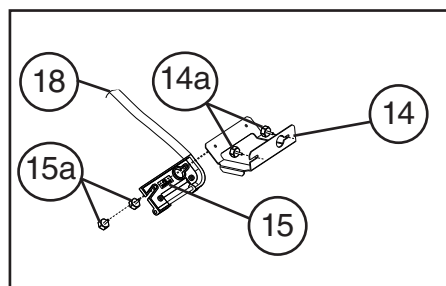

S-2 and Later

Title: A. Ice Cuber Assembly Model: KML-250MAH													
Index No.	Description	Material or Model Number	Part Number	Required Number									
				L-0 to M-1	M-2 to S-1	S-2 to U-0	U-1	V-0 to G-0					
Ice Cuber Assembly													
1	Front Panel		3A1859A01	1	1	1	1	1					
2	Gasket		4A0808L02	1	1	1	1	1					
3	Louver		1A0548-01	2	2	2	2	2					
3a	Push Retainer		4A2414-01	6	6	6	6	6					
4	Air Filter		2A2063G01	2	2	2	2	2					
5	Top Panel		3A1862A01	1	1	1	1	1					
6	Right Side Panel		2A2111G01	1	1	1	1	1					
7	Front Insulation		2A0664G01	1	1	1	1	1					
8	Top Insulation		215730G01	1	1	1	1	1					
9	Control Box Cover		3A1828-01	1	-								
			3A2371-01		1	1	1	1					
10	Junction Box Cover		433410-01	1	1	1	1	1					
11	Mechanical Bin Control		4A2430-01	1	-								
11a	Thumbscrew		4H3270G01	1	-								
12	Bracket (L)		3A1433-01	1	-								
12a	Thumbscrew		415949G09	2	-								
13	Bin Control Cover		3A0664G01	1	1	1	1						
13a	Thumbscrew		415949G04	2	2	-							
			415949G08			2	2	-					
			415949G10						2				
14	Bin Control Bulb Extension Bracket		4A1722-01		1	-							
			4A4358-01			1	1	1					
14a	Thumbscrew		415949G09		2	-							
			415949G10			2	-						
			415949G08				2	2					
15	Bin Control Bulb Holder		3A3903-01			1	1	1					
15a	Thumbscrew		415949G11			2	-						
			415949G10				2	2					
16	Spacer		443545-01		2	-							
17	Capillary Ring		425307-02		2	1	1	1					
18	Silicone Hose	L=310 mm	773013812			1	1	1					
Refrigeration Circuit													
19	Compressor		4A2456-01	1	1	1	1	1					
20	Condenser		2A0779-01	1	1	1	1	1					
21	Evaporator		2A0717G01	1	1	1	1	1					
22	Thermostatic Expansion Valve		4A1870-01	1	1	1	1	1					
23	Thermostatic Expansion Valve Cover		4A1168-01	1	1	1	1	1					
24	Thermostatic Expansion Valve Holder		3A0112-01	1	1	1	1	1					
25	Hot Gas Valve Body		4A3978-01	1	1	1	1	1					
26	Vale Coil		4A3277-01	1	1	1	1	1					
27	High-Pressure Switch		433441-07	1	1	1	1	-					
			463180-04					1					

Title: A. Ice Cuber Assembly Model: KML-250MAH

Index No.	Description	Material or Model Number	Part Number	Required Number								
				L-0 to M-1	M-2 to S-1	S-2 to U-0	U-1	V-0 to G-0				
28	Strainer		4A0397-01	1	1	1	1	-				
			441569-02					1				
29	Thermistor		429006-03	1	1	1	1	1				
30	Thermistor Holder		427430-01	1	1	1	1	1				
31	Fan Motor		4A1179-01	1	1	1	1	1				
32	Fan Blade		3A0438-01	1	1	1	1	1				
33	Drier		4A2666-01	1	1	1	1	1				
34	Heat Exchanger		2A2139G01	1	1	1	1	1				

A. Ice Cuber Assembly
KML-250MWH
 L-1 to G-0

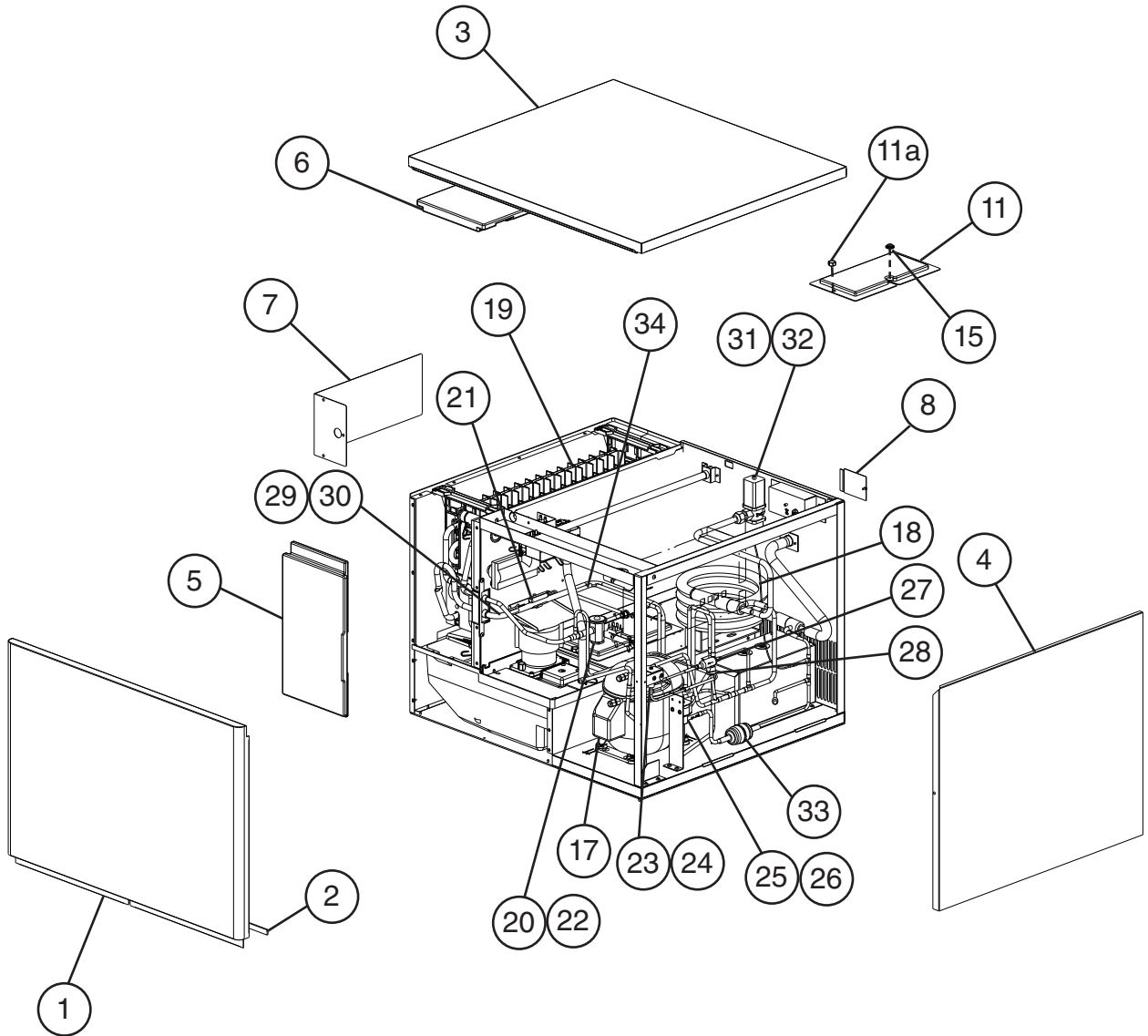

For Thermostat, see
 "C. Control Box Assembly"

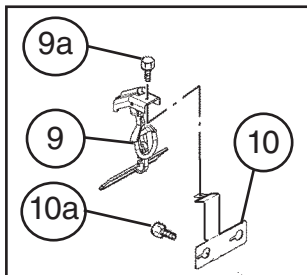

L-1 to M-1

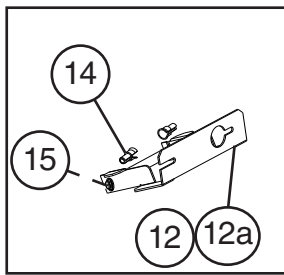

M-2 to S-1

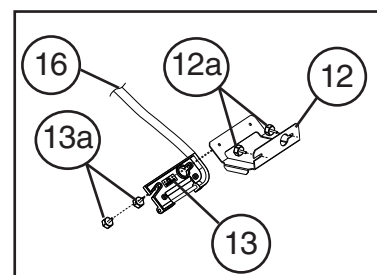

S-2 and Later

Title: A. Ice Cuber Assembly Model: KML-250MWH												
Index No.	Description	Material or Model Number	Part Number	Required Number								
				L-1 to M-1	M-2 to S-1	S-2 to U-0	U-1	V-0 to B-1	C-1 to G-0			
Ice Cuber Assembly												
1	Front Panel		3A1859A02	1	1	1	1	1	1	1		
2	Gasket		4A0808L02	1	1	1	1	1	1			
3	Top Panel		3A1862A01	1	1	1	1	1	1			
4	Right Side Panel		2A2111G01	1	1	1	1	1	1			
5	Front Insulation		2A0664G01	1	1	1	1	1	1			
6	Top Insulation		215730G01	1	1	1	1	1	1			
7	Control Box Cover		3A1828-01	1	-							
			3A2371-01		1	1	1	1	1			
8	Junction Box Cover		433410-01	1	1	1	1	1	1			
9	Mechanical Bin Control		4A2430-01	1	-							
9a	Thumbscrew		4H3270G01	1	-							
10	Bracket (L)		3A1433-01	1	-							
10a	Thumbscrew		415949G09	2	-							
11	Bin Control Cover		3A0664G01	1	1	1	1	1	1			
11a	Thumbscrew		415949G04	2	2	-						
			415949G08			2	2	-				
			415949G10					2	2			
12	Bin Control Bulb Extension Bracket		4A1722-01		1	-						
			4A4358-01			1	1	1	1			
12a	Thumbscrew		415949G09	2	2	-						
			415949G10			2	-					
			415949G08				2	2	2			
13	Bin Control Bulb Holder		3A3903-01			1	1	1	1			
13a	Thumbscrew		415949G11			2	-					
			415949G10				2	2	2			
14	Spacer		443545-01		2	-						
15	Capillary Ring		425307-02		2	1	1	1	1			
16	Silicone Hose		773013812			1	1	1	1			
Refrigeration Circuit												
17	Compressor		4A2456-01	1	1	1	1	1	1			
18	Condenser		2A2359G01	1	1	1	1	1	-			
			3A7321-01						1			
19	Evaporator		2A0717G01	1	1	1	1	1	1			
20	Thermostatic Expansion Valve		4A1870-01	1	1	1	1	1	1			
21	Thermostatic Expansion Valve Holder		3A0112-01	1	1	1	1	1	1			
22	Thermostatic Expansion Valve Cover		4A1168-01	1	1	1	1	1	1			
23	Hot Gas Valve Body		3U0151-01	1	1	1	1	1	1			
24	Valve Coil		3U0151F01	1	1	1	1	1	1			
25	Liquid Line Valve Body		4A3276-01	1	1	1	1	1	1			
26	Valve Coil		4A3277-01	1	1	1	1	1	1			
27	Strainer		4A0397-01	1	1	1	1	1	-			
			441569-02						1			

Title: A. Ice Cuber Assembly Model: KML-250MWH												
Index No.	Description	Material or Model Number	Part Number	Required Number								
				L-1 to M-1	M-2 to S-1	S-2 to U-0	U-1	V-0 to B-1	C-1 to G-0			
28	Hight-Pressure Switch		433441-05	1	1	1	1	1	-			
			463180-05						1			
29	Thermistor		429006-03	1	1	1	1	1	1			
30	Thermistor Holder		427430-01	1	1	1	1	1	1			
31	Water Regulating Valve		4A0911-03	1	-							
			4A0911-06		1	1	1	1	1			
32	Male Connector		4A1087-01	1	1	1	1	1	1			
33	Drier		4A2666-01	1	1	1	1	1	1			
34	Heat Exchanger		2A2139G01	1	1	1	1	1	1			

B. Water Circuit
KML-250MAH, KML-250MWH
 L-0 to G-0

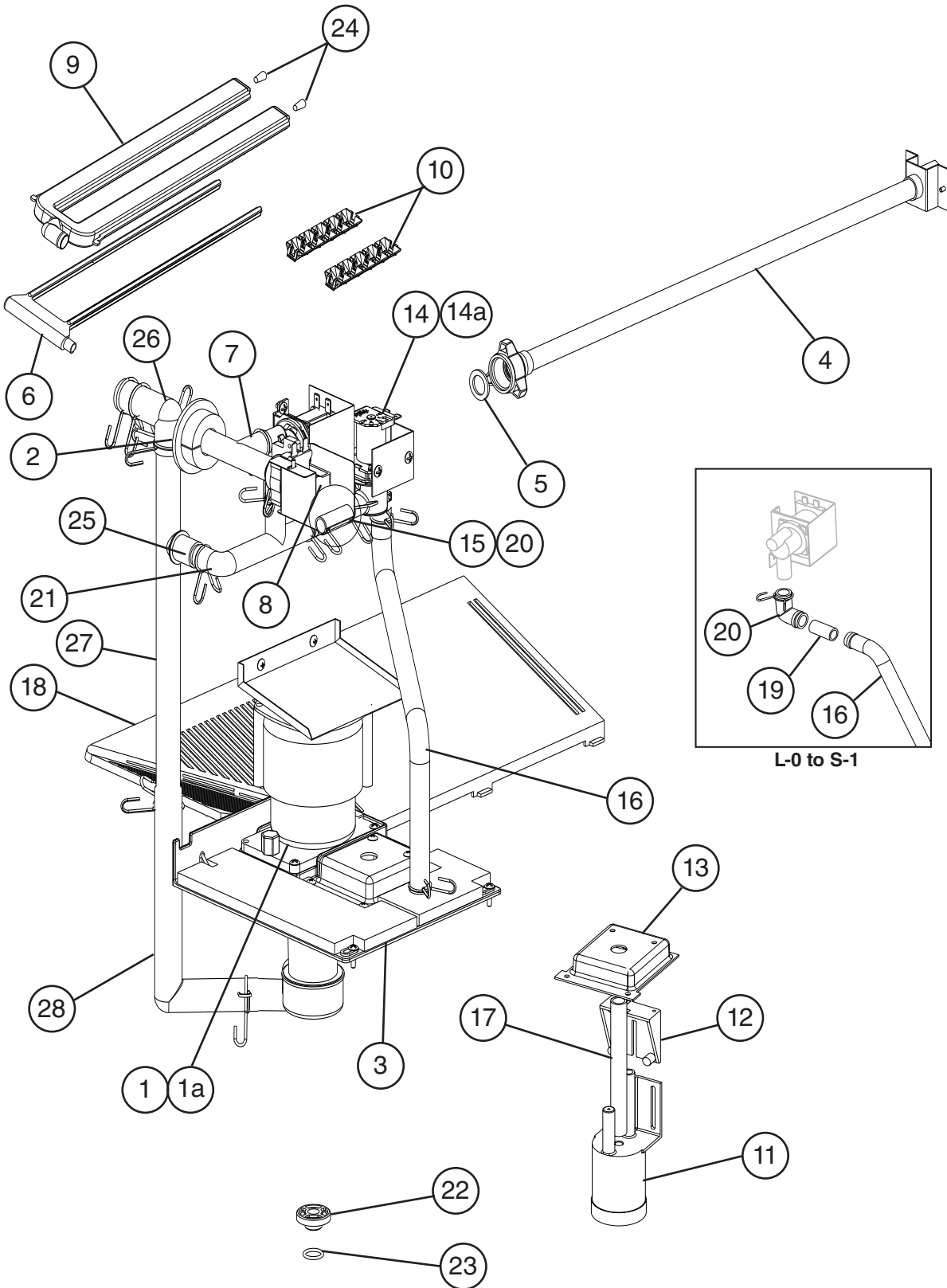

Title: B. Water Circuit Model: KML-250MAH, KML-250MWH											
Index No.	Description	Material or Model Number	Part Number	Required Number							
				L-0 to R-0	S-1	S-2 to U-0	U-1 to G-0				
1	Pump Motor		2A0749-01	1	1	-					
			2A2861-01			1	-				
			4A4259-01				1				
1a	Truss Head Screw	4x16, SS	7C32-0416	4	4	4	-				
	Thumbscrew		415949G11				1				
2	Flange		439267-01	1	1	1	1				
3	Pump Motor Bracket		2A4920G01				1				
4	Water Supply Pipe		4A0768G04	1	1	1	1				
5	Rubber Gasket		413854-03	1	1	1	1				
6	Water Supply Tube		2A0079-01	1	1	1	1				
7	Water Supply Tee		4A1006-01	1	1	1	1				
8	Inlet Water Valve		3U0111-04	1	1	1	1				
9	Spray Tube		1A0260-02	1	1	1	1				
10	Spray Guide		208586-01	6	6	6	6				
11	Float Switch		4A0886-01	1	-						
			4A3624-01		1	1	1				
12	Float Switch Bracket		327757-01	1	1	1	1				
13	Float Switch Cover		3A0665-01	1	1	1	1				
14	Water Valve (Wash & Drain)		439322-01	2	2	-					
			4A3722-01			2	2				
15	Vinyl Hose	L=55 mm	7716-1519			1	1				
16	Vinyl Hose	L=275 mm	7716-1519	1	1	-					
		L=320 mm				1	1				
17	Vinyl Hose	L=150 mm	7716-1216	1	1	1	1				
18	Cube Guide		2A0660-01	1	1	1	1				
19	Joint Pipe		439329-01	1	1	1	1				
20	Elbow		433467-01	1	1	-					
21	Bypass Hose		4A1005-01	1	1	1	1				
22	Drain Plug		309246-01	1	1	1	1				
23	O-Ring		7611-P015	1	1	1	1				
24	Plug		4A0176-01	2	2	2	2				
25	Rubber Ring		4A1004-01	1	1	1	1				
26	Elbow		4A0393-01	1	1	1	1				
27	Connecting Pipe		3A1335-01	1	1	1	1				
28	Pump Hose		325867-01	1	1	1	1				
Hose Clamp											
	Hose Clamp	25 mm	427443-03	5	5	5	5				
	Hose Clamp	18 mm	427443-05	8	8	8	8				
	Hose Clamp	20 mm	427443-06	2	2	2	2				

C. Control Box Assembly
KML-250MAH, KML-250MWH
 L-0 to G-0

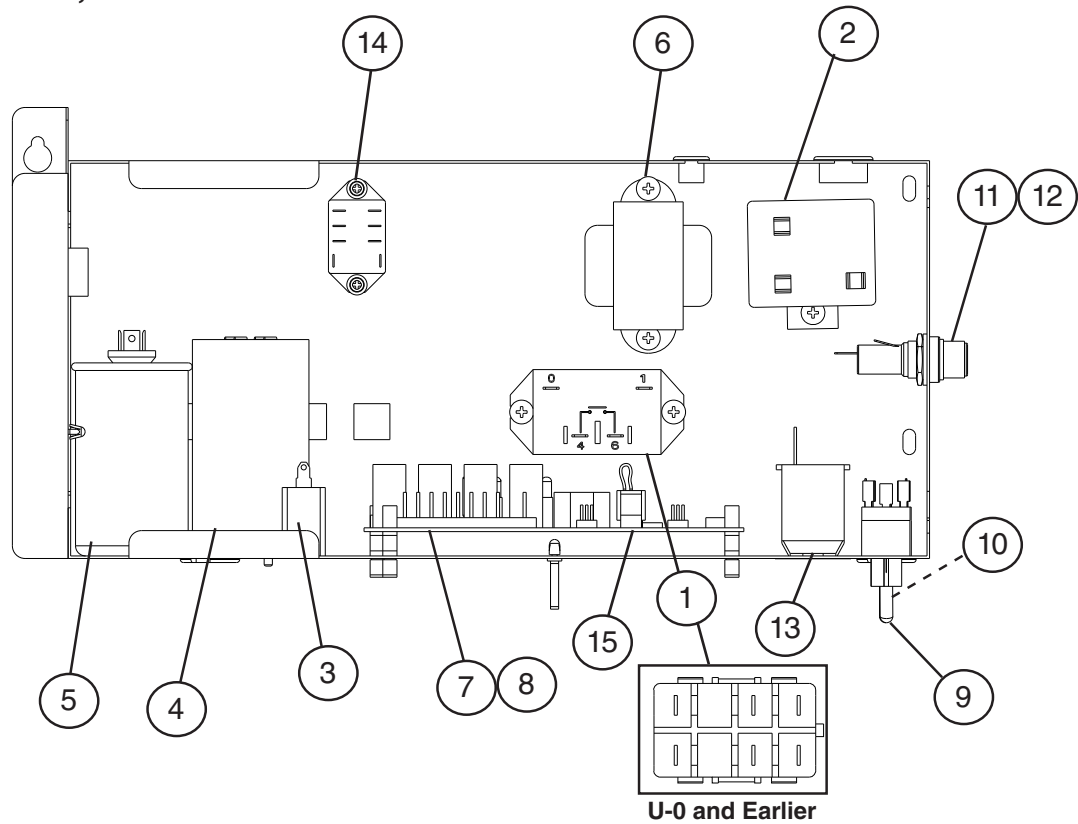

Title: C. Control Box Assembly		Model: KML-250MAH, KML-250MWH		Required Number							
Index No.	Description	Material or Model Number	Part Number	L-0 to M-1	M-2 to U-0	U-1 to B-0	B-1 to G-0				
				1	Magnetic Contactor		428393-01	1	1	1	-
	Compressor Relay		4A3140-01				1				
2	Start Relay		4A1107-14	1	1	1	1				
3	Pump Motor Capacitor	2.5MFD, 250 VAC	4A2128-05			1	1				
4	Start Capacitor	72-86MFD, 330 VAC	3A1414-01	1	1	1	1				
5	Run Capacitor	20MFD, 440 VAC	3A2005-01	1	1	1	1				
6	Control Transformer		3A0172-01	1	1	1	1				
7	"E" Control Board		2A1410-01	1	1	1	-				
	"G" Control Board		2A3792-01				1				
8	Control Board Support		4A0336-03	4	4	4	4				
9	Control Switch		443119-01	1	1	1	1				
10	Service Switch		4A0985-01	1	1	1	1				
11	Fuse Holder		4A5443-01	1	1	1	1				
12	Fuse	AGC-10A, 250VAC	4A0893-07		2	2	1				
13	Bin Control Thermostat		4A2879-01		1	1	1				
14	Drain Relay		406132-07	1	1	1	1				
15	K4 Jumper		4A4883G01				1				

D. Accessories & Labels
KML-250MAH, KML-250MWH
 L-0 to G-0

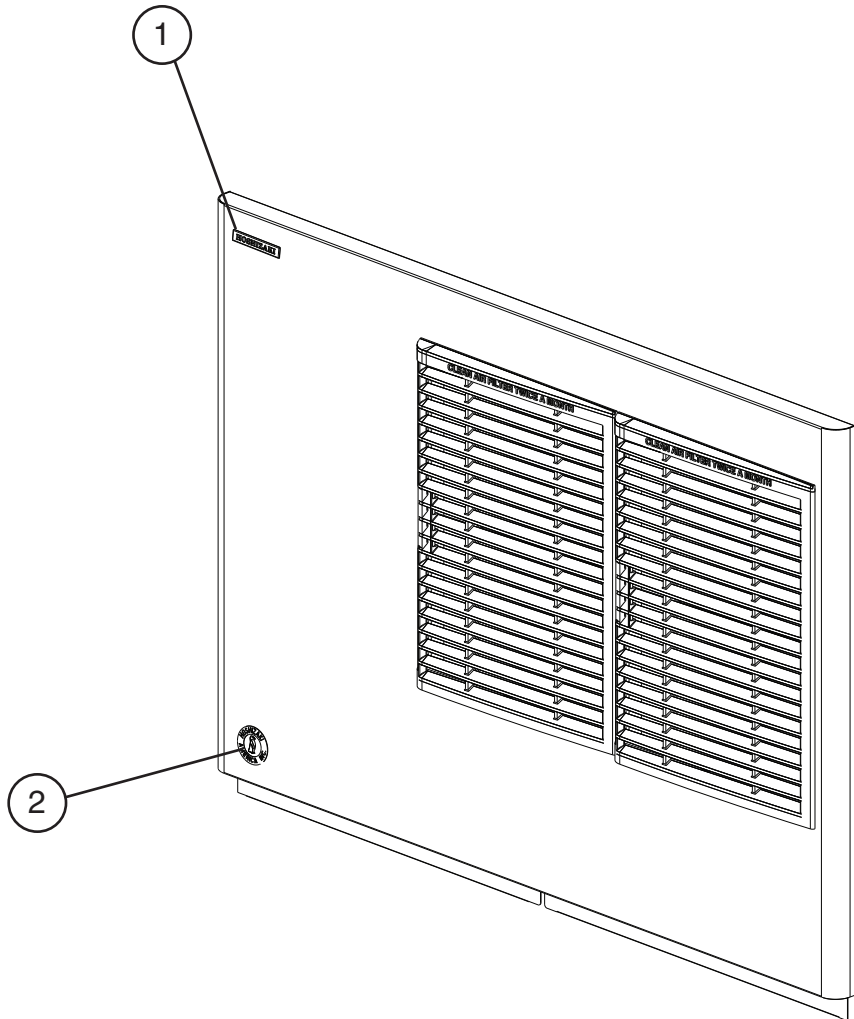

Title: D. Accessories & Labels Model: KML-250MAH, KML-250MWH					Required Number								
Index No.	Description	Material or Model Number	Part Number	L-0 to G-0									
1	Hoshizaki Emblem Label		4A0560-01	1									
2	Penguin Label		4A0526-01	1									
3	Universal Brace		4A0363-01	2									
3a	Hex Head Bolt	5x12, SS	7B02-051	2									